

HECKLER & KOCH MODEL 91 & 93

SPECIFICATIONS:

H & K 91	308CAL.
H & K 93	223 CAL.
CAPACITY (H & K 91)	20 ROUND MAGAZINE
(H & K 93)	20,40 ROUND MAGAZINE
TYPE OF FIRE	SELECTIVE - SEMI AND FULL AUTOMATIC

REMARKS: *ORIGINALLY MANUFACTURED AS CIVILIAN SEMI-AUTOMATIC VERSION OF G3 AUTOMATIC RIFLES MADE IN WEST GERMANY. VARIETY OF ACCESSORIES SUCH AS TELESCOPING STOCK, BIPOD, SCOPE MOUNTS, ETC., AVAILABLE.*

LOADING, UNLOADING, AND FIRING:

Loading, unloading, and firing the converted model are accomplished in the same way as on the semi automatic system. The only different factor is that the weapon now has the provision for full automatic firing.

NOTE: THE ORIGINAL FACTORY SAFETY LEVER IS NOW REPLACED WITH AN IMPROVISED SAFETY-SELECTOR TYPE LEVER THAT HAS A CLEARANCE NOTCH TO BYPASS THE INDEX RAIL BLOCK OF THE GRIP FRAME. THIS WILL ENABLE THE NEW SELECTOR LEVER TO BE ROTATED FULLY DOWNWARD AS WITH ITS MILITARY COUNTERPART SELECTOR SETTING.

THE NEW IMPROVISED SELECTOR LEVER AND ITS FUNCTION:

The selector lever has a three position setting: SAFE, SEMI, and FULL AUTOMATIC. With the selector set on its upward most

position, the trigger is locked and cannot be pressed.

SEMI AUTOMATIC FUNCTIONING: Set the selector to the middle notch to make the weapon function in the semi-automatic mode. The trigger must be released after each shot for successive shots, until the magazine is empty.

FULL AUTOMATIC FUNCTIONING: Set the selector to its lowest (third) notch setting to function on full automatic. In this position the deep notch of the selector pin permits the trigger to overtravel, thereby preventing the sear from catching the hammer notch during bolt recoil. The hammer will then move with the bolt during its rearward and forward recoil, firing the cartridge in the chamber as soon as the bolt closes fully. At this time the locking rollers are fully in. The firing pin will not hit the cartridge primer if the bolt is not fully locked via the rollers. This operation is continued until the trigger is released or the magazine empty.

THE CONVERSION TECHNIQUE:

The original models are manufactured as semi-automatic rifles only. Necessary modifications have been undertaken by the manufacturer to ensure that the commercial variants cannot be converted to full automatic, even by substituting its military trigger mechanism. The bolt on the military models has a tripping shoulder to operate the safety sear mechanically during bolt closing. On the civilian model this shoulder has been fully machined, and therefore will not function even if the military trigger mechanism is substituted for the commercial trigger housing and frame.

The grip frame with the stock has only two settings on its index rail: SAFE and FIRE. Further downward movement is blocked by rail indentation.

The trigger housing body that contains the trigger mechanism has a built in trigger block in the form of a sturdy pin brazed to the right side of the frame. This is another factor that prevents the trigger from overtraveling for full automatic functioning. This pin can be removed by simply drilling through it or filing it with a needle file from the inside. The entire trigger mechanism must first be removed before removing the block pin. Once this pin is removed, the trigger can overtravel far enough to not engage with the hammer notch when fully pressed. This is the full automatic setting.

THE REPLACEMENT SELECTOR LEVER DETAIL:

High quality steel plate 1/2 inch thick is used. The style and pattern of the original lever can be copied. It will contain an index ball with a strong spring for positive indexing. (Refer to diagram for a selector lever sample construction.) The lever should have a clearance notch to bypass the index rail block when set to full automatic.

The selector pin should be perfectly dimensioned from the original lever pin to ensure positive fit and operation.

THE GRIP STOCK FRAME DETAIL:

Since the grip frame has been fitted with a new selector lever, new index holes for types of fire setting must be drilled, preferably between the original index rail and selector lever pin hole.

To calculate the new index hole, install the new selector lever (completely assembled with its index ball and spring in place and appropriate pin notches) to the grip housing with the trigger mechanism unit inside. Set the selector lever on the safe position as with the original safety lever position. Remove the selector lever and mark the end of the index ball travel. Rotate the selector to the semi automatic setting. Cock the hammer by hand and press the trigger. The hammer should be released when the trigger is pressed in this position. Retain pressure on the trigger and re-cock the hammer. The hammer should engage with the sear while the trigger is pressed. Release the trigger and press again. The hammer should be released once the trigger is pressed. Again mark the end of the index ball travel with a scribe for the semi-automatic notch.

After the semi-automatic notch has been calculated, press the selector down while pressing the trigger until the trigger reaches the deep notch of the selector pin. Cock the hammer while pressing the trigger to see if it still engages with the sear. If it does, deepen the selector pin notch until the sear has enough clearance not to engage with the hammer.

Mark the index ball end travel for the full automatic index notch.

Remove the selector and drill a 1/16 inch hole at the marked index location; DO NOT DRILL THROUGH.

NOTE: TO A VOID A MISTAKE, REPEAT THE PROCEDURE OF CALCULATING THE PRECISE INDEX HOLES UNTIL FULLY SATISFIED. THIS IS THE TRICKY PART OF THE JOB.

NOTES FOR HECKLER & KOCH 91 & 93 AUTOMATIC CONVERSION

Both the H & K 91 and 93 are civilian models designed primarily for semi-automatic functioning, utilizing different bolts than the military models. In the civilian version, the disconnecting shoulder of the bolt is machined to prevent operation of the automatic sear release lever. The trigger housing is also modified to conform with the semi automatic trigger mechanism. The grip frame containing the trigger housing unit is also different, most notably in the safety indexing rail for fire setting. In the military model, there are three index notches. The third notch is for the full automatic mode of fire. The latest military model from H & K features four notches, one of which is the three round burst setting that permits only three shots to be fired when the trigger is held back.

Both the H & K 91 and 93 have only two index settings. The settings are "SAFE" and "FIRE," and function solely in the semi-automatic mode. The safety index rail has a protruding indentation to block the safety from moving further downward.

The mere substitution of the selective military trigger mechanism will not convert the weapon to selective fire functioning, since the disconnecting shoulder of the bolt has been machined. It is therefore necessary to modify the bolt by copying the military type, or replace it with a military bolt that has an un-machined disconnecting shoulder.

Even if the bolt has been replaced and a military trigger mechanism installed, the weapon will still not function in the selective mode, because of the index rail block on the grip frame. A pin brazed to the trigger housing (inside) also prevents further trigger pull to disengage the trigger completely from the hammer notch. The sear is mounted to the trigger.

To convert both models (H & K 91 and 93) to fire semi or full automatic selectively, both the trigger block (pin brazed inside the trigger housing) and safety lever index rail block must be removed.

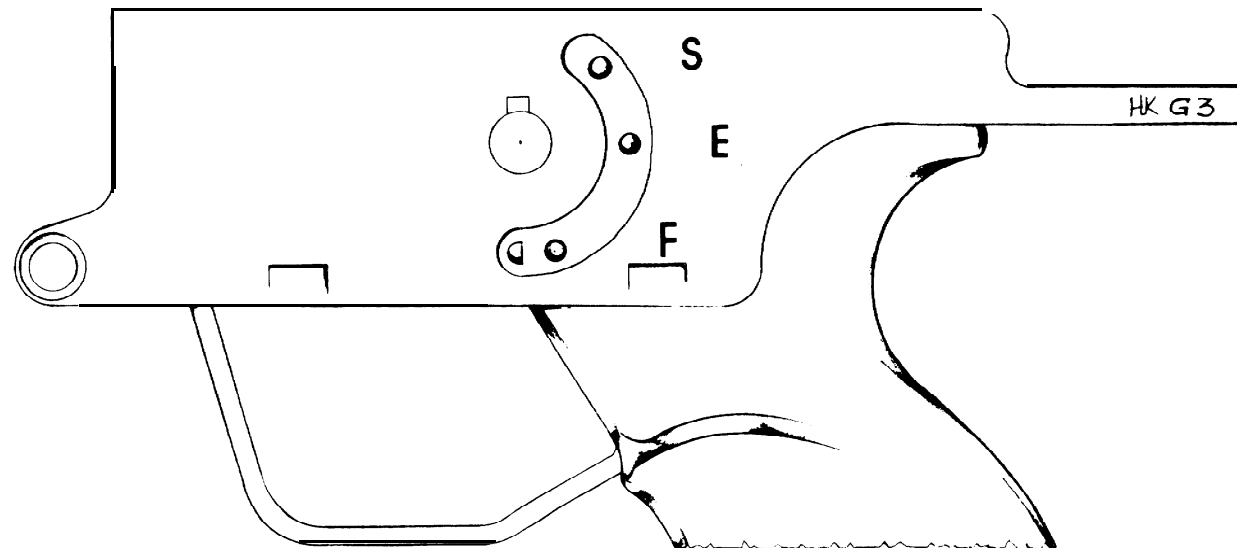

ORIGINAL MILITARY MODEL

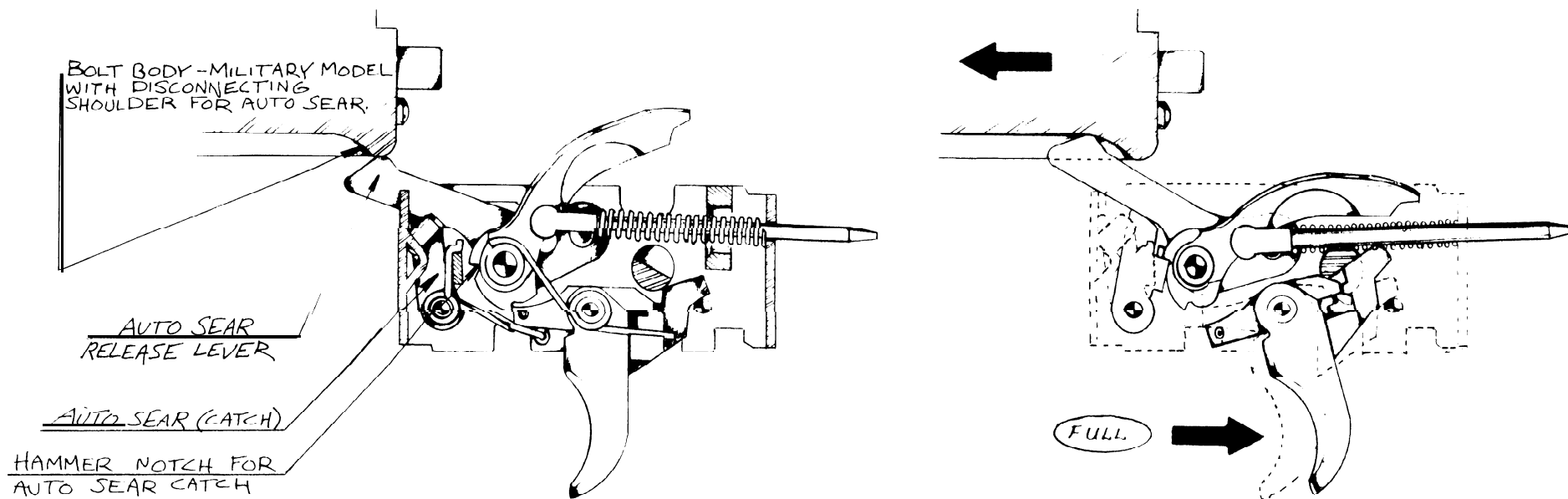

HECKLER & KOCH 91 & 93

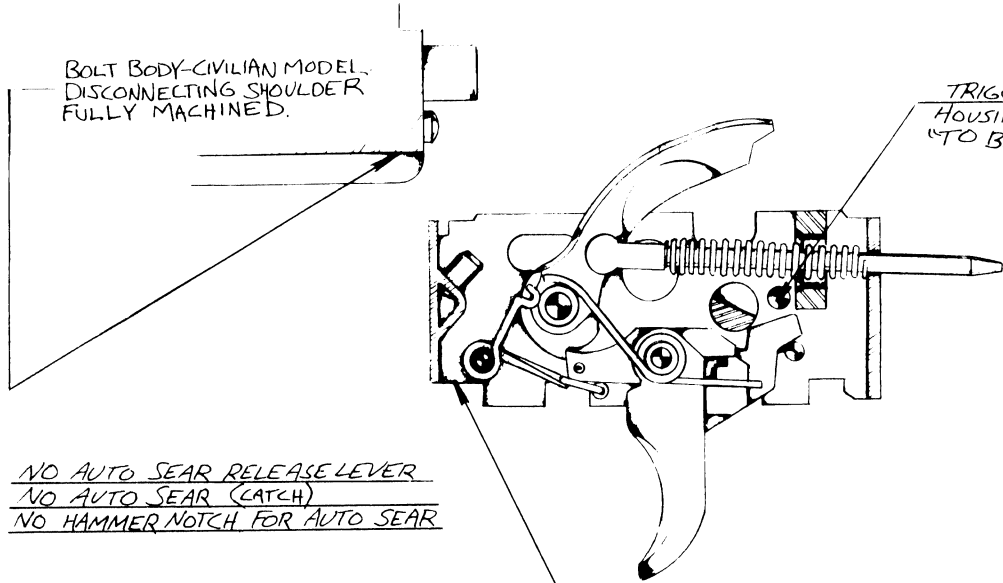

BOLT BODY-CIVILIAN MODEL.
DISCONNECTING SHOULDER
FULLY MACHINED.

TRIGGER STOP (PIN BRAZED TO RIGHT SIDE OF TRIGGER
HOUSING) RESTRICTS TRIGGER TRAVEL TO SEMI-AUTO ONLY
"TO BE REMOVED"

NO AUTO SEAR RELEASE LEVER
NO AUTO SEAR (CATCH)
NO HAMMER NOTCH FOR AUTO SEAR

HOUSING CLEARANCE CUT FOR NON PIVOT
RECEIVER HOUSING FOR CIVILIAN MODELS

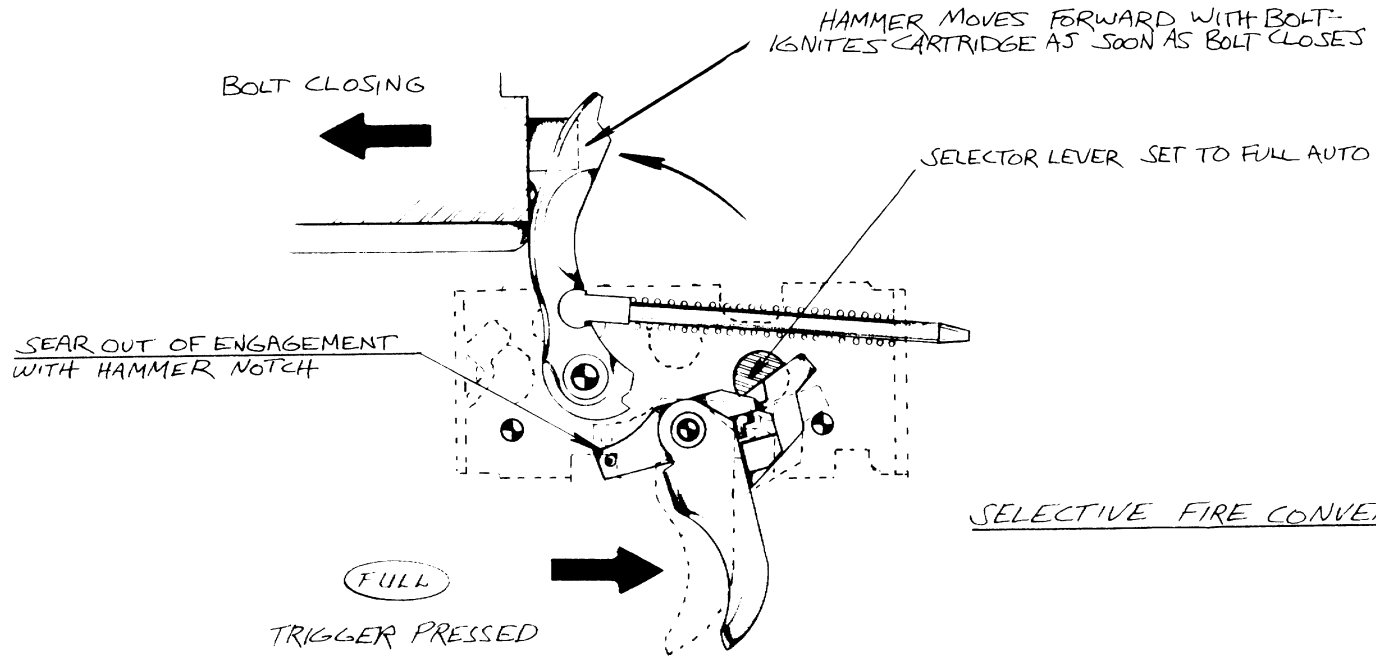

BOLT CLOSING

HAMMER MOVES FORWARD WITH BOLT-
IGNITES CARTRIDGE AS SOON AS BOLT CLOSES

SELECTOR LEVER SET TO FULL AUTO

SEAR OUT OF ENGAGEMENT
WITH HAMMER NOTCH

FULL

TRIGGER PRESSED

SELECTIVE FIRE CONVERSION

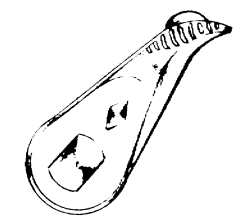
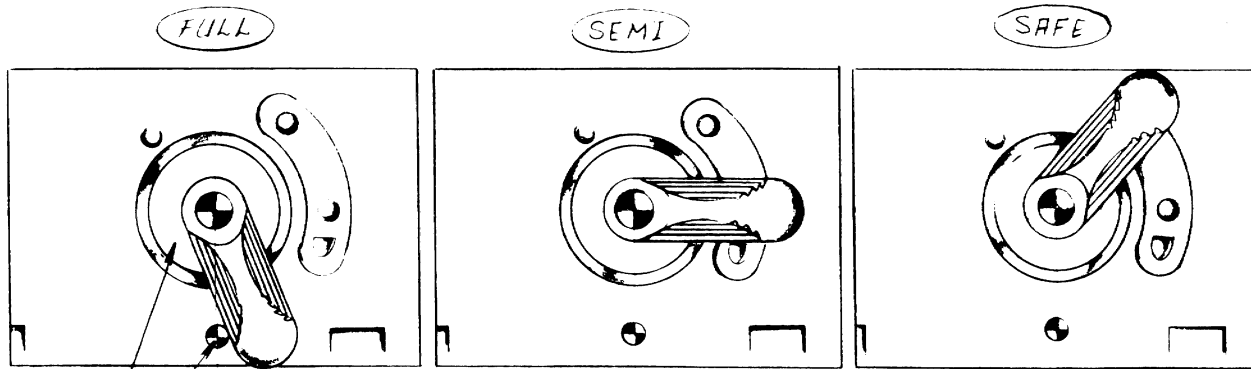

ORIGINAL "STAMPED" FACTORY SAFETY LEVER TYPE

SELECTOR STOP $\frac{1}{8}$ " DIA. PIN
 $\frac{1}{16}$ " HIGH SILVER SOLDERED IN PLACE. DRILL FRAME TO MOUNT BEFORE SOLDERING.

SELECTOR MUST COVER NEW SELECTOR INDEX HOLES

CLEARANCE FOR INDEX RAIL $.040$ "

RETAINER PIN FOR SELECTOR LEVER PIN (IF POSSIBLE ROLL PIN) $\frac{1}{16}$ " DIA.

PRESSED $\frac{1}{8}$ " DIA. DRILL ROD - SELECTOR RETAINING PIN (.085" HIGH)

INDEX BALL SPRING (MUST BE EXTRA STRONG)

Detail - SELECTOR LEVER

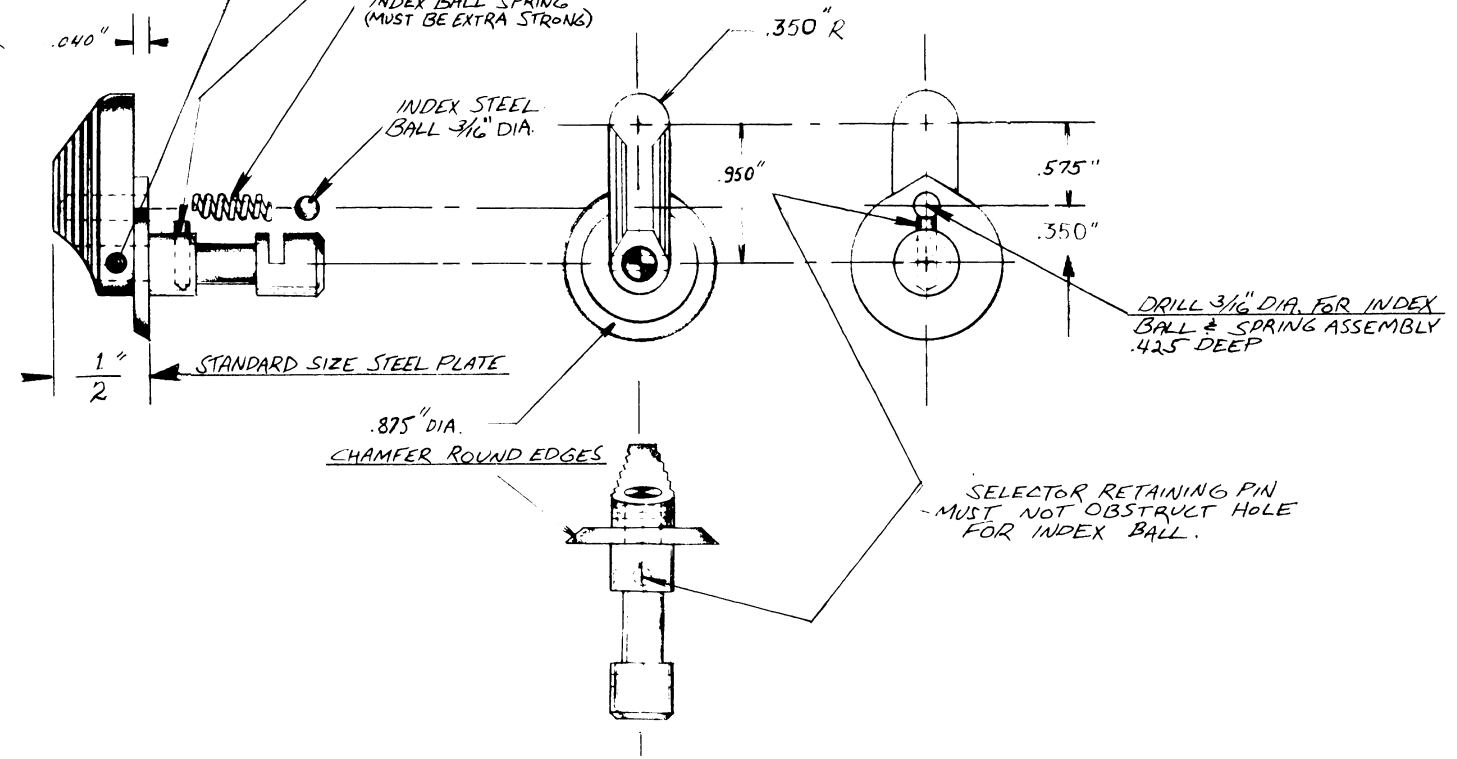

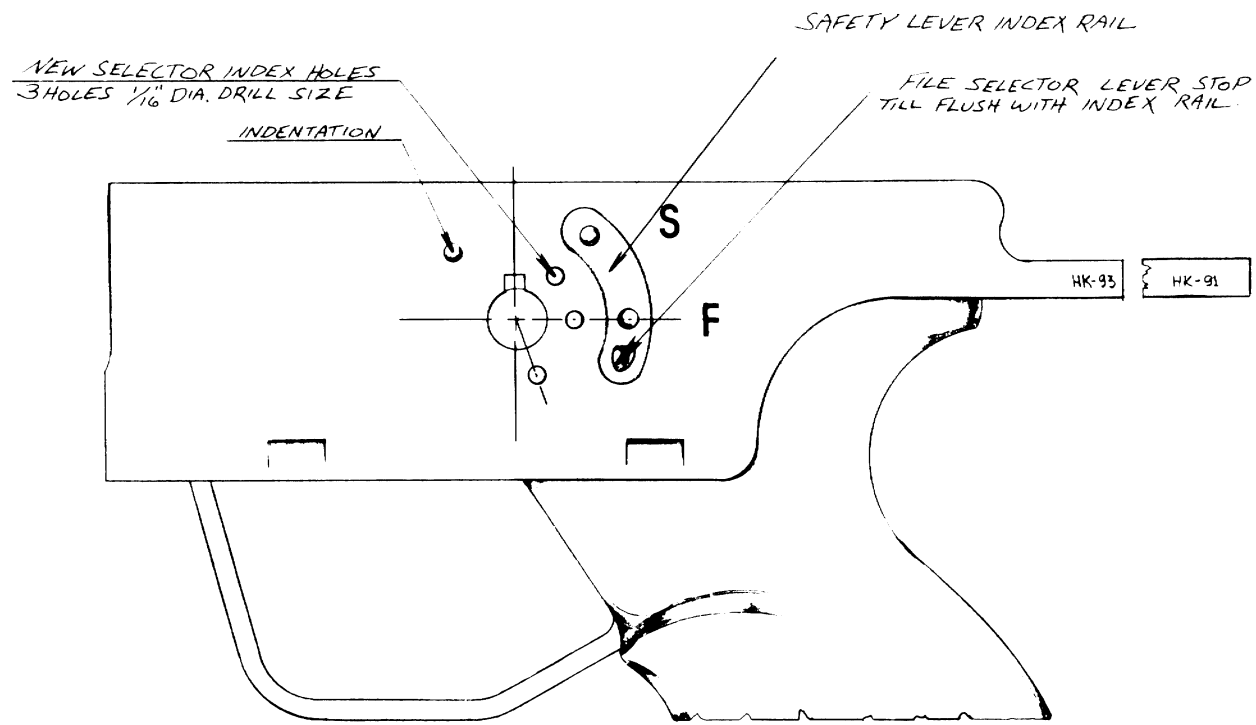

TO REMOVE:
 MARK CENTER OF TRIGGER STOP PIN
 AND DRILL WITH SAME DIA. AS OF PIN.
 IT CAN BE PUSHED OFF AS SOON AS
 DRILL PASSES THROUGH HOUSING FRAME.

RIGHT SIDE

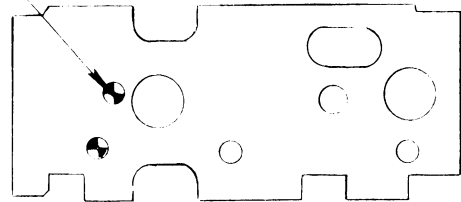

LEFT SIDE

TRIGGER TRAVEL STOP PIN - BRAZED
 TO RIGHT SIDE OF TRIGGER HOUSING

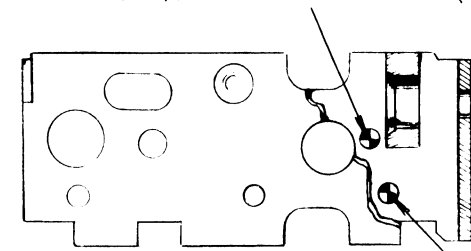

TRIGGER STOP PIN
BRAZED TO RIGHT SIDE OF HOUSING

TRIGGER HOUSING DETAIL