



US005939662A

United States Patent [19]

[11] Patent Number: **5,939,662**

Bootes et al.

[45] Date of Patent: **Aug. 17, 1999**

[54] **MISSILE WARHEAD DESIGN**

[75] Inventors: **Thomas H. Bootes**, Tucson, Ariz.; **Mel Castillo**, San Diego, Calif.

[73] Assignee: **Raytheon Company**, Lexington, Mass.

[21] Appl. No.: **08/984,100**

[22] Filed: **Dec. 3, 1997**

[51] Int. Cl.⁶ **F42B 12/04**; F42B 12/20

[52] U.S. Cl. **102/473**; 102/293; 102/481; 102/499; 102/517

[58] Field of Search 102/293, 308, 102/382, 389, 374, 376, 473, 481, 499, 500, 514, 516-519

[56] **References Cited**

U.S. PATENT DOCUMENTS

H1235	10/1993	Canaday	102/473
1,502,925	7/1924	Stone	102/517
1,861,054	5/1932	Hadfield et al.	102/517
2,120,913	6/1938	Studler	102/516
2,364,643	12/1944	Moore et al.	102/499
2,434,452	1/1948	Barber	102/389
2,682,224	6/1954	Braverman	102/507
3,349,708	10/1967	Paget	102/374
3,545,383	12/1970	Lucy	102/517
3,693,548	9/1972	Dereich et al.	102/382
4,615,272	10/1986	Aubert	102/481
5,038,686	8/1991	Zulkoski et al.	102/481
5,233,929	8/1993	Spahn	102/475
5,468,313	11/1995	Wallace, II et al.	149/53
5,528,990	6/1996	Corzine et al.	102/517
5,786,544	7/1998	Gill et al.	102/481

FOREIGN PATENT DOCUMENTS

887124	1/1962	United Kingdom	102/517
--------	--------	----------------------	---------

Primary Examiner—Harold J. Tudor

Attorney, Agent, or Firm—Glenn H. Lenzen; Andrew J. Rudd; William J. Benman

[57] **ABSTRACT**

A hard-target penetrating warhead (10) adapted for use with length constrained warhead payload bays. The warhead (10) includes a warhead case (12) for containing warhead explosives (22, 27). A tungsten ballast (16) is disposed within the case (12) for providing a high warhead sectional pressure upon impact of the warhead (10) on a target. A fuse (19) detonates the warhead explosives (22, 27) upon penetration of the target. The fuse (19) is housed by a fuse well (18) that is attached to the case (12) at one end. A slip fit section of the fuse well (18) provides structural support to the case (12) and prevents dislodging of the fuse well (18) and the fuse (19) from the case (12) upon warhead target impact. Explosives blowout ports (24) included in the fuse well (18) inhibit undesirable explosion or detonation of the warhead explosives (22, 27) by accidental exposure to high heat or fire. In a specific embodiment, the case (12) has a 6 caliber radius head nose (14). The explosives blowout ports (24) include main explosives blowout ports (24) for allowing the heat to burn the warhead explosives (22) and vent gases resulting from the burning. The main explosive blowout ports (24, 25) are placed around a circumference of the fuse well (18) and include nine ports having a surface area designed to minimize danger of explosion and/or detonation in the event of an accidental fire. The blowout ports (24, 25) also include booster blowout ports (25) for allowing safe burning of booster charge explosives (27) included in the fuse (19). Additionally, a special polyethylene/polyalphaolefin liner (20) lines the inside of the case (12) and improves fast cook-off safety performance. In the illustrative embodiment, the warhead explosives (22) include PBXN-109. The case (12) includes a textured or grooved surface that facilitates bonding of the ballast (16) to the case (12).

11 Claims, 4 Drawing Sheets

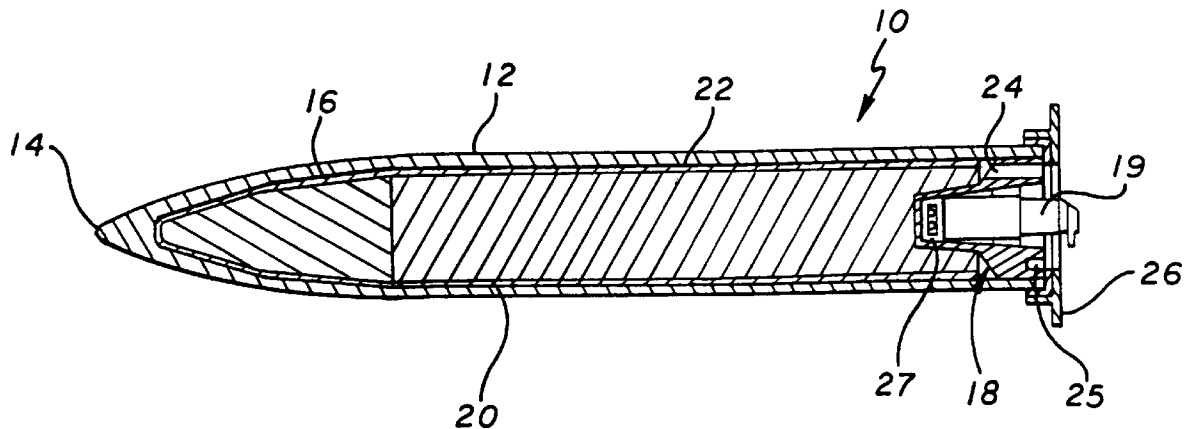

FIG. 1

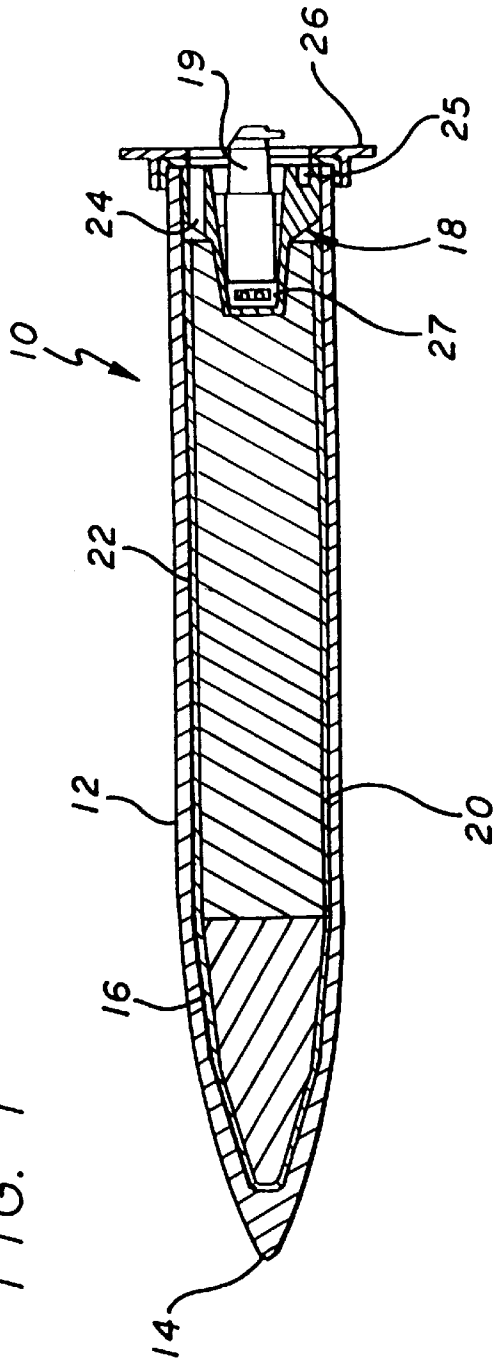
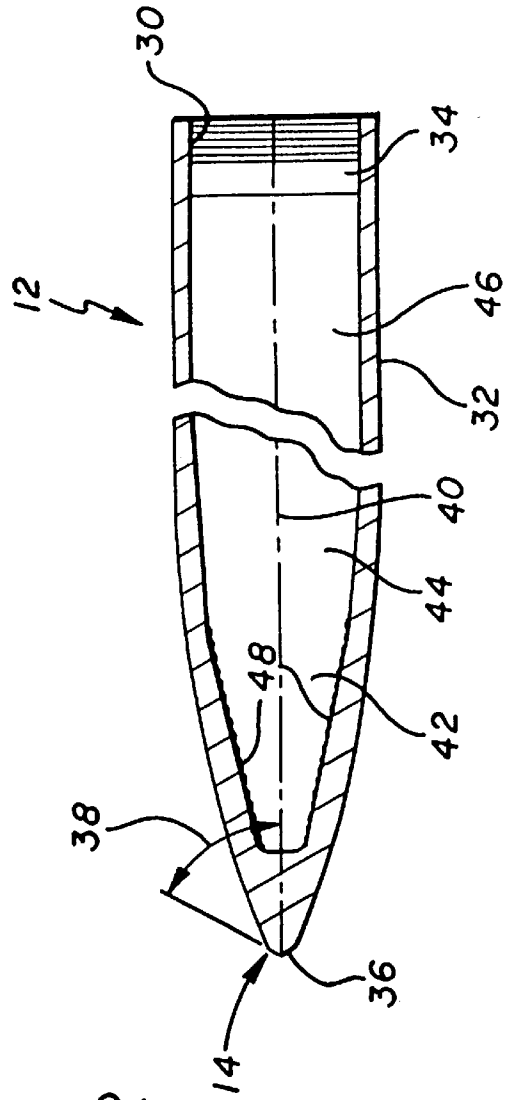

FIG. 2



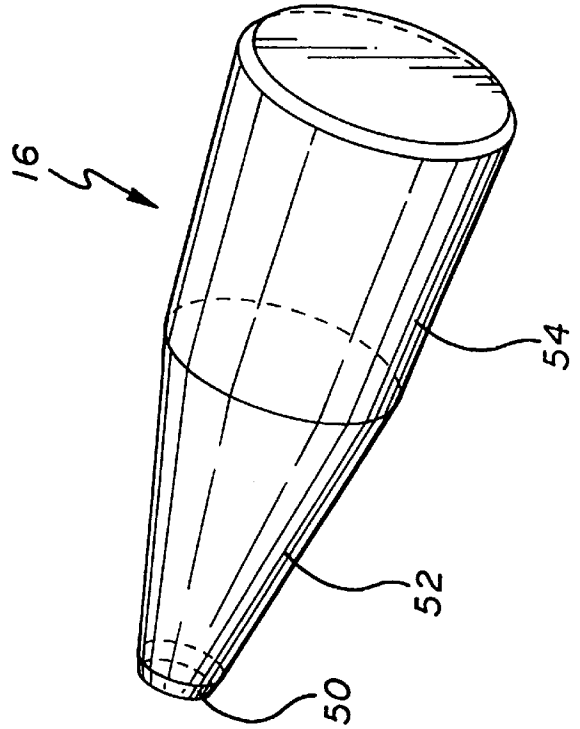
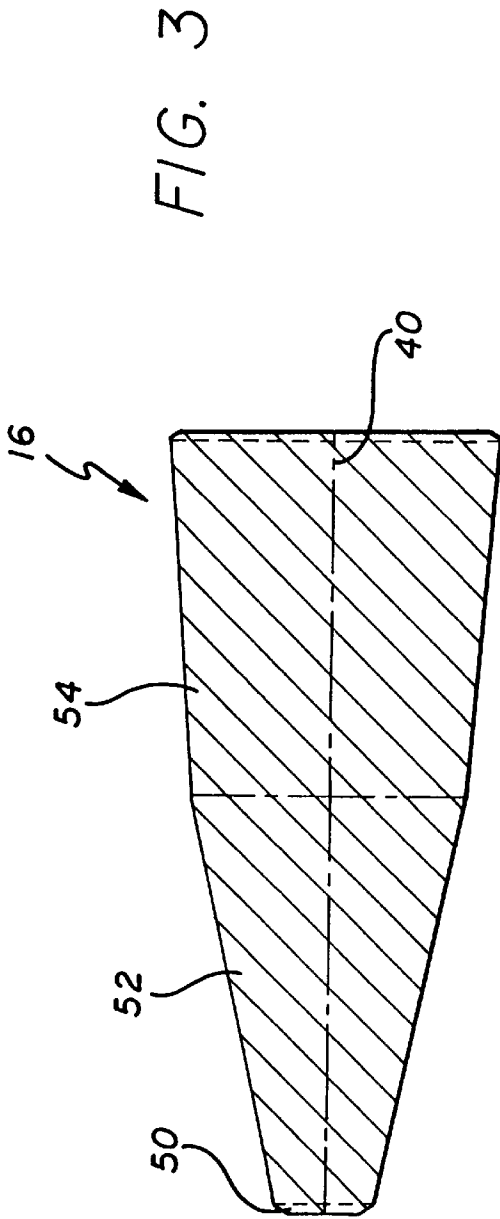

FIG. 4

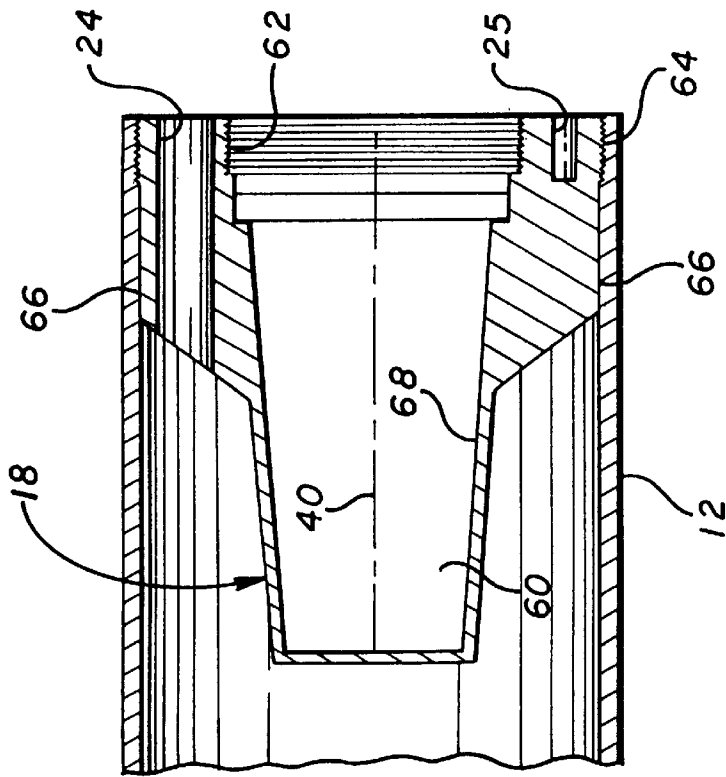

FIG. 5

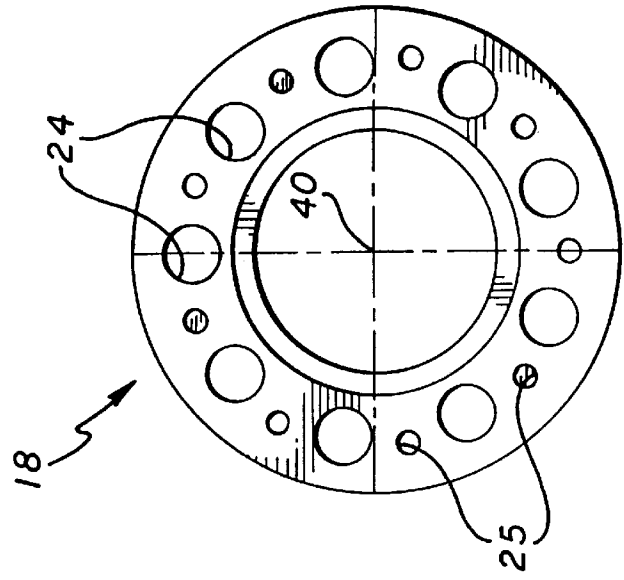
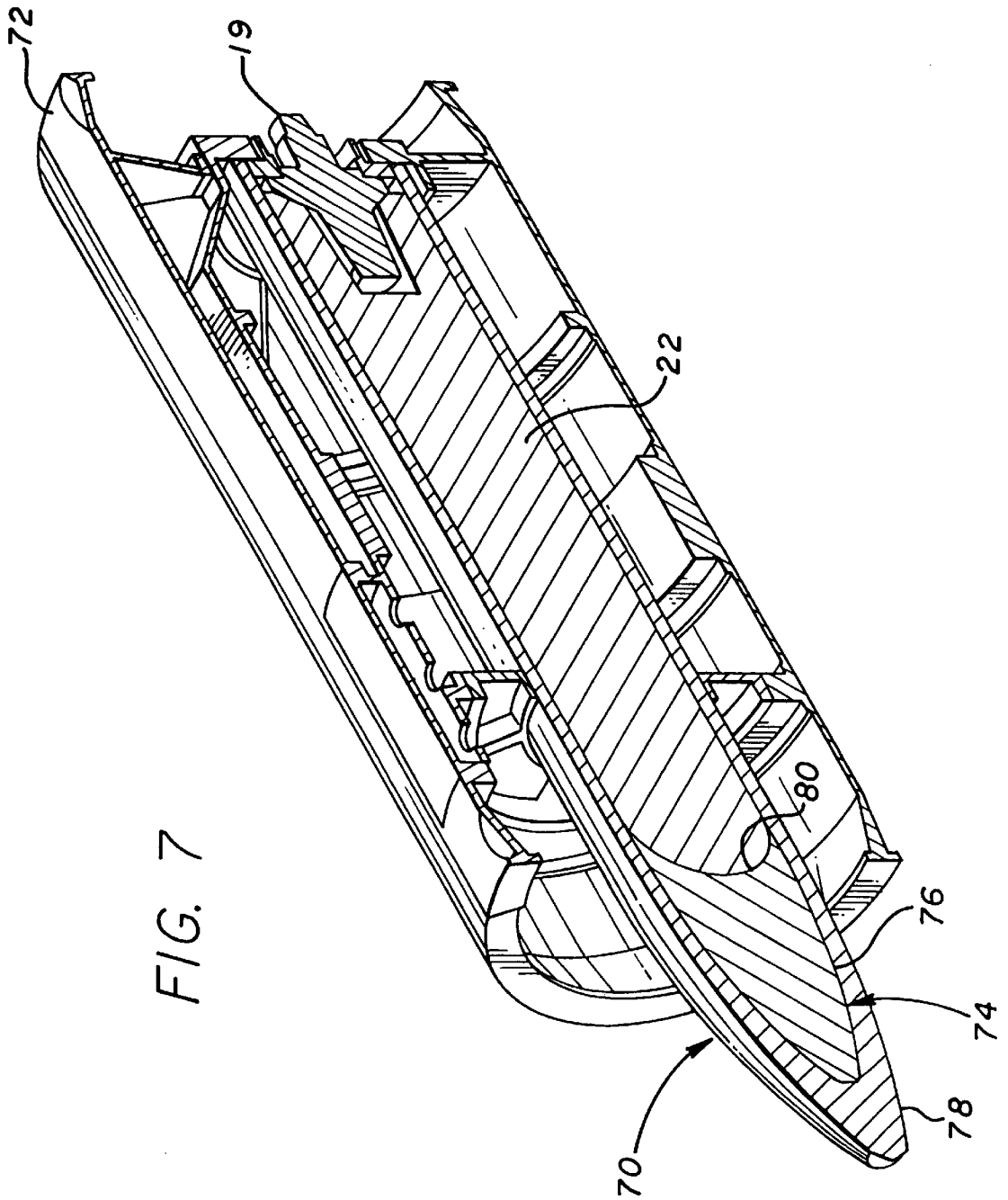

FIG. 6



MISSILE WARHEAD DESIGN

BACKGROUND OF THE INVENTION

1. Field of Invention

This invention relates to missiles. Specifically, the present invention relates missile warheads designed to penetrate hard targets.

2. Description of the Related Art

Missiles are used in a variety of demanding applications ranging from air to air and ground combat applications to structural demolition applications. Such applications often require missiles with warheads that can effectively and consistently penetrate and explode within hard targets and that may be safely transported and stored with minimal explosion danger.

A typical hard target missile includes an explosive warhead enclosed within a steel case. A fuse serves to ignite the explosive warhead following target impact. When a warhead penetrates a target, the fuse detonates a booster charge which in turn detonates the explosives in the warhead. At high target impact velocities and oblique impact angles, existing warheads may experience a slap down effect. The slap down effect causes the missile warhead case to become oval shaped as the missile slaps against the target. As a result, the fuse located in the end of the missile warhead case may become dislodged, preventing warhead detonation. Also, the warhead will often fail to adequately penetrate and destroy a target due to inadequate missile velocity or due to structural feature of the warhead that limit warhead sectional pressure. (Sectional pressure is related to the pressure that a warhead exerts on a target at impact and is expressed in terms of weight per unit area). An example of such a structural feature that can limit the penetration of a warhead is the larger diameter warhead case used on traditional warheads.

To improve warhead target penetration, designers attempted to increase missile velocity. However, this proved expensive and difficult due to missile delivery system limitations and existing missile payload length constraints.

In addition, missiles are often launched from a variety of Navy and Air Force launch platforms. The capacity of these launch platforms acts as a missile design constraint limiting the length and diameter of the missiles.

During worst case storage or transport conditions, the warheads may be exposed to fire or other extreme heat, creating hot spots in the explosive fill. These hot spots may lead to unintentional warhead detonation.

To increase missile safety, designers often employ stress risers. A stress riser is implemented via a groove in the missile case. When the case is exposed to fire or another heat source, the explosives expand and crack the missile case at the groove. The explosives then slowly burn and vent through the crack in the missile case, thereby avoiding undesirable detonation of missile explosives. The stress riser however, acts as a failure joint upon warhead hard target impact. This reduces target penetrating capability.

Hence, a need exists in the art for a safe and cost effective warhead adaptable to existing missile payload sections that can reliably and consistently penetrate a wide variety of hard targets.

SUMMARY OF THE INVENTION

The need in the art is addressed by the hard-target penetrating warhead of the present invention. In the illustrative embodiment, the inventive system is adapted for use

with length constrained missile payload bays and includes a warhead case for containing explosives. A tungsten ballast is inserted within the case to provide a high warhead sectional pressure upon impact of the missile against a target. A fuse detonates the warhead explosives following penetration of the target. A fuse well houses the fuse and is attached to the case at one end. A slip fit section of the fuse well provides structural support to the case and prevents dislodging of the fuse well and the fuse from the case upon missile target impact. Explosives blowout ports included in the fuse well inhibit undesirable detonation of the warhead explosives by accidental exposure to high heat.

In a specific embodiment, the case includes a 6 caliber radius head nose. The fuse well includes main explosives blowout ports for allowing accidental exposure to high heat to burn the missile explosives and safely vent gases resulting from the burning. The main explosives blowout ports are placed around a circumference of the fuse well and include nine ports having a surface area designed to prevent undesirable detonation. The blowout ports also include booster blowout ports for allowing safe venting of booster charge explosives that are included in the fuse. Additionally, a special polyethylene/polyalphaolefin liner lines the inside of the case for improving safe venting performance under fast cook-off hazardous conditions. The warhead explosives include PBXN-109. The case includes a textured or lightly grooved surface for facilitating bonding of the ballast to the case.

BRIEF DESCRIPTION OF THE DRAWINGS

FIG. 1 is a cross-sectional diagram of a warhead constructed in accordance with the present invention.

FIG. 2 is a more detailed cross-sectional diagram of the case of the warhead of FIG. 1.

FIG. 3 is a more detailed cross-sectional diagram of the ballast of FIG. 2.

FIG. 4 is an isometric view of the ballast of FIG. 3.

FIG. 5 is more detailed diagram of the fuse well of the warhead of FIG. 1.

FIG. 6 is a back view of the fuse well of FIG. 5.

FIG. 7 is a three-dimensional cross-sectional diagram of an alternative embodiment of the warhead of the present invention secured in a Tomahawk payload section.

DESCRIPTION OF THE INVENTION

While the present invention is described herein with reference to illustrative embodiments for particular applications, it should be understood that the invention is not limited thereto. Those having ordinary skill in the art and access to the teachings provided herein will recognize additional modifications, applications, and embodiments within the scope thereof and additional fields in which the present invention would be of significant utility.

FIG. 1 is a cross-sectional diagram of a warhead 10 constructed in accordance with the present invention. The warhead 10 includes a case 12 having a special nose 14, a tungsten ballast 16 inserted within the case 12 near the special nose 14, a unique fuse well 18 at the opposite end of the case 12, an internal liner 20, and specially selected high explosives 22 surrounded by the liner 20.

The case 12 is a 330 pound penetrating thick-walled case constructed of 4340 mod aircraft quality steel alloy. The special nose 14 is a 6 caliber radius head nose (6 CRH, an arc with a radius of 6 times the diameter of the warhead) designed for maximum warhead penetration. The tungsten

ballast **16** weighs approximately 240 pounds, and in combination with the nose **14** results in very high warhead sectional pressure. The tungsten ballast **16** and the special nose **14** provide significantly more target penetration than existing warheads whose lengths are constrained by payload bays or other factors.

The tungsten ballast **16** is approximately 2.4 times more dense than steel facilitating a shift of the center of gravity of the warhead forward and allowing carriage of up to 40% more explosives. By selectively concentrating missile mass near the nose of the warhead **10**, warhead terradynamic stability is enhanced which improves warhead penetration, and in turn expands the target set, i.e., the set of targets that may be successfully attacked by the warhead **10** carrying more explosives. For example, the warhead **10** may be used to attack hardened or layered targets whereas comparable length constrained missiles are often ineffective at penetrating and destroying these targets.

The special liner **20** is a polyethylene/polyalphaolefin film that surrounds the explosives **22**. The liner **20** may be sprayed or poured on the interior of the case **12** before missile assembly. The liner **20** helps reduce the probability that the explosives **22** will unintentionally detonate due to exposure to any accidental external heat source.

To further increase the safety of the warhead **10**, a fuse body **19** includes explosives blowout ports **24**. The ports **24** allow heat to enter the fuse body **19** and slowly burn booster charge explosives **27**. The process by which the main explosives **22** burn is known as a 'cook-off'. In the event of a fire, the explosives **22** burn-off quickly without exploding. If the explosives **22** are not allowed to burn, resulting hot spots in the explosives **22** may lead to unintentional warhead detonation. Booster charge blowout ports **25** allow for fast cook-off burning of the booster charge explosives **27**.

The fuse well **18** screws into the case **12** and is uniquely designed to provide additional structural support to the case **12** (as discussed more fully below) thereby preventing undesirable dislodging of the fuse well **18** from the warhead **10**. A retention plate **26** screws onto the end of the warhead **10** and helps to secure the warhead case **12** in the missile payload bay (see **72** of FIG. **7**). In the present specific embodiment, the fuse well **18** is designed to accommodate a standard FMU-148/B fuse **19**.

The warhead **10** is part of a missile system (not shown) that includes a guidance control system having a guidance control processor and aerodynamic fins, and a propulsion system having an engine and fuel system.

FIG. **2** is a more detailed cross-sectional diagram of the case **12** of the warhead **10** of FIG. **1**. In the present specific embodiment, the case **12** is adapted for use with Tomahawk payload sections and includes inside threads **30** that extends approximately 1.5 inches from the end of the case **12**. Threads on the outside of the fuse well (see FIG. **1**) match the threads **30**.

The case **12** has a main cylindrical body **32** having an outside and inside diameter of approximately 8.7 inches 7.2 inches, respectively. A fuse well slip fit section **34** of the body **32** has an inside diameter of approximately 7.214 inches. The slip fit section **34** is designed to accommodate a corresponding slip fit section of the fuse well as discussed more fully below.

In the present specific embodiment, the case **12** is 61.5 inches long and is constructed of aircraft quality 4340 steel alloy heat treated to Rockwell C40 +/-2, per MIL-H-6875. The nose **14** includes a conical bevel **36** the surface of which forms an angle **38** of approximately 62.5 degrees with respect to a longitudinal missile axis **40**.

The case **12** includes a first cavity section **42** that begins approximately 4.5 inches from the end of the nose **14** and extends approximately 9 inches. The first cavity section **42** is shaped like a section of a cone having a vertex angle of approximately 25.1 degrees. The first cavity section **42** ends to where the case **12** has an inside diameter of approximately 6.0 inches where a second cavity section **44** begins. The second cavity section **44** extends 8.0 inches along the longitudinal axis **40** and ends where the case **12** has an inside diameter of approximately 7.2 inches. The cavity section **44** is shaped like a section of a cone having a vertex angle of approximately 4.3 degrees.

A third cavity section **46** corresponds to the main body **32** and extends from the second section **40** to the slip fit section **34** and is cylindrical having an inside diameter of approximately 7.2 inches. The third cavity section **46** is designed to accommodate high explosives; the first **42** and second **44** cavity sections are designed to accommodate the unique tungsten ballast (see FIG. **1**); and the threaded section **30** and slip fit section **34** are designed to accommodate the unique fuse well (see FIG. **1**) of the present invention.

The case **12** may be welded together in sections, may be machined from solid stock, or may be cast. The novel design of the present invention is facilitated by a texture of slight grooves **48** that facilitate bonding of the tungsten ballast to the case **12** via high strength industrial epoxy adhesives.

FIG. **3** is a more detailed cross-sectional diagram of the ballast **16** of FIG. **2**. The ballast **16** includes a first conical section **50**, a second conical section **52**, and a third conical section **54**. The first **50** and second **52** and conical sections fit the first cavity section of the missile case (see **42** of FIG. **2**). The third conical section **54** fits the second cavity section of the missile case (see **44** of FIG. **2**). The surfaces of the first **50**, second **52**, and third **54** conical sections are roughened to improve the bonding to the corresponding cavity sections.

The first conical section **50** extends approximately 0.24 inches from the end of the ballast **16** as the diameter expands from approximately 1.57 inches to 2.17 inches. The second conical section **52** extends approximately 8.8 inches from the end of the first conical section **50** as the diameter of the second conical section **52** expands from approximately 2.17 inches to approximately 5.98 inches. The third conical section **54** extends approximately 7.75 inches from the end of the second conical section **52** as the diameter expands from approximately 5.98 inches to approximately 7.18 inches. The total length of the ballast is approximately 16.8 inches.

Once the ballast **16** is installed in the case **12** of FIG. **2** the special polyethylene/polyalphaolefin liner is poured or sprayed on the interior of the case in preparation for the PBXN-109 explosives fill (see **22** of FIG. **2**).

The ballast **16** is constructed of tungsten IAW MIL-T-21014D CLASS 4 cast and machined into the appropriate dimensions. The ballast **16** was designed to maximize ballast effectiveness while minimizing costs, however those skilled in the art will appreciate that other ballast shapes may be used without departing from the scope of the present invention. In addition, other ballast sizes and other materials such as lead or depleted uranium may be used without departing from the scope of the present invention.

FIG. **4** is an isometric view of the ballast of FIG. **3**.

FIG. **5** is more detailed diagram of the fuse well **18** of the warhead **10** of FIG. **1**. The fuse well **18** includes a chamber **60** for housing a fuse and a booster charge (see FIG. **1**) Internal threads **62** facilitate securing of the fuse in the

chamber **60**. External threads **64** help secure the fuse well **18** into the case **12** and match the threads **30** of FIG. **2**. A slip fit portion **66** of the fuse well **18** is approximately 7.21 inches in diameter and fits into the corresponding slip fit section **34** of the case **12** of FIG. **2** providing additional structural support to the case. The additional support increases the ability of the warhead to survive high impact stresses while maintaining superior penetration performance.

In the event of accidental fire, the explosives blowout ports **24** allow heat to enter the warhead, burn explosives in the warhead, and allow gases from the burning explosives to safely vent out of the warhead. This reduces the probability of unintentional warhead detonation. The booster blowout ports **25** within the fuse body **19** serve a similar function as the explosives blowout ports **24** but are designed to prevent unintentional detonation of the fuse's booster charge.

The fuse well **18** is approximately 8.29 inches long. Chamber walls **68** are approximately, 0.09 inches thick. The outside diameter of the fuse well **18** is about 7.6 inches. The fuse well **18** may be cast in sections and welded together, may be cast as a single piece, or may be machined. The preferred construction material is 17-4 PH stainless steel with a passivate QQ-P-35 finish of type I, II, or III.

FIG. **6** is a back view of the fuse well **18** of FIG. **5**. The explosives blowout ports **24** are co-axial with the longitudinal axis **40** of the warhead and are positioned around the circumference of the fuse well **18** and include **9** blowout ports placed in 40 degree intervals around the circumference. The 6 booster blow out ports **25** are an integral part of the fuse (see **19** if FIG. **1**). The centers of the explosives blowout ports **24** are positioned approximately 2.9 inches from the longitudinal axis **40**.

FIG. **7** is a three-dimensional cross-sectional diagram of an alternative embodiment **70** of the warhead of the present invention secured in a Tomahawk Cruise Missile payload section **72**. The warhead **70** includes a tungsten ballast **74** having a front continuously tapered surface **76** and a rear indentation having a second tapered surface **80**. The external dimensions of the warhead **70** are similar to those of the missile **10** of FIG. **1**, and are limited by the pre-existing size of the Tomahawk payload section **72**.

Thus, the present invention has been described herein with reference to a particular embodiment for a particular application. Those having ordinary skill in the art and access to the present teachings will recognize additional modifications, applications and embodiments within the scope thereof.

It is therefore intended by the appended claims to cover any and all such applications, modifications and embodiments within the scope of the present invention.

Accordingly,

What is claimed is:

1. A missile warhead weighing more than 570 pounds having a length to diameter ratio of approximately 7, and a 6 caliber radius head nose comprising:

case means for containing explosives;

a tungsten ballast weighing approximately 240 pounds disposed within said case means for providing a high missile sectional pressure upon impact of said missile on a target;

detonating means disposed within the case means for detonating said missile explosives upon penetration of said target, and

fuse well means attached to said case means at one end for housing said detonating means.

2. The invention of claim **1** further including support means for providing structural support to said case means for preventing dislodging of said fuse well means and said detonating means upon said impact of said missile warhead.

3. The invention of claim **2** wherein said support means includes a slip fit portion of said fuse well means that slips inside of said missile warhead case means reducing missile warhead case deformations due to slap down loads.

4. The invention of claim **1** further including safety means for inhibiting undesirable explosion or detonation of said missile warhead explosives by said detonating means and/or by exposure to heat.

5. The invention of claim **4** wherein said safety means includes blowout ports in said fuse well means.

6. The invention of claim **5** wherein said blowout ports include main explosive blowout ports for allowing said heat to burn said missile warhead explosives and safely vent gases resulting from said burning.

7. The invention of claim **6** wherein said main explosive blowout ports are placed around a circumference of said fuse well means and include nine ports having a surface area designed to minimize explosives explosion and/or detonation hazards.

8. The invention of claim **4** wherein said safety means includes a liner that lines the inside of said case means for improving fast cook-off performance in the event of an accidental fire or exposure to an extreme heat source.

9. The invention of claim **8** wherein said liner is polyethylene/polyalphaolefin.

10. The invention of claim **1** wherein said missile explosives include PBXN-109.

11. The invention of claim **1** wherein said case means includes a textured or grooved surface for facilitating bonding of said ballast means to said case means.

* * * * *