

[72] Inventor **Harold W. Euker**
Palos Verdes Estates, Calif.
 [21] Appl. No. **665,193**
 [22] Filed **Aug. 24, 1967**
 [45] Patented **Mar. 16, 1971**
 [73] Assignee **North American Rockwell Corporation**

1,287,372 12/1918 McGaw 102/66
 2,445,312 7/1948 Cooke et al..... 102/6
FOREIGN PATENTS
 298,090 2/1920 Germany..... 102/6

Primary Examiner—Samuel W. Engle
Attorneys—William R. Lane, Allan Rothenberg and Richard D. Seibel

[54] **EXPLOSIVE APPARATUS**
 6 Claims, 7 Drawing Figs.

[52] U.S. Cl..... **102/6,**
 102/66, 102/68
 [51] Int. Cl..... **F42b 25/14**
 [50] Field of Search..... 102/6, 9,
 24, 66, 67, 68, 34.4, 90; 181/5 (L2)

[56] **References Cited**
UNITED STATES PATENTS

2,372,264	3/1945	Firth.....	102/6
2,535,309	12/1950	Mari.....	102/34.4
2,742,856	4/1956	Fieser et al.	102/6
2,972,949	2/1961	MacLeod.....	102/67
3,280,743	10/1966	Reuther.....	102/24(H.C.)
3,332,348	7/1967	Myers et al.....	102/6
103,477	5/1870	Link.....	102/66

ABSTRACT: A fuel-air explosive device is described wherein a body of combustible fuel is surrounded on the sides by a layer of high explosive which, upon detonation, sends a converging shock wave through the fuel and thereby disseminates the fuel radially for combustion with air. Since no oxidizer is carried in the apparatus for combustion with the fuel, high efficiency in the resultant fireball, per unit weight of weapon, is obtained. Means are also provided for simultaneously disseminating fuel upwardly for counteracting the downward velocity of an aerially delivered weapon which tends to drive the disseminating fuel into the ground with decreased efficiency. The downward velocity is countered by a layer of explosive across the forward end of the body of fuel for imparting a longitudinally upward force thereto. In another embodiment unequal explosive layers are provided at opposite ends of the body of fuel for providing both upward and downward forces thereto with a net upward force.

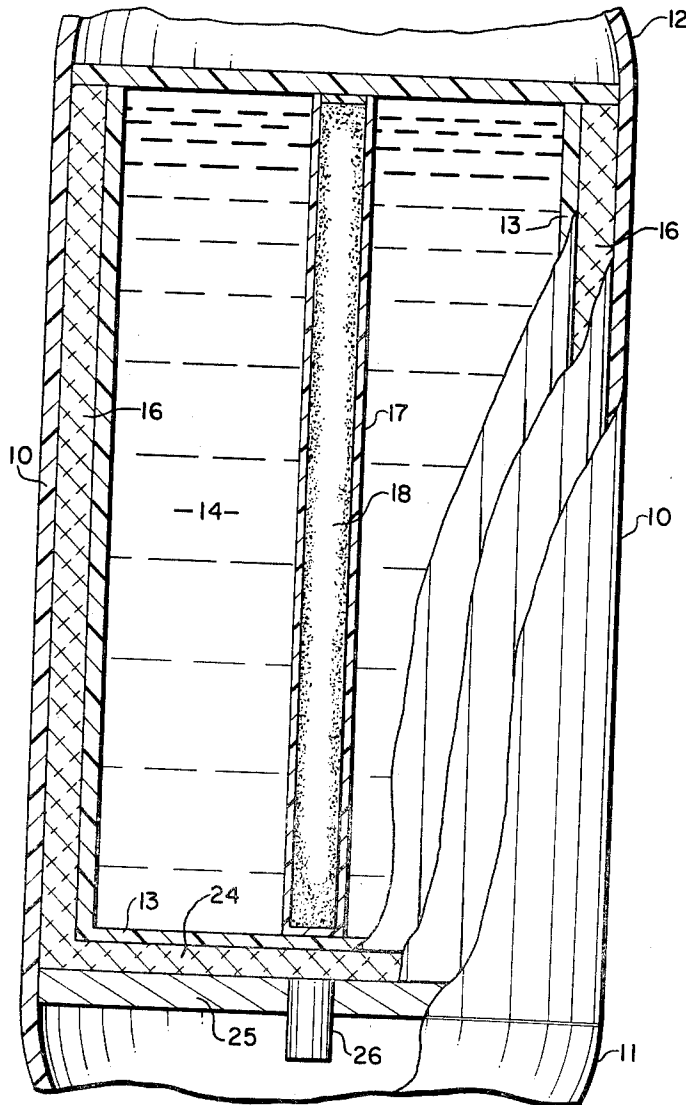

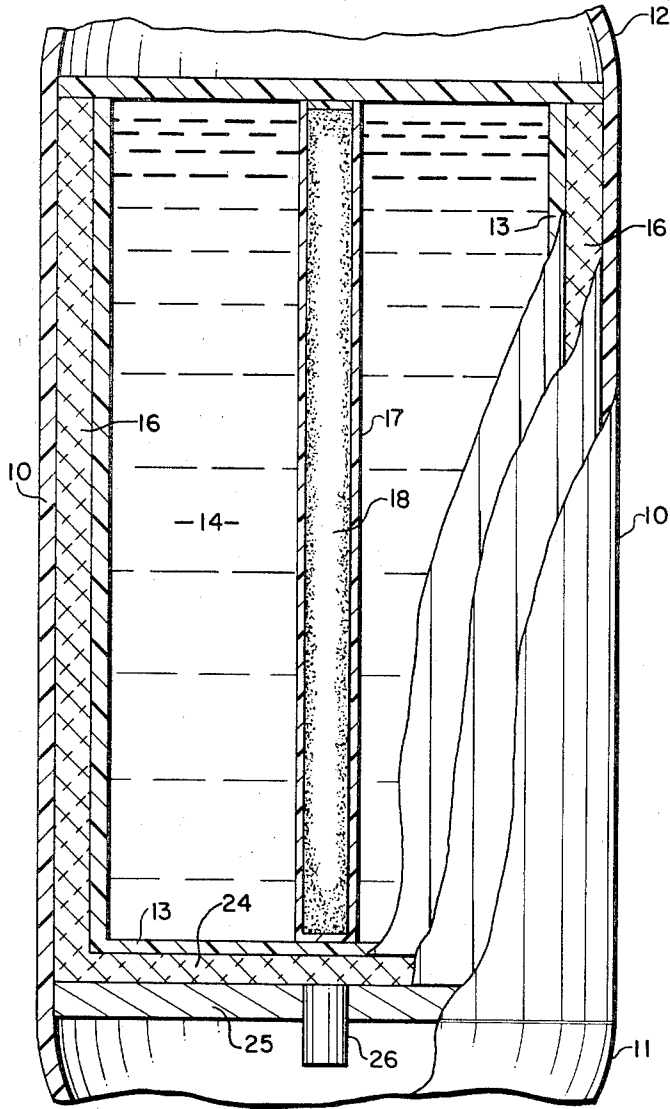

FIG. 1

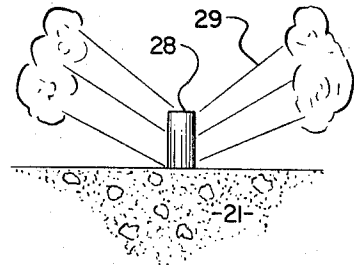

FIG. 3

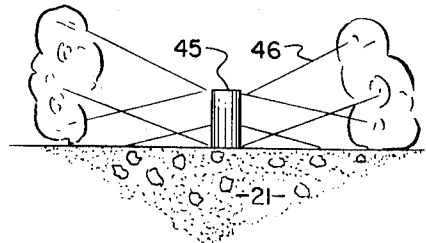

FIG. 6

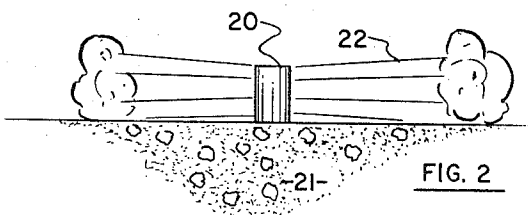

FIG. 2

INVENTOR.
HAROLD W. EUKER
BY *Richard D. Seidel*
ATTORNEY

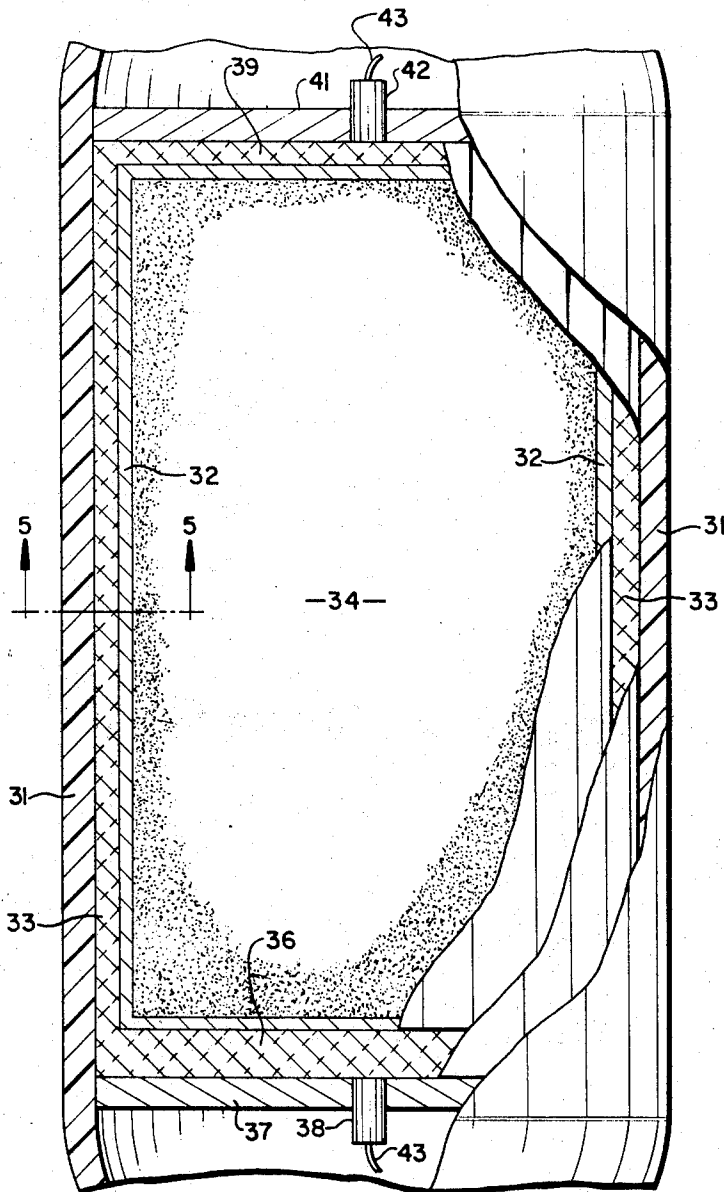

FIG. 4

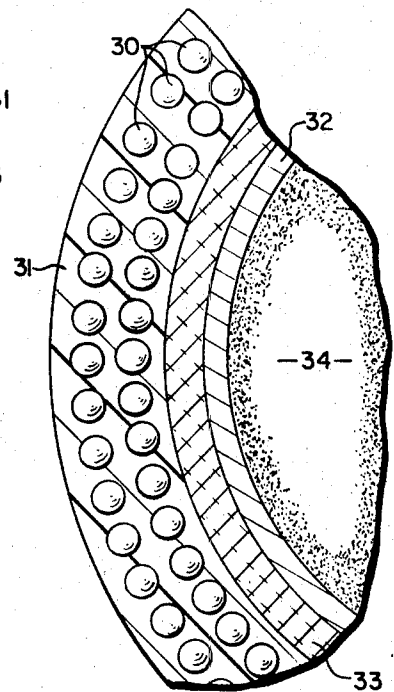

FIG. 5

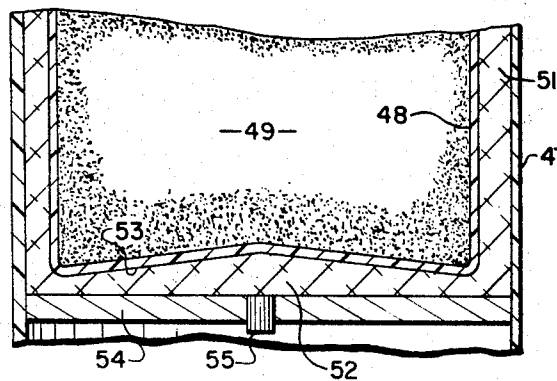

FIG. 7

INVENTOR.
HAROLD W. EUKER
BY *Richard D. Seibel*
ATTORNEY

EXPLOSIVE APPARATUS

BACKGROUND

A particularly effective aerial weapon is what is known as a fuel-air explosive device wherein a cloud of combustible fuel is disseminated in the air and ignited for providing both blast and burning effects upon targets. Good efficiency per unit weight is obtained since only fuel is carried to the target and the ambient air comprises the oxidizer for the fuel. In such a weapon the fuel is explosively disseminated in a cloud which is reacted to provide destructive forces. Detonation of the mixture of fuel and air provides a blast effect and the combustion provides a flame which produces substantial thermal damage.

In order to obtain maximum effectiveness of such weapons against most surface targets, it is desirable to disperse the fuel in a substantially pancake-shaped cloud within a few feet of the ground. It is found that since targets, such as personnel, vehicles and the like, are located at ground level, fuel disseminated at higher elevations is reacted and dissipated with little, if any, effect upon a target. In order to obtain pancake-shaped clouds of fuel an implosive technique has been devised for very rapid radial dissemination with minimized vertical displacement of the fuel. It is found with such weapons, however, when delivered from aircraft or the like, so that the impacting weapon has a substantial vertical velocity, that the pancake-shaped cloud of disseminating fuel retains a vertical velocity component from the original falling weapon and is thereby driven into the ground at a range short of the maximum range obtainable. It is therefore desirable to also provide an upward velocity component to a body of fuel that is disseminating radially.

BRIEF SUMMARY OF THE INVENTION

Thus there is provided in the practice of this invention according to a preferred embodiment an explosive apparatus for disseminating material in a substantially radial direction. Explosive means are also provided adjacent the means for radial dissemination for simultaneously effecting a longitudinal dissemination of the material.

Objects and many of the attendant advantages of this invention will be readily appreciated as the same becomes better understood by reference to the following detailed description when considered with the accompanying drawings, wherein:

FIG. 1 illustrates an implosion apparatus incorporating the principles of this invention;

FIG. 2 illustrates schematically dissemination of fuel by a prior art implosive apparatus;

FIG. 3 illustrates schematically dissemination of fuel by an apparatus incorporating the principles of this invention;

FIG. 4 illustrates another embodiment of fuel-air explosive apparatus incorporating the principles of this invention;

FIG. 5 is an enlarged section of the casing of the apparatus of FIG. 4;

FIG. 6 illustrates schematically dissemination of fuel by an apparatus as illustrated in FIG. 4, and

FIG. 7 illustrates another embodiment of explosive layer useful in the practice of this invention.

Throughout the drawings like reference numerals refer to like parts. In the practice of this invention according to a preferred embodiment there is provided an improved explosive apparatus as illustrated in FIG. 1. As illustrated therein there is provided a bomb casing 10 the center portion of which is illustrated and the conventional ends are cut away. This casing 10 may comprise a heavy plastic material such as polyethylene for ruggedness or may comprise a metal casing as will be apparent to one skilled in the art. The casing 10 includes a forward end 11 which may be streamlined if desired, and may also contain conventional arming and fusing mechanisms (not shown) as will be apparent to one skilled in the art. The aft end of the casing may be fin-stabilized or may include a drag device (not shown), such as a parachute, for stabilization of the aerial bomb in a substantially vertical direction after launching from an aircraft or the like. It will be

apparent that in lieu of an aerial bomb as described herein the principles of this invention are applicable to ballistic missiles, artillery shells, and the like.

Within the casing 10 there is provided an inner liner 13 which preferably comprises a thin plastic or metallic container such as polyethylene or aluminum substantially impervious to the particular fuel being utilized. A body of combustible fuel 14 such as, for example, napalm, gasoline, jet fuel, naphthalene, or the like is contained within the liner 13 and provides the principal yield of the weapon upon use. A cylindrical layer of explosive 16 is provided within the casing and outside the liner 13 so that the explosive 16 surrounds the body of fuel 14 on the sides thereof and is separated from the fuel by the thin liner 13. Axially located within the body of fuel 14 is a frangible plastic tube 17 containing a thermite-type mixture 18 such as copper oxide and aluminum powders intimately comixed. The thermite-type materials serve as an igniter for the fuel upon use of the weapon.

Landmines, aerial bombs, and the like employing implosive dissemination of fuel and an igniter as hereinabove briefly described are illustrated and described in greater detail in copending U.S. Pat. application Ser. No. 607,129 entitled, EXPLOSIVE APPARATUS by Jerry W. Cummings. In this copending application various structural arrangements for implosive dissemination of fuels are provided along with examples of several types of fuels and a variety of igniter materials particularly useful in the practice of this invention.

In an aerial bomb as illustrated and described to this point, conventional mechanisms of fuel dissemination and ignition are applicable. In such an apparatus upon detonation of the explosive 16 an inwardly traveling shock wave converges through the body of fuel 14 and the fuel is accelerated outwardly in a radial direction for providing a substantially pancake-shaped cloud. FIG. 2 illustrates schematically the type of cloud obtained upon dissemination of fuel from a conventional implosive type apparatus.

In FIGS. 2, 3, and 6, the schematic representation of cloud shape is illustrated for a static explosive device, such as a landmine, rather than one with a substantial vertical velocity, such as an aerial weapon. This is done for purposes of illustration since a representation of the dynamic situation is unduly complex. However, FIGS. 2, 3, and 6 can also be considered in the nature of "stopped motion" of a dynamic situation, if it is considered that the illustrated elements are all traveling downwardly toward the ground and are merely stopped for an instant for purposes of illustration.

Thus, as illustrated in FIG. 2 an explosive device 20 substantially in contact with the ground 21 provides, upon implosion, a cloud of disseminating fuel 22 lying in a flat pancake substantially parallel to the ground. It will be readily appreciated by one skilled in the art that the pancake-shaped cloud illustrated schematically in FIG. 2 is at best a transient situation since convection currents and the like will swing the cloud upwardly as its radial velocity falls off and ultimately a relatively flattened fireball will result. The initially pancake-shaped cloud of fuel from an implosive dissemination provides a flatter and more effective fireball than other dissemination techniques. It also will be apparent to one skilled in the art that if the elements of the explosive device 20 and the fuel cloud 22 have a substantial downward velocity, the fuel cloud will be driven into the ground prior to fully effective dissemination thereof.

Referring again to the device of FIG. 1, means are provided for imparting an upward vertical velocity to the body of fuel for counteracting the downward velocity due to the falling aerial weapon. Thus, at the bottom or forward end 11 of the aerial bomb illustrated in FIG. 1 there is provided a layer of explosive 24 lying across the full face of the body of fuel 14 and separated therefrom by the plastic liner 13. A metal end plate 25 is provided forwardly of the explosive layer 24 for enhancing the effectiveness of the explosive layer. The metal end plate 25 provides reflection for shock waves from the explosive layer 24 for augmenting the power of waves traveling

upward through the body of fuel. The inertia of the metal end plate 25 also assists in containing the gaseous explosion products, thereby further providing upward and outward forces on the body of fuel 14.

A conventional detonator 26 is provided in an axial hole in the metal end plate 25 for detonating the explosive layer 24. The explosive layer 24 is in contact with the explosive 16 surrounding the body of fuel 14 so that continuous detonation occurs. Preferably the explosive 16 and explosive layer 24 are cast in a single operation between the casing 10 and the liner 13.

Upon the aerial bomb reaching a target, the detonator 26 is fired by conventional means so that the explosive layer 24 is detonated. This detonation propagates to the periphery of the explosive layer 24 and upwardly along the explosive 16 surrounding the fuel 14. Thus, there is provided a converging shock wave from the explosive 16 passing radially through the body of fuel 14 and superimposed thereupon is a longitudinal shock wave passing upwardly through the body of fuel from the explosive layer 24. For purposes of discussion herein it is considered that shock waves from the several explosive layers are concurrently traveling through the body of fuel. It will be apparent to one skilled in the art, however, that shock waves upon intersecting are vectorially combined or reflected and that reference to different shock waves in the body of fuel is merely a convenience for purposes of description of the operation of the invention.

FIG. 3 illustrates schematically the shape of the cloud obtained from an explosive device as fully described and illustrated in FIG. 1. As illustrated therein, an explosive device 28 provides an essentially conical cloud 29 having an upwardly directed component as well as the radial component. Thus in a static device a substantially conical cloud is obtained, rising noticeably from the ground. It will also be apparent that if all elements of the cloud 29 are traveling downwardly in FIG. 3 with an appreciable vertical velocity as would be found in a falling aerial weapon, the net result is a radially expanding cloud, the front of which moves outwardly essentially parallel to the ground for providing an effective pancake-shaped cloud of burning fuel.

Conventional aerial weapons of this sort have a velocity at ground level in the range of about 100 to 300 feet per second, depending on the launch altitude, bomb geometry and use of drag devices for stabilization. In order to counter this downward velocity a layer of explosive at the forward end of the implosive device is provided as hereinabove described. In a typical embodiment the diameter of the body of fuel is about 12 inches and the length of the body of the fuel is in the range of from about 12 to 30 inches. With this geometry it is found that a thickness of explosive 16 of about one-half inch surrounding the body of fuel provides good implosive dissemination of the fuel over a large area for maximum effectiveness due to blast and thermal effects. A downward velocity of 100 to 300 feet per second is effectively counteracted in this size range by providing a layer of explosive 24 across the forward face of the body of fuel with the thickness of about one-quarter inch. An inertial end plate 25 of 1/2 inch thick aluminum is also provided forwardly of the explosive layer 24 for optimum action of the end explosive layer.

If it is desired to increase the longitudinal force on the body of fuel in order to counteract a higher vertical velocity a larger quantity of explosive or more powerful explosive in the explosive layer 24 can be provided. To a first approximation, countering the added momentum of fuel due to increased velocity requires a proportionally increased power of explosive. Thus for a doubled momentum of fuel in the falling aerial weapon, due either to an increase in mass of the fuel or in falling velocity, it is desirable to double the quantity of explosive in the layer 24. As indicated, this is a first approximation and somewhat more than a directly proportional increase in quantity of explosive is desirable since larger quantities of explosive expend more energy ineffectively in an apparatus of the type described than does a smaller quantity of explosive.

FIG. 4 illustrates another embodiment of aerial weapon incorporating the principles of this invention. As illustrated therein there is provided an aerial bomb having a case 31 which is preferably a relatively thick layer of plastic in which are embedded a plurality of metal fragments such as steel balls 30 as illustrated in the detailed section of FIG. 5. It will be apparent that (in lieu of balls) spikes, finned projectiles, or the like, which provide shrapnel upon detonation of the bomb, can be incorporated in the casing.

Referring again to FIG. 4, within the casing 31 is a metal liner 32 and a layer of explosive 33 is cast between the casing 31 and liner 32 for providing an implosive impulse in the manner hereinabove described in relation to FIG. 1. Within the liner 32 is a body of combustible fuel 34 for implosive dissemination by the explosive layer 33. At the forward end of the aerial bomb there is provided a layer of explosive 36 in sufficient contact with the explosive 33 surrounding the fuel for detonation to propagate therebetween. A metal end plate 37 is provided forwardly of the explosive layer 36 and a detonator 38 is provided in an axial hole in the metal plate for detonating the explosive 36.

At the opposite, upper, or aft end of the fuel body 34 there is also provided an explosive layer 39 and a metal end plate 41 for effecting longitudinal dissemination of the fuel. A conventional electric detonator 42 is provided in an axial hole in the metal plate 41, and electrical leads 43 are connected to both detonators 38 and 42 for simultaneous detonation thereof from a common fuse (not shown).

Upon contact of the aerial bomb of FIG. 4 with a target the detonators 38 and 42 are initiated thereby inducing detonation in the explosive layers 36 and 39 at the ends of the aerial bomb. This detonation propagates to the periphery of the circular layers 36 and 39 and along the length of the bomb through the layer of explosive 33. This results in an inwardly converging shock wave traveling through the body of fuel 34 for implosive dissemination of the body of fuel. Superimposed on the implosive shock wave are opposed shock waves from the end layers of explosive 35 and 39. The fuel is thus accelerated outwardly in a radially traveling cloud and a portion thereof is provided with an upward velocity component by the lower explosive layer 36 for counteracting the downward component of velocity due to the falling aerial weapon. It is found, however, with longer aerial weapons having a length-to-diameter ratio in the range of 3 or 4 that optimum effectiveness is not obtained by upward dissemination alone. It is therefore desirable to provide an explosive layer 39 at the upper end of the body of fuel for augmenting the downward velocity in at least a portion of the body of fuel. However, as illustrated in FIG. 4 it is preferred that the layer of explosive 36 at the forward or bottom end of the body of fuel be substantially thicker than the layer of fuel 39 at the upper or aft end of the body of fuel so that the net vertical velocity component imparted to the fuel is upward. The essential element is that the power provided by the explosive layers be unequal and it will be apparent that this can be accomplished by using explosives of differing power or geometry as well as by employing different thicknesses.

The cloud shape resulting from a device of the type illustrated in FIG. 4 is shown schematically in FIG. 6 wherein an explosive device 45 is immediately adjacent the ground 21 and a cloud 46 is ejected therefrom. A portion of the cloud lies along the ground and another portion extends upwardly away from the ground so that when a downward vertical velocity is superimposed on all elements of the cloud a substantial proportion of the material therein is disseminated in a substantially pancake-shaped cloud.

The functioning of such an explosive device as illustrated in FIG. 4 is readily demonstrated with an apparatus wherein the length was almost four times the diameter (60 inches long, 16 inches diameter). A surrounding layer of explosive 1/2 inch thick about a body of fuel is increased to 1 inch thickness at the bottom for providing an upward distribution superimposed on the radial dissemination. Explosion of such a device with

fragmentation particles in a casing 31 demonstrates the effectiveness of providing unequal layers of explosive at opposite ends of the body of fuel according to two criteria; a substantially uniform distribution of fragment impacts on the ground throughout the effective range of the weapon is obtained and an effective pancake-shaped cloud is also obtained.

The upward or longitudinal component of velocity imparted to the body of fuel can be controlled by controlling the power or quantity of explosive in the end layer as hereinabove described. It is also possible to control the upward velocity component by shaping the layer of explosive at the end of the body of fuel. Thus, in FIG. 7 there is illustrated a portion of an implosive-type device comprising a casing 47 having therein a plastic liner 48 in which is contained a body of fuel 49 which may, for example, be a powdered combustible solid such as naphthalene. A layer of explosive 51 is provided around the body of fuel 49 for effecting implosive dissemination thereof. An end layer of explosive 52 is also provided at the end of the body of fuel 49 for providing a longitudinal velocity component as hereinabove described. In the embodiment illustrated in FIG. 7 the surface 53 of the layer of explosive 52 nearer the body of fuel 49 has convexity, such as, for example, a shallow cone or dome, towards the body of fuel for providing both upward and outward velocity components to the fuel upon detonation of the explosive. As in the previously described embodiments a metal plate 54 is provided adjacent the explosive layer for enhancing its effectiveness and a detonator 55 is provided for initiating detonation of the explosive. Thus as will be apparent to one skilled in the art different effective longitudinal velocity components can be provided by varying the convexity of the explosive layer at the end of the body of fuel.

It will also be apparent that a substantial vertical velocity can be provided a body of fuel by providing concavity in the layer of explosive at the end of the body. This is, however, undesirable in most instances since the focusing effect of a concavity produces a geysering in the center of the body of fuel and the fuel ejected directly upwardly is wasted from the pancake-shaped cloud.

Although the combination has been described in relation to a vertically falling aerial bomb it will be apparent that the principles are applicable to roll stabilized missiles as well wherein the missile has a known attitude upon encountering the target. In such a missile the longitudinal axis of the body of fuel and surrounding explosive for radial implosive dissemination is oriented along the expected vertical and the end explosive layer is at the expected bottom for imparting a longitudinal velocity component to the fuel to counteract the downward velocity of the missile. A substantial thickness of explosive layer may be required, depending on the angle of approach, as such missiles may have a terminal velocity in the order of 1000 feet per second.

It will also be apparent that in lieu of the right circular cylinder of explosive and fuel described and illustrated that other cross sections such as squares or less symmetrical FIGS. may be employed. Further it will be apparent that the body of material within the explosive layer need not be combustible and may comprise chemical irritants for warfare or fire retardant chemicals for use in forest fires and the like.

Obviously, many modifications and variations of the present inventions are possible in light of the above teachings. It is therefore to be understood that within the scope of the appended claims the invention may be practiced otherwise than as specifically described.

I claim:

1. An aerial weapon having a forward end and a rearward end comprising:

a cylindrical casing;

a first layer of high explosive inside said casing on the radial periphery thereof, said first layer being about $\frac{1}{2}$ inch thick;

a cylindrical body of combustible fuel inwardly of said layer of explosive, said body of fuel having a diameter of at least about 1 foot;

a second layer of high explosive at the forward end of said body of fuel transverse to said first layer, said second layer being in the same order of thickness as said first layer; and

means for detonating said first and second layers of explosive substantially simultaneously, whereby said first layer of explosive sends a converging shock wave through said body of fuel for effecting radial implosive dissemination thereof and said second layer of explosive sends a shock wave rearwardly through said body of fuel for effecting rearward dissemination thereof, whereby said simultaneous disseminations produce a resultant high velocity dissemination of said fuel in a flat substantially cone-shaped cloud.

2. A weapon as defined in claim 1 further comprising: an inertial end plate adjacent said second layer of explosive for reflecting shock waves towards said body of fuel; said end plate comprising a plate of metal having a thickness in the same order of thickness as said first layer; and wherein said means for detonating comprises a detonator in said end plate for detonating said second layer of explosive.

3. A weapon as defined in claim 1 wherein said casing comprises a frangible housing around said first layer of explosives surrounding said fuel; and means imbedded in said housing for forming shrapnel upon detonation of the weapon.

4. A weapon as defined in claim 1 further comprising: a frangible tube on the axis of said body of fuel; and a thermitic type mixture in said frangible tube for igniting said fuel.

5. An explosive apparatus comprising in combination:

a casing having a longitudinal axis of symmetry;

means for exploding the apparatus with the longitudinal axis of symmetry oriented in a substantially vertical direction;

a body of disseminatable material substantially completely filling said casing and radially disposed about the longitudinal axis thereof;

a relatively thin layer of high explosive radially surrounding said body of material about the longitudinal axis and

within said casing for sending a converging shock wave through said body of material and effecting implosive dissemination thereof in a substantially horizontal direction;

a second relatively thin layer of high explosive on the bottom end of said body of material transverse to said longitudinal axis for simultaneously sending a second shock wave therethrough in a substantially vertical direction, said shock waves interacting on said body of disseminatable material to produce a flat cone-shaped cloud thereof; and

a third relatively thin layer of high explosive on the upper end of said body of material for simultaneously sending a third shock wave therethrough opposed to said second shock wave, said second layer of explosive having a greater power than said third layer of explosive for effecting a net longitudinal dissemination greater in an upward direction than in a downward direction.

6. In an aerial bomb or similar weapon adapted to be delivered to a target with a substantial downward vertical velocity substantially along an axis of the bomb including a casing, a body of fuel within the casing, a first relatively thin layer of high explosive radially surrounding the fuel about said axis for sending a converging shock wave through the fuel and effecting implosive dissemination thereof primarily horizontally from the weapon, the improvement comprising:

means for simultaneously effecting a partial upward dissemination of the fuel from the weapon comprising a second layer of high explosive at the lower end of the first layer, said second layer of explosive being very thin compared with the length of fuel in said weapon and extending substantially transverse to said axis;

a third layer of high explosive at the upper end of the first layer for effecting downward dissemination of the fuel, said third layer having less power than said second layer, and

7

means for detonating said layers of explosive substantially simultaneously, whereby a net upward dissemination is imparted to said fuel for counteracting the downward ver-

8

tical velocity and producing a flat pancake-shaped cloud of fuel.

5

10

15

20

25

30

35

40

45

50

55

60

65

70

75