



National Institute of Justice

Law Enforcement and Corrections Standards and Testing Program

Hand-Held Metal Detectors for Use in Concealed Weapon and Contraband Detection

NIJ Standard-0602.01

ABOUT THE LAW ENFORCEMENT AND CORRECTIONS STANDARDS AND TESTING PROGRAM

The Law Enforcement and Corrections Standards and Testing Program is sponsored by the Office of Science and Technology of the National Institute of Justice (NIJ), U.S. Department of Justice. The program responds to the mandate of the Justice System Improvement Act of 1979, which directed NIJ to encourage research and development to improve the criminal justice system and to disseminate the results to Federal, State, and local agencies.

The Law Enforcement and Corrections Standards and Testing Program is an applied research effort that determines the technological needs of justice system agencies, sets minimum performance standards for specific devices, tests commercially available equipment against those standards, and disseminates the standards and the test results to criminal justice agencies nationally and internationally.

The program operates through:

The *Law Enforcement and Corrections Technology Advisory Council (LECTAC)*, consisting of nationally recognized criminal justice practitioners from Federal, State, and local agencies, which assesses technological needs and sets priorities for research programs and items to be evaluated and tested.

The *Office of Law Enforcement Standards (OLES)* at the National Institute of Standards and Technology, which develops voluntary national performance standards for compliance testing to ensure that individual items of equipment are suitable for use by criminal justice agencies. The standards are based upon laboratory testing and evaluation of representative samples of each item of equipment to determine the key attributes, develop test methods, and establish minimum performance requirements for each essential attribute. In addition to the highly technical standards, OLES also produces technical reports and user guidelines that explain in nontechnical terms the capabilities of available equipment.

The *National Law Enforcement and Corrections Technology Center (NLECTC)*, operated by a grantee, which supervises a national compliance testing program conducted by independent laboratories. The standards developed by OLES serve as performance benchmarks against which commercial equipment is measured. The facilities, personnel, and testing capabilities of the independent laboratories are evaluated by OLES prior to testing each item of equipment, and OLES helps the NLECTC staff review and analyze data. Test results are published in Equipment Performance Reports designed to help justice system procurement officials make informed purchasing decisions.

Publications are available at no charge through the National Law Enforcement and Corrections Technology Center. Some documents are also available online through the Internet/World Wide Web. To request a document or additional information, call 800-248-2742 or 301-519-5060, or write:

National Law Enforcement and Corrections Technology Center
P.O. Box 1160
Rockville, MD 20849-1160
E-Mail: asknlectc@nlectc.org
World Wide Web address: <http://www.nlectc.org>

The National Institute of Justice is a component of the Office of Justice Programs, which also includes the Bureau of Justice Assistance, the Bureau of Justice Statistics, the Office of Juvenile Justice and Delinquency Prevention, and the Office for Victims of Crime.

Hand-Held Metal Detectors for Use in Concealed Weapon and Contraband Detection

NIJ Standard–0602.01

Supersedes NILECJ–STD–0602.00 dated October 1974

Nicholas G. Paulter, Jr.
Electricity Division
National Institute of Standards and Technology
Gaithersburg, MD 20899

Prepared for:
National Institute of Justice
Office of Science and Technology
Washington, DC 20531

September 2000

NCJ 183470

National Institute of Justice

Julie E. Samuels
Acting Director

The technical effort to develop this standard was conducted
under Interagency Agreement 94-IJ-R-004
Project No. 96-012-IA/CTT.

This standard was formulated by the Office of Law Enforcement
Standards (OLES) of the National Institute of Standards
and Technology (NIST) under the direction of
A. George Lieberman, Program Manager for Detection,
Inspection and Enforcement Technologies and
Kathleen M. Higgins, Director of OLES. The revision
of the standard was written by Nicholas G. Paulter of NIST.
The preparation of this standard was sponsored by
the National Institute of Justice, Dr. David G. Boyd,
Director, Office of Science and Technology.

FOREWORD

This document, NIJ Standard–0602.01, Hand-Held Metal Detectors for Use in Concealed Weapon and Contraband Detection, is an equipment standard developed by the Office of Law Enforcement Standards of the National Institute of Standards and Technology. It is produced as part of the Law Enforcement and Corrections Standards and Testing Program of the National Institute of Justice. A brief description of the program appears on the inside front cover.

This standard is a technical document that specifies performance and other requirements equipment should meet to satisfy the needs of criminal justice agencies for high-quality service. Purchasers can use the test methods described in this standard to determine whether a particular piece of equipment meets the essential requirements, or they may have the tests conducted on their behalf by a qualified testing laboratory. Procurement officials may also refer to this standard in their purchasing documents and require that equipment offered for purchase meet the requirements. Compliance with the requirements of the standard may be verified to by an independent laboratory or guaranteed by the vendor.

Because this NIJ standard is designed as a procurement aid, it is necessarily highly technical. User guides have also been published for those who seek general guidance concerning the selection and application of law enforcement equipment. The guides explain in nontechnical language how to select equipment capable of the performance required by an agency.

NIJ standards are subjected to continuing review. Technical comments and recommended revisions are welcome. Please send suggestions to the Director, Office of Science and Technology, National Institute of Justice, U.S. Department of Justice, Washington, DC 20531.

Before citing this or any other NIJ standard in a contract document, users should verify that the most recent edition of the standard is used. Write to: Director, Office of Law Enforcement Standards, National Institute of Standards and Technology, 100 Bureau Drive, Stop 8102, Gaithersburg, MD 20899–8102.

Dr. David G. Boyd, Director
Office of Science and Technology
National Institute of Justice

BACKGROUND

Following a congressional mandate (Section 402(b) of the Omnibus Crime Control and Safe Streets Act of 1968, as amended) to develop new and improved techniques, systems, and equipment to strengthen law enforcement and criminal justice, in the early 1970s, the National Institute of Law Enforcement and Criminal Justice (NILECJ) established the Law Enforcement Standards Laboratory (LESL) at the National Bureau of Standards (NBS). LESL's function was to conduct research that would assist law enforcement and criminal justice agencies in the selection and procurement of quality equipment.

In response to priorities established by NILECJ, LESL (1) subjected existing equipment to laboratory testing and evaluation and (2) conducted research leading to the development of several series of documents, including national voluntary equipment standards, user guidelines, state-of-the-art surveys, and other reports.

In October 1974, NILECJ, a predecessor organization to the National Institute of Justice (NIJ), promulgated a standard for hand-held metal detectors which consisted of performance and other requirements together with a description of appropriate test methods. This document, NILECJ-STD-0602.00, Hand-Held Metal Detectors for Use in Weapons Detection, was a law enforcement equipment standard developed by LESL and approved and issued by NILECJ.

The Law Enforcement and Corrections Technology Advisory Council (LECTAC), a technical advisory group to NIJ, recommended that NIJ revise the NILECJ-STD-0602.00, Hand-Held Metal Detectors for Use in Weapons Detection. Revisions were also requested by a number of the manufacturers of the detectors. Subsequently, NIJ contacted the Office of Law Enforcement Standards (OLES), formerly LESL, of the National Institute of Standards and Technology (NIST), formerly NBS, to develop these revised standards in coordination with the law enforcement and corrections (LEC) community.

In response to this request, NIST contacted a large number of medium to large LEC agencies (in numbers of sworn officers) to discuss their concerns and recommendations for improved standards. On the basis of these discussions and a review of other agency/organization standards, the following standard, "National Institute of Justice Standard for Hand-Held Metal Detectors for Use in Concealed Weapon and Contraband Detection," was adopted.

This equipment standard is a technical document consisting of performance and other requirements together with a description of test methods. Equipment that can meet the requirements stated herein will meet most if not all of the performance and functional requirements of the LEC community. Purchasing agents can use the test methods described in this standard to determine firsthand whether a particular equipment item meets the requirements of the standard, or they may have the tests conducted on their behalf by a qualified testing laboratory. LEC personnel may also reference this standard in procurement documents and require that any equipment offered for purchase meet its requirements and that this compliance be either guaranteed by the vendor or attested to by an independent testing laboratory.

The necessarily technical nature of this NIJ standard makes it of limited use to those who seek general information concerning hand-held metal detectors. For purchasing agents and other interested persons who need information on the operation of hand-held metal detectors, a user's guide is available. The guide provides, in nontechnical language, information for purchasing agents and other interested persons concerning the capabilities of equipment currently available, along with other useful information and can be obtained by contacting OLES/NIST or NIJ.

ACKNOWLEDGMENTS

This document, NIJ Standard–0602.01, “Hand-Held Metal Detectors for Use in Concealed Weapon and Contraband Detection,” is the result of inputs from the law enforcement and corrections (LEC) community regarding the functional and performance requirements of hand-held weapon detectors required to maintain and improve the security of correctional and public buildings and to improve the safety of the officers involved. In particular, the following local and State LEC agencies provided inputs that were used in rewriting the standard:

Allen County Sheriff's Department, Fort Wayne, IN
Arapahoe County Sheriff's Department, Littleton, CO
Buffalo Police Department, Buffalo, NY
California Department of Corrections, Sacramento, CA
Erie County Sheriff's Department, Erie County, NY
Fairfax County Sheriff's Department, Fairfax, VA
Frederick County Adult Detention Center, Frederick, MD
Los Angeles County Sheriff's Department, Monterey Park, CA
Montgomery County Police, Rockville, MD
New Hampshire Department of Corrections, Concord, NH
New York State Department of Corrections, Buffalo, NY
Rhode Island Department of Corrections, Cranston, RI
Rome Police Department, Rome, NY

The following Federal LEC agencies provided comments and inputs regarding the contents of the standard:

Bureau of Alcohol, Tobacco and Firearms, U.S. Department of Treasury
Bureau of Diplomatic Security, U.S. Department of State
Federal Aviation Administration, U.S. Department of Transportation
Federal Bureau of Investigation, U.S. Department of Justice
Federal Bureau of Prisons, U.S. Department of Justice
United States Secret Service, U.S. Department of Treasury

CONTENTS

	Page
FOREWORD	iii
BACKGROUND	v
ACKNOWLEDGMENTS	vii
COMMONLY USED SYMBOLS AND ABBREVIATIONS	xi
1. INTRODUCTION	1
1.1 Purpose of the Standard	1
1.2 Definitions	1
2. REQUIREMENTS FOR ACCEPTANCE	8
2.1 Safety Specifications and Requirements	8
2.2 Electrical Requirements	9
2.3 Detection Performance Specifications	9
2.4 Operating Requirements	11
2.5 Mechanical Specifications and Requirements	15
2.6 Functional Requirements	16
2.7 Detector Mount	18
2.8 Quality Control and Assurance	18
2.9 Documentation	19
3. PERFORMANCE TESTING PROCEDURES	22
3.1 General Test Conditions	22
3.2 Detection Performance Tests	22
3.3 Alarm Indication Tests	25
3.4 Test for Operation Near a Metal Wall	26
3.5 Battery Life Test	26
3.6 Burn-In Test	27
4. FIELD TESTING PROCEDURES	27
4.1 Large Object Size	27
4.2 Medium Object Size	27
4.3 Small Object Size	27
5. TEST OBJECTS DESCRIPTION	28
5.1 Large Object Size Test Objects	28
5.2 Medium Object Size Test Objects	33
5.3 Small Object Size Test Objects	39
5.4 Innocuous Item Test Objects	43
6. REPORT SHEETS	46
6.1 Requirements for Acceptance Report Sheet	47
6.2 Detection Sensitivity Test Report Sheet	50
6.3 Speed Test Report Sheet	51
6.4 Repeatability Test Report Sheet	52
6.5 Discrimination Test Report Sheet	53

7. REFERENCES 54

FIGURES

Figure 1. Diagram of two different hand-held metal detectors showing the detector plane and the detector axis 2

Figure 2. Drawing of the detector mount and detector positioner showing attachment at the reference surface 3

Figure 3. Diagram of measurement coordinate system showing the measurement coordinate system axes, one measurement plane, the detector plane, and the reference surface, where the detector mount, containing a detector, is unmounted 5

Figure 4. A schematic of the detector mount with detector in place and of the reference block where the detector mount is properly located on the detector positioner, that is, where: the z axis of the measurement coordinate system, the detector axis, and the reference axis are collinear; the detector mount and detector positioner are in contact at their reference surfaces; and the long axis of the detector is collinear with the x axis of the measurement coordinate system 6

Figure 5. Mechanical drawing of reference surface 19

COMMONLY USED SYMBOLS AND ABBREVIATIONS

A	ampere	H	henry	nm	nanometer
ac	alternating current	h	hour	No.	number
AM	amplitude modulation	hf	high frequency	o.d.	outside diameter
cd	candela	Hz	hertz (c/s)	Ω	ohm
cm	centimeter	i.d.	inside diameter	p.	page
CP	chemically pure	in	inch	Pa	pascal
c/s	cycle per second	IR	infrared	pe	probable error
d	day	J	joule	pp.	pages
dB	decibel	L	lambert	ppm	parts per million
dc	direct current	L	liter	qt	quart
C	degree Celsius	lb	pound	rad	radian
F	degree Fahrenheit	lbf	pound-force	rf	radio frequency
dia	diameter	lbf in	pound-force inch	rh	relative humidity
emf	electromotive force	lm	lumen	s	second
eq	equation	ln	logarithm (base e)	SD	standard deviation
F	farad	log	logarithm (base 10)	sec.	section
fc	footcandle	M	molar	SWR	standing wave ratio
fig.	figure	m	meter	uhf	ultrahigh frequency
FM	frequency modulation	min	minute	UV	ultraviolet
ft	foot	mm	millimeter	V	volt
ft/s	foot per second	mph	miles per hour	vhf	very high frequency
g	acceleration	m/s	meter per second	W	watt
g	gram	N	newton	λ	wavelength
gr	grain	N m	newton meter	wt	weight

area=unit² (e.g., ft², in², etc.); volume=unit³ (e.g., ft³, m³, etc.)

PREFIXES

d	deci (10 ⁻¹)	da	deka (10)
c	centi (10 ⁻²)	h	hecto (10 ²)
m	milli (10 ⁻³)	k	kilo (10 ³)
μ	micro (10 ⁻⁶)	M	mega (10 ⁶)
n	nano (10 ⁻⁹)	G	giga (10 ⁹)
p	pico (10 ⁻¹²)	T	tera (10 ¹²)

COMMON CONVERSIONS (See ASTM E380)

0.30480 m = 1ft	4.448222 N = 1 lbf
2.54 cm = 1 in	1.355818 J = 1 ft lbf
0.4535924 kg = 1 lb	0.1129848 N m = 1 lbf in
0.06479891g = 1gr	14.59390 N/m = 1 lbf/ft
0.9463529 L = 1 qt	6894.757 Pa = 1 lbf/in ²
3600000 J = 1 kW hr	1.609344 km/h = 1 mph

$$\text{Temperature: } T_C = (T_F - 32) \times 5/9$$

$$\text{Temperature: } T_F = (T_C \times 9/5) + 32$$

**NIJ STANDARD
FOR
HAND-HELD METAL DETECTORS FOR USE IN
CONCEALED WEAPON AND CONTRABAND DETECTION**

1. INTRODUCTION

1.1 Purpose of the Standard

The purpose of this document is to establish performance requirements and methods of test for active hand-held metal detectors used to find metal weapons and/or metal contraband carried on a person and/or concealed by a nonmetal object.

1.2 Definitions

The definitions given herein are for the purpose of this document and are written to facilitate the use and understanding of this document, which relates to active hand-held metal detectors for use as weapon detectors. Terms that are defined here appear in *italics* in the remainder of this document.

All measurement units used in this document are metric. Length units are abbreviated: meter (m), centimeter (cm), and millimeter (mm). Where useful, English units are indicated in parentheses immediately following the metric units, such as “2.54 cm (1 in).”

1.2.1 Alarm Indication

A signal to warn of the detection of a metal object. The indication can be visual and/or auditory.

1.2.1.1 Positive Alarm Indication

The change in the *alarm indication* that corresponds to the detection of a metal object. Typically, the *alarm indication* is off until a metal object is detected.

1.2.1.2 Proportional Alarm Indication

An *alarm indication* proportional to the size, proximity, orientation, and material of an object.

1.2.2 Alarm Indicator

The device used to generate the *alarm indication*. For a visual indication, the alarm generating device can be a light bulb, lamp, light emitting diode, etc. For an auditory indication, the alarm generating device can be a horn, siren, buzzer, etc.

1.2.3 Active Detector

An *active detector* is, in general, a device that generates and emits energy for illuminating the target space. For the hand-held metal detector, the emitted energy is in the form of a magnetic field. The interaction of this emitted magnetic field with certain types of objects in the region around the detector and the ability to detect this interaction is the basis of operation for hand-held metal detectors.

1.2.4 Detection

The discovery or finding of a metallic object. The detection of a metallic object is transmitted to the operator by some type of *alarm indicator*, typically a visual or audible indicator.

1.2.5 Detector Axis

An imaginary line passing through and perpendicular to the *detector plane* that is located within the *detector plane* such that the magnetic field around the *detector axis* has the maximum symmetry. The *detector axis* is labeled as the “z” axis. The location of the *detector axis* relative to the detector shape and geometry is specified by the manufacturer. See figure 1.

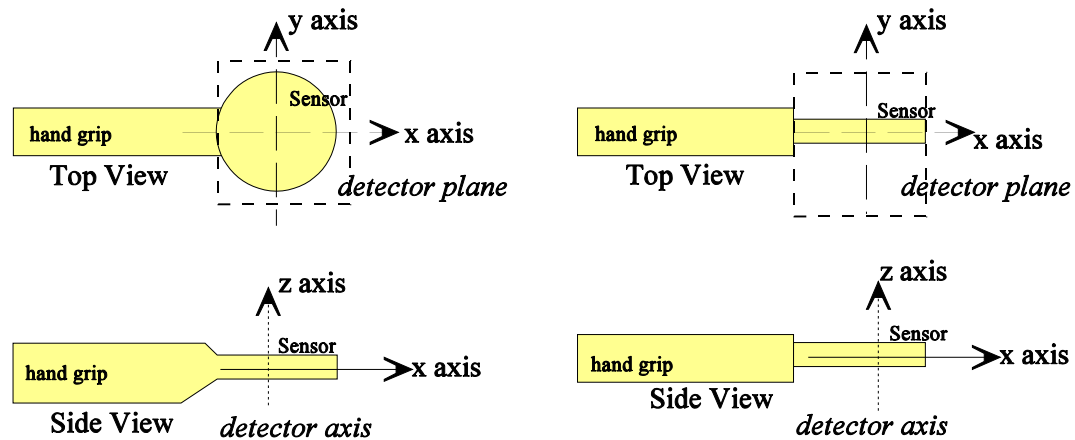

Figure 1. Diagram of two different hand-held metal detectors showing the detector plane and the detector axis

1.2.6 Detector Mount

A nonconductive, nonmagnetic block that holds the hand-held metal detector for testing. The *detector mount* is supplied by the manufacturer and contains a *reference surface* that mates to the *reference surface* of the *detector positioner*. Figure 2 shows how the *detector mount* is used and section 2.7 provides specific requirements.

1.2.7 Detector Plane

An imaginary plane (two-dimensional surface) that passes through the center of the sensor region of the hand-held metal detector, bisects the sensor region into two symmetric halves, and is parallel to the plane of the sensing element. The *detector plane* contains two orthogonal axes labeled as the “x” axis and as the “y” axis. See figure 1.

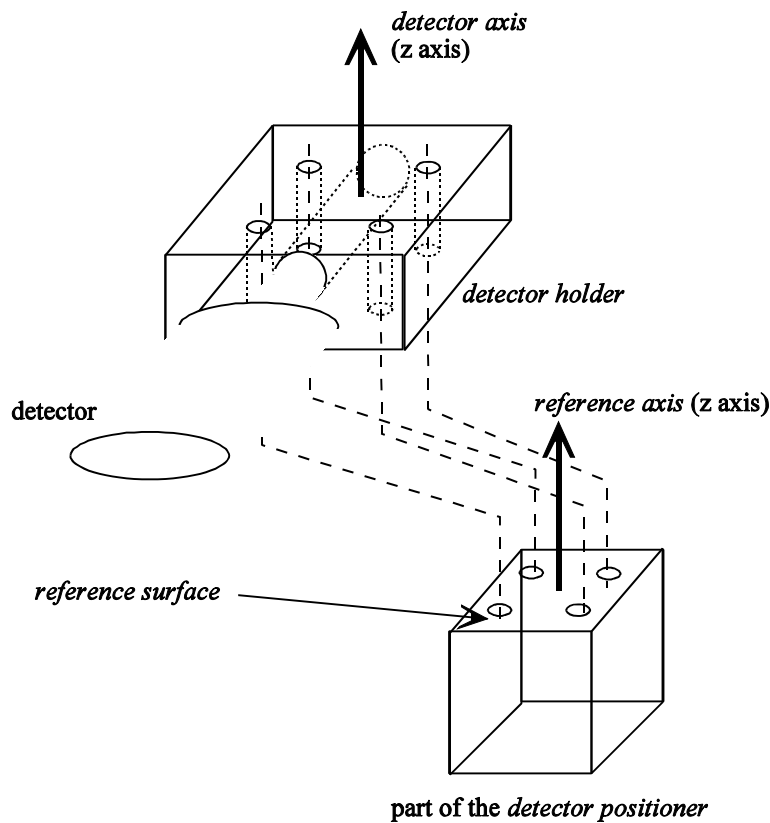

Figure 2. Drawing of the detector mount and detector positioner showing attachment at the reference surface

1.2.8 Detector Positioner

A nonconductive, nonmagnetic device that fixes the position of the *detector plane* and *detector axis* with respect to the *three-axes translation system*. The *detector positioner* includes a *reference surface* for attaching the *detector mount*. The *detector positioner* also includes a surface for attachment to the *three-axes translation system*.

1.2.9 Detector Response

The electrical signal generated by the sensor or sensor circuit of the detector that is caused by an object interacting with the magnetic field emitted by the detector. The *detector response* is the basis on which an *alarm indication* is derived.

1.2.10 Measurement Coordinate System

A mutually orthogonal three-dimensional Cartesian coordinate system referenced to the *detector axis* and the *detector plane*. The three axes are labeled “x,” “y,” and “z,” where the z axis is parallel to the *detector axis* and the x axis and the y axis are in *detector plane*. The orientation of the test objects and the direction of the magnetic field is referenced to the *measurement coordinate system*. See figure 3.

1.2.11 Measurement Plane

An imaginary two-dimensional surface over which the hand-held metal detectors are tested. There may be more than one *measurement plane*. The *measurement plane(s)* is(are) referenced from the *detector plane*. See figure 4.

1.2.11.1 Large Object Size Measurement Plane

The *measurement plane* at a *test separation distance* of 20 cm from the *detector plane*.

1.2.11.2 Medium Object Size Measurement Plane

The *measurement plane* at a *test separation distance* of 10 cm from the *detector plane*.

1.2.11.3 Small Object Size Measurement Plane

The *measurement plane* at a *test separation distance* of 5 cm from the *detector plane*.

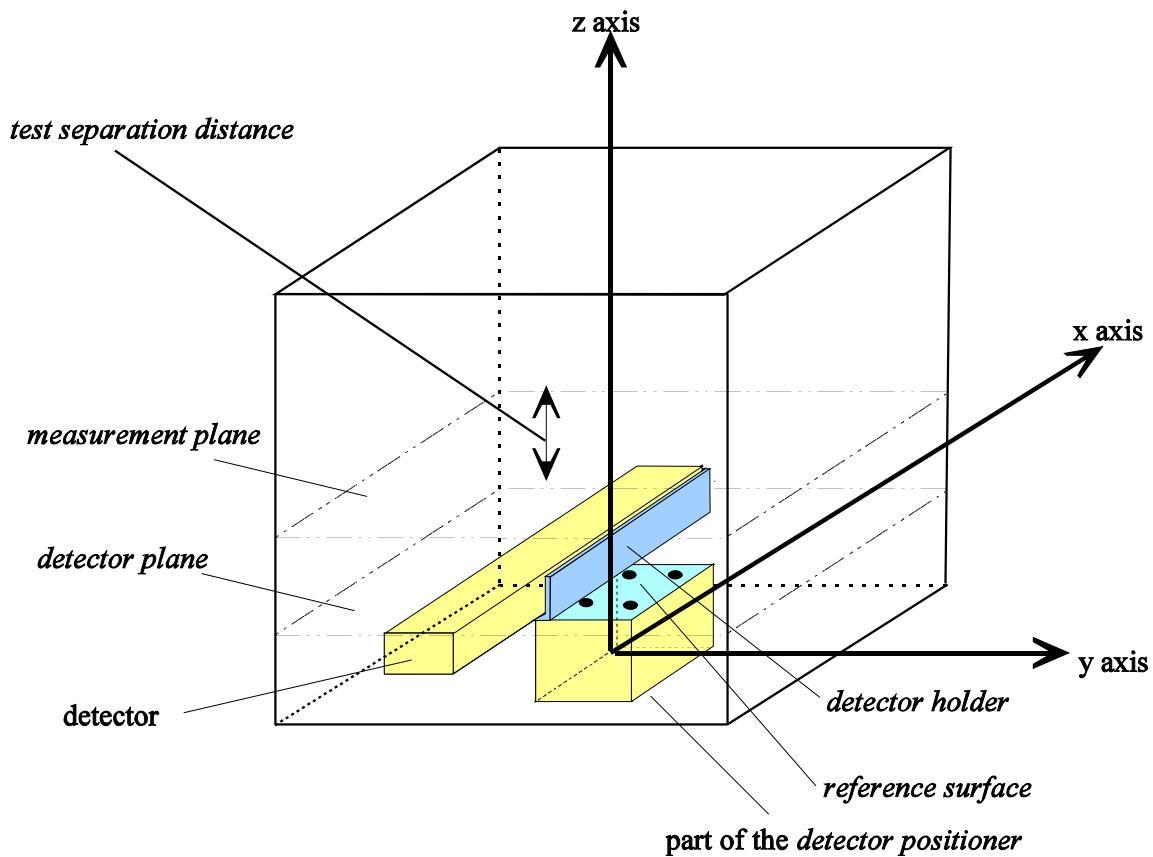

Figure 3. Diagram of measurement coordinate system showing the measurement coordinate system axes, one measurement plane, the detector plane, and the reference surface, where the detector mount, containing a detector, is unmounted

1.2.12 Reference Axis

An imaginary line that is perpendicular to the *reference surface* and is centered in the *reference surface*. See figure 4.

1.2.13 Reference Surface

The planes located on the *detector mount* and *detector positioner* that are used to attach the *detector mount* and *detector positioner*. See figure 2.

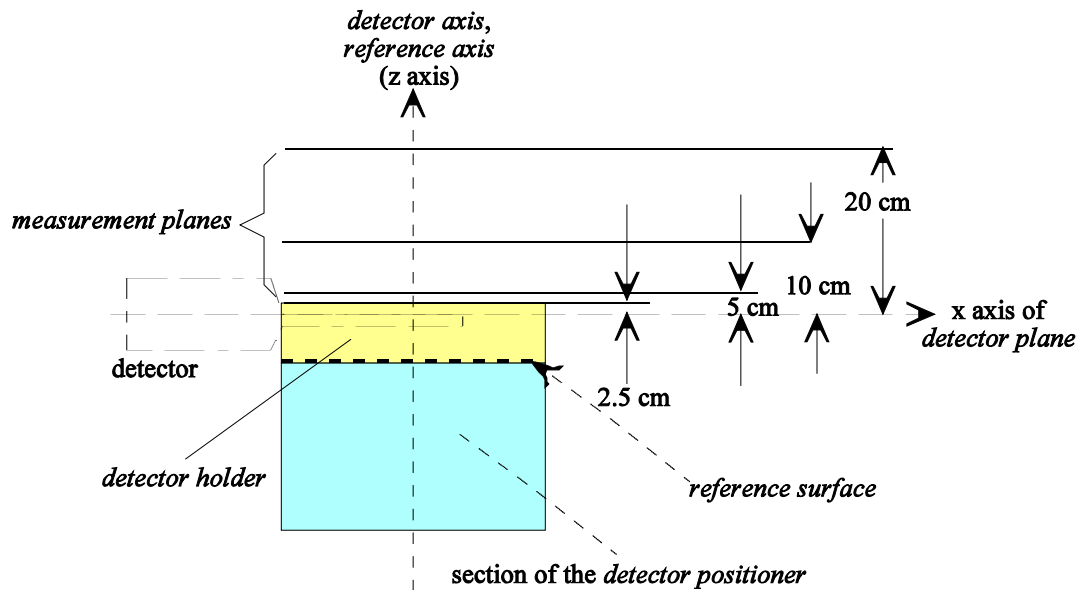

Figure 4. A schematic of the detector mount with detector in place and of the reference block where the detector mount is properly located on the detector positioner, that is, where: the z axis of the measurement coordinate system, the detector axis, and the reference axis are collinear; the detector mount and detector positioner are in contact at their reference surfaces; and the long axis of the detector is collinear with the x axis of the measurement coordinate system

1.2.14 Object Size Classes

A classification method based on the ability to detect metal objects of a minimum size. A detector may meet the requirements for one or all *object size classes*, as defined below.

1.2.14.1 Large Object Size

The ability to detect guns and large knives concealed on an individual that are constructed of either ferromagnetic or nonferromagnetic metal. Large knives are defined for this purpose as knives with blade lengths exceeding 7.5 cm (3 in).

1.2.14.2 Medium Object Size

The ability to detect small weapons and contraband items concealed on an individual that are constructed of either ferromagnetic or nonferromagnetic metal. Small weapons and contraband items are defined as any item that can be used to injure another person or to defeat security devices.

1.2.14.3 Small Object Size

The ability to detect very small hard-to-find items that are considered a threat to officer and prisoner safety or that can be used to defeat security measures concealed on an individual that are constructed of either ferromagnetic or nonferromagnetic metal.

1.2.15 Test Object

An item that is used to test the hand-held detection performance. The *test object* is an encased replica of a metallic item and this item is either a weapon, can be used as a weapon, or can be used to defeat security devices. The shape of the encasement is a parallelepiped. The encasement has up to 12 holes that allow the replica to be oriented with respect to the *measurement coordinate system*; no more than nine possible orientations are allowed, one to three orientations for each, but no more than three, unique orthogonal surfaces of the parallelepiped.

1.2.15.1 Large Object Size Test Objects

Test objects that are used to test the *large object size* detection performance of hand-held metal detectors used as weapon detectors. Mechanical drawings of the *large object size test objects* are provided in section 5.1.

1.2.15.2 Medium Object Size Test Objects

Test objects that are used to test the *medium object size* detection performance of hand-held metal detectors used as weapon detectors. Mechanical drawings of the *medium object size test objects* are provided in section 5.2.

1.2.15.3 Small Object Size Test Objects

Test objects that are used to test the *small object size* detection performance of hand-held metal detectors used as weapon detectors. Mechanical drawings of the *small object size test objects* are provided in section 5.3.

1.2.15.4 Innocuous Item Test Objects

Test objects that are used to test the discrimination performance of the *large object size* and *medium object size* hand-held metal detectors. Mechanical drawings of the *innocuous item test objects* are provided in section 5.4.

1.2.16 Test Object Axes

The three mutually orthogonal axes of the *test object* that are referenced to and have a one-to-one correspondence to the axes of the *measurement coordinate system*.

1.2.17 Test Separation Distance

The distance between the *measurement plane(s)* and the *detector plane*. The *test separation distances* are: 5 cm, 10 cm, and 20 cm. See figure 4.

1.2.18 Three-Axes Positioning System

Also known as a Cartesian robot, the *three-axes positioning system* provided three mutually orthogonal directions of linear translation. The *three-axes positioning system* is used to place the magnetic field sensor and *test objects* in the magnetic field of the detector.

2. REQUIREMENTS FOR ACCEPTANCE

The detector shall meet the requirements and specifications stated in this section. Reports shall be provided on the forms contained in section 6.

2.1 Safety Specifications and Requirements

2.1.1 Electrical

The detector shall comply with UL 1950, Second Edition, Underwriters Laboratories Standard for Information Technology Equipment, Including Electrical Business Equipment, if the potential difference between any two points within the detector is greater than 30 V rms (42.4 V peak) for alternating-currents (ac) or greater than 60 V referenced to ground for direct-currents (dc).

2.1.2 Mechanical

The detector shall not expose (1) any sharp corners or edges that can puncture, cut, or tear the skin or clothing or injure persons coming in contact with the detector, (2) external wires and cables, or (3) loose covers and cowlings. The minimum exposed radius of curvature for corners and edges shall be 2 mm (0.08 in).

2.1.3 Exposure

The level of the electromagnetic field generated by the detector shall be less than the exposure limits specified in IEEE C95.1–1991, as amended.

2.1.4 Exposure Warning Labels

A warning label that states, “This Device May Affect Personal Medical Electronic Devices,” should be permanently affixed to the detector to warn operators and persons subject to screening of potential danger of exposure to magnetic fields until such time that the Food and Drug Administration or some other competent Federal agency requires a different warning label or has determined that no such warning is necessary.

2.2 Electrical Requirements

2.2.1 Power

2.2.1.1 Battery Condition

The manufacturer shall provide a visual indicator to alert the operator of the battery condition as described in section 2.6.2.2.

2.2.1.2 Minimum Battery Life

The detector must be designed so that the battery life is at least 40 h as tested in accordance with section 3.6.

2.2.2 Burn-In

Power-on dynamic burn-in testing, at the manufacturer’s or contractor’s plant, is required in accordance with section 3.7.

2.3 Detection Performance Specifications

2.3.1 Detection Sensitivity

The *detector response* shall be measured for each appropriate *test object* positioned in the appropriate *measurement plane* for each allowed orientation of the *test object axes* with respect to the *measurement coordinate system* moving at a speed of 1.0 m/s \pm 0.05 m/s in accordance with section 3.2.3. (The appropriate *measurement planes* are the *large object size*, *medium object size*, and *small object size measurement planes* as defined in sec. 1.3.10). The *test object*, the orientation of the *test object axes* of this *test object* with respect to the *measurement coordinate system*, and the *test measurement location* of this *test object* that provide a minimum *detector response* for the appropriate *object size class* shall be recorded and specified as the “minimum detection conditions.” The *test object*, the orientation of the *test object axes* of this *test object* with respect to the *measurement coordinate system*, and the *test measurement*

location of this test object that provide a maximum *detector response* for the appropriate *object size class* shall be recorded and specified as the “maximum detection conditions.”

2.3.2 Speed

The detector shall alarm for the “minimum detection conditions” for each appropriate *object size class* as determined according to section 2.3.1 for the *test object* moving at the following speeds: 0.05 m/s \pm 0.01 m/s, 0.5 m/s \pm 0.01 m/s, 1.0 m/s \pm 0.01 m/s, 1.5 m/s \pm 0.01 m/s, and 2.0 m/s \pm 0.01 m/s as tested in accordance with section 3.2.4 and the results shall be recorded.

2.3.3 Repeatability

The detector shall alarm without failure for the “minimum detection conditions” for each appropriate *object size class* as determined according to section 2.3.1 for the *test object* moving at a speed of 1.0 m/s \pm 0.05 m/s for 50 consecutive trials under the following conditions:

- a) The delay between subsequent trials shall be no more than 60 s.
- b) There shall be no detector readjustment between trials.

The repeatability test shall be performed in accordance with section 3.2.4 and the results shall be recorded.

2.3.4 Discrimination

2.3.4.1 Large and Medium Object Size

The detector shall alarm for the “minimum detection conditions” for each appropriate *object size class* as determined according to section 2.3.1 for the *test object* moving at a speed of 1.0 m/s \pm 0.05 m/s and without detector readjustment shall not alarm for each appropriate *innocuous item test object* (listed in sec. 5.4) positioned in the appropriate *measurement plane* moving at a speed of 1.0 m/s for 50 consecutive trials without failure under the following conditions:

- a) The *test object axes* shall be oriented to give the strongest interaction between the *test object* and the detector at the point defined by the intersection of the *large object size* and *medium object size measurement planes* with the *detector axis*.
- b) The delay between subsequent trials shall be no more than 60 s.
- c) There shall be no detector readjustment between trials.
- d) Tests shall randomly alternate between *innocuous item test object* and appropriate *object size class test object*.

The discrimination test shall be performed in accordance with section 3.2.4 and the results shall be recorded.

2.3.4.2 Small Object Size

Not applicable.

2.3.5 Body Concealment

The detector shall alarm for each appropriate *test object* tested in accordance with section 3.2.5 and the results shall be recorded.

2.4 Operating Requirements

2.4.1 Operator Controls

Only those controls indicated here shall be accessible by the operator. Other controls and adjustments that affect the detector performance shall be inaccessible to the operator.

2.4.1.1 Detector Sensitivity Programming

If provided, the detector shall have a mechanically adjustable switch that provides at least 10 discrete sensitivity settings where 1 sensitivity setting corresponds to the requirements for each of the *object size classes* for which it is intended. The switch shall be located such that it is readily accessible by the operator or, upon request, to be within an enclosed area and inaccessible to the operator.

2.4.1.2 Background Null Feature On/Off Switch

If the background null feature is present, the detector shall have an on/off switch for the background null feature.

2.4.1.3 Power On/Off Switch

The detector shall have a power on/off switch.

2.4.1.4 Audio Alarm On/Off Switch

The detector shall have an on/off switch for the audio alarm.

2.4.2 Background Null Feature (optional)

If present, this feature shall allow the detector to automatically null the response to a stationary steel (AISI C1015 to C1020) plate $1\text{ m} \pm 10\text{ cm}$ by $1\text{ m} \pm 10\text{ cm}$ by $1\text{ mm} \pm 0.1\text{ mm}$ thick within $5\text{ s} \pm 1\text{ s}$ where the *detector plane* is parallel to one edge of the plate, bisects the adjacent edges of the plate, and the *detector axis* is $10\text{ cm} \pm 1\text{ cm}$ from a large surface of the

plate. In the background null state the detector shall still detect the appropriate *test objects* in the *object size class* for which it is intended.

2.4.3 Interference

The detector performance shall not be susceptible to external sources of electromagnetic and mechanical interferences as given in the following specifications.

2.4.3.1 Electromagnetic

2.4.3.1.1 Radiated Emission

The detector shall comply with FCC 47 CFR; Title 47–Telecommunications; Part 15, Radio Frequency Devices, as amended, if applicable.

2.4.3.1.2 Radiated Susceptibility

The detector shall not be affected by outside influences as tested in accordance with section 13 of American Society for Testing and Materials (ASTM) Designation F 1468–95, as amended, and as modified by the following procedure. For each test in section 13, the detector shall be placed at a distance of 1 m from the electrical influence test probe. The interference shall not cause the detector to alarm without cause or affect the equipment’s ability to detect as tested in accordance with section 3.2 and this modified procedure.

2.4.3.2 Metallic Interference

The detector shall not produce a *positive alarm indication* when operated near metal walls, as tested in accordance with section 3.5, but shall produce a *positive alarm indication* for each appropriate *test object* and its orientation providing a minimum response as determined according to section 2.3.2 for the *test object* moving at a speed of 1.0 m/s \pm 0.05 m/s in the appropriate *measurement plane* when operated near a metal wall in accordance with section 3.5.3.

2.4.4 Environmental Ranges and Conditions

The detector or all of its components and their interconnections shall meet the requirements of all of the following standards. The requirements of section 2.1 and section 2.5 shall not be affected by the tests described in this section. The requirements given in this section shall be applied appropriately for either indoor or indoor/outdoor detector models. The requirements of this section shall be exhibited by no less than the first production unit for each unique detector model and for any physical modifications to that model.

2.4.4.1 Temperature Stability and Range

2.4.4.1.1 Indoor

The detector shall operate over the ambient temperature range of at least 0 C to 43 C (32 F to 109 F) with no observable change in detection performance specifications.

2.4.4.1.2 Indoor/Outdoor

The detector shall operate over the ambient temperature range of at least -37 C to 65 C (-35 F to 149 F) with no observable change in detection performance specifications.

2.4.4.2 Relative Humidity Stability and Range

2.4.4.2.1 Indoor

The detector shall be tested in accordance with the requirements of MIL-STD-810E Method 507.3, Procedure I - Natural, as amended, with no observable change in detection performance specifications.

2.4.4.2.2 Indoor/Outdoor

The detector shall be tested in accordance with the requirements of MIL-STD-810E Method 507.3, Procedure I - Natural, as amended, with no observable change in detection performance specifications.

2.4.4.3 Salt Fog

2.4.4.3.1 Indoor

Not applicable.

2.4.4.3.2 Indoor/Outdoor

The detector shall be tested in accordance with the requirements of MIL-STD-810E Method 509.3, as amended, with no observable change in detection performance specifications.

2.4.4.4 Fungus

2.4.4.4.1 Indoor

Not applicable.

2.4.4.4.2 Indoor/Outdoor

The detector shall be tested in accordance with the requirements of MIL–STD–810E Method 508.4, as amended, with no observable change in detection performance specifications.

2.4.4.5 Rain

2.4.4.5.1 Indoor

Not applicable.

2.4.4.5.2 Indoor/Outdoor

The detector shall be tested in accordance with and meet the requirements of MIL–STD–810E Method 506.3, as amended, with no observable change in detection performance specifications.

2.4.4.6 Sand/Dust

2.4.4.6.1 Indoor

The detector shall be tested in accordance with and meet the requirements of MIL–STD–810E Method 510.3, as amended, with no observable change in detection performance specifications.

2.4.4.6.2. Indoor/Outdoor

The detector shall be tested in accordance with and meet the requirements of MIL–STD–810E Method 510.3, as amended, with no observable change in detection performance specifications.

2.4.4.7 Environmental Corrosion

2.4.4.7.1 Indoor

Not applicable.

2.4.4.7.2 Indoor/Outdoor

The detector enclosure shall meet the requirements of NEMA 250–1997, Section 3 for Enclosure Type 4, as amended, with no observable change in detection performance specifications.

2.4.4.8 Solar Radiation (Sunshine)

2.4.4.8.1 Indoor

Not applicable.

2.4.4.8.2 Indoor/Outdoor

The detector shall be tested in accordance with and meet the requirements of MIL-STD-810E Method 505.3, as amended, with no observable change in detection performance specifications.

2.5 Mechanical Specifications and Requirements

2.5.1 Dimensions and Weight

The detector should be capable of being gripped by a single hand, shall weigh less than 1 kg (2.2 lbs), and be designed to reduce operator fatigue during long-term use.

2.5.2 Durability/Ruggedness

The detector or all of its components and their interconnections shall meet the requirements of the following standards. The requirements of section 2.1 and section 2.5 shall not be affected by the tests described in this section.

2.5.2.1 Impact Resistance

2.5.2.1.1 Shock

The detector shall be tested in accordance with the requirements of IEC 68-2-27 1987, as amended, with no observable change in detection performance specifications.

2.5.2.1.2 Bump

The detector shall be tested in accordance with the requirements of IEC 68-2-29 1987, as amended, with no observable change in detection performance specifications.

2.5.2.1.3 Drop

The detector shall be tested in accordance with the requirements of IEC 68-2-31 1982, as amended, with no observable change in detection performance specifications.

2.5.2.1.4 Free Fall

The detector shall be tested in accordance with the requirements of IEC 68–2–32 1975, as amended, with no observable change in detection performance specifications.

2.5.2.1.5 Bounce

The detector shall be tested in accordance with the requirements of IEC 68–2–55 1987, as amended, with no observable change in detection performance specifications.

2.5.2.2 Pressure Resistance

The detector shall be capable of withstanding the force of 600 N (135 lb) over any 1 cm x 1 cm (0.4 in x 0.4 in) area on the detector for a sustained period of 1 min.

2.6 Functional Requirements

2.6.1 Audible Alarms

All audible indicators (other than an earphone) shall produce an alarm-state sound pressure level $0.8 \text{ m} \pm 0.08 \text{ m}$ from the detector of $85 \text{ dB}_{\text{SPL}} \pm 5 \text{ dB}_{\text{SPL}}$ measured in accordance with section 3.3.2. For status indicators, the audible alarm shall be a two-state audible alarm and the two states shall be active (alarm state) and inactive (nonalarm state). For metal object warning, the audible alarm shall be a frequency-proportional audible alarm or, optionally, a two-state audible alarm.

2.6.1.1 Earphone Jack, Optional

If an earphone jack is supplied with the hand-held metal detector, the earphone shall disable the audible *alarm indicator* when the earphone is plugged into the earphone jack.

2.6.1.2 Frequency-Proportional Alarm Indicator for Metal Object Detection

The detector shall have a proportional audible *alarm indication* with an audio frequency output that is continuously proportional to the size, proximity, orientation, and material of a metal object in the region around the detector. The frequency-proportional *alarm indication* shall have a quiescent state frequency drift rate, measured in accordance with section 3.3, of not more than 5 Hz/s. The *proportional alarm indication* shall vary by at least 2000 Hz within the frequency range of 500 Hz to 4000 Hz for objects varying in size from the smallest *test objects* of the appropriate *object size class* to the metal test panel described in section 3.5.1 and shall not vary in amplitude over the operating frequency range by more than 0.5 dB.

2.6.1.3 Two-State Alarm Indicator for Metal Object Detection

The detector shall have, as an option to section 2.6.1.2.1, a two-state audible *alarm indication* to alert the operator about the presence of a metal object. The two-state alarm indicator shall produce no sound in the nonalarm state and shall produce an audio frequency alarm within the range of 500 Hz to 4000 Hz with a -3dB frequency bandwidth of less than 1 % of the selected operating frequency and a frequency drift of less than 5 Hz/s and less than 1 % of the selected operating frequency over any 2-h period.

2.6.2 Visual Indicators

Any visible *alarm indication* shall be readily perceptible when tested in accordance with section 3.3.4. The visual *alarm indicators* shall be a two-state visual alarm and the two states shall be active (illuminating) and inactive (nonilluminating).

2.6.2.1 Metal Object Detection

The detector shall have a visual alarm indicating the presence of a metal object in *the target space*. The alarm state for the metal-object-detection visual *alarm indicator* shall be active (illuminating) and the nonalarm state shall be inactive (nonilluminating). The metal-object-detection visual *alarm indicator* shall be distinct from any other visual *alarm indicators*.

2.6.2.2 Power Condition

The detector shall have a visual alarm indicating the condition of the battery and shall be activated if the battery condition drops to a level that can cause a degradation of the detection performance required by this standard. The power-condition visual *alarm indicator* shall be active (illuminating) if the battery condition is acceptable and shall be inactive (nonilluminating) if there exists a battery condition problem. The power-condition visual *alarm indicator* shall be distinct from any other visual *alarm indicators*.

2.6.2.3 System Status

The detector shall have a visible alarm indicating the operational state of the emitter, emitter circuitry, detector, and detector circuitry and shall be activated if changes in the operational state of these components of the detector can cause a degradation of the detection performance required by this standard. The system status visual *alarm indicator* shall be inactive (nonilluminating) if the system status is acceptable and shall be active (illuminating) if there exists a system status problem. The system status visual *alarm indicator* shall be distinct from any other visual *alarm indicators*.

2.6.3 Detection Signal Output Connector

The detector shall have a coaxial connector that provides an analog output of the detector signal and this detector signal shall be extracted immediately after the detection circuitry on which an alarm indication is based but before the circuitry that executes the alarm. The outer conductor of the connector shall provide signal ground or return.

2.6.4 Interchangeability

Any given model of detector manufactured by the same manufacturer shall have interchangeable parts.

2.7 Detector Mount

The manufacturer shall provide with each detector, if requested, a holder for mounting the detector on the *reference surface* (see fig. 5) of the measurement system (see fig. 2 and 3). The *detector mount* shall comply with the Safety Specifications and Requirements of section 2.1.2 and shall meet the following specifications:

- a) Relative permeability = $1. \pm 0.001$.
- b) Electrical conductivity $< 10^{-8}$ Siemens/m.
- c) Mass 2 kg (4.5 lbs).
- d) Surface flatness ± 0.5 mm (0.041 in).
- e) Firmly hold the detector.
- f) Mate with the *reference surface*.
- g) Fastener holes align with each of the four 1/4-20 fastener holes of the *reference surface* (see fig. 2, 3, and 5).
- h) Hold the detector so that the *detector axis* and *reference axis* are collinear.
- i) Hold the detector so that the longest axis of the detector that is parallel to the detector plane is collinear with the x axis of the measurement coordinate system.
- j) Hold the detector so that the *detector plane* is $10 \text{ cm} \pm 0.1 \text{ cm}$ from the *reference surface*.
- k) The top surface should be located less than 2.5 cm from the detector plane. If the detector is of such shape and geometry that access to the measurement plane at a separation distance of 2.5 cm is not possible, then the test separation distance for the closest possible measurement plane shall be reported.
- l) Hold the detector such that no part of the detector is above the *measurement plane* at a *test separation distance* of 2.5 cm.

2.8 Quality Control and Assurance

The manufacturer shall meet the requirements of ISO 9001:1994(E), as amended.

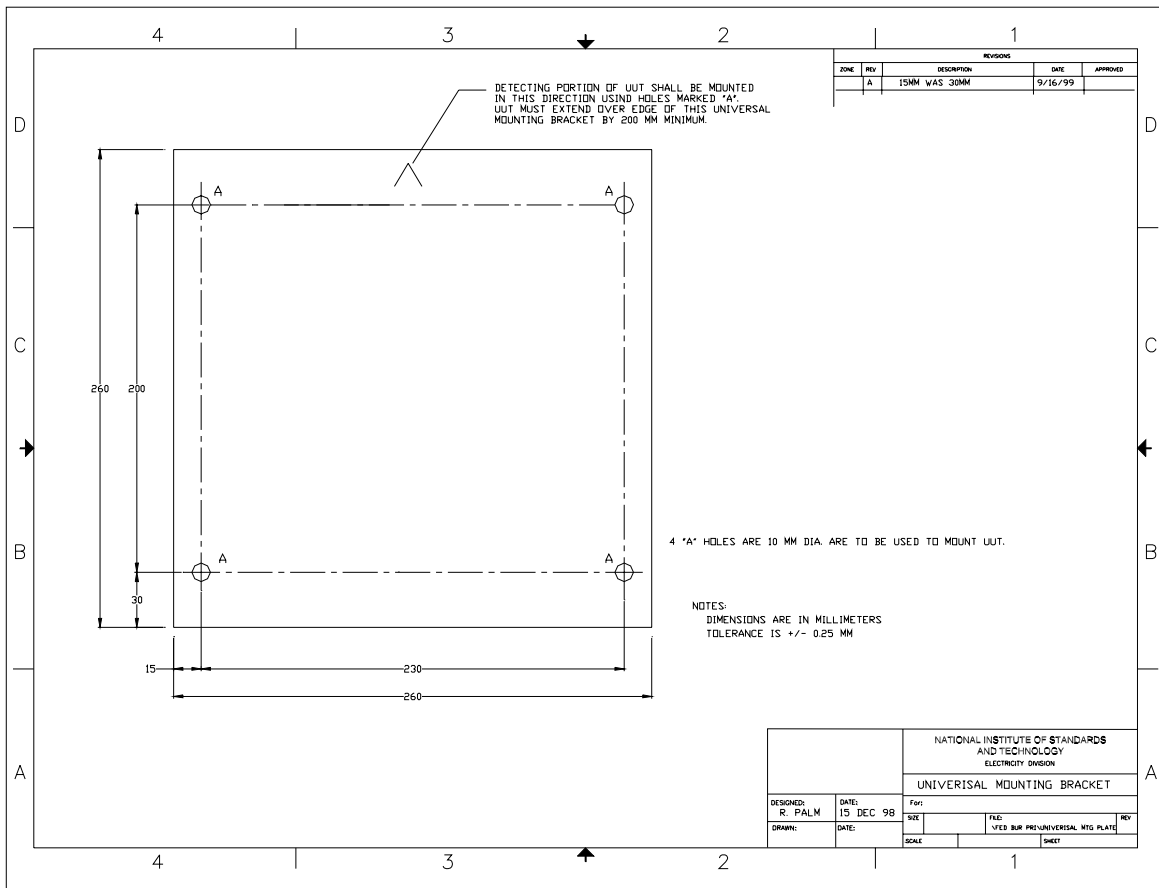

Figure 5. Mechanical drawing of reference surface

2.9 Documentation

The manufacturer shall provide the following list of deliverable items with each detector, unless otherwise indicated.

2.9.1 Operating Instructions

An operator's manual shall be supplied by the manufacturer or distributor with each detector.

2.9.1.1 Discussion of Operation

The manufacturer shall provide a manual designed to ensure that the operators will have the knowledge and skill to understand the purpose, detection principles, and detection capabilities of

the detector. The operator should also be able to identify the main components of the detector, the features of the controls, and be aware of the electromagnetic emissions of the detector.

2.9.1.2 Block Diagram of Major Internal Components

The manufacturer shall provide a drawing of the configuration and specifications of the detector (block diagram) to assist in the training, troubleshooting, and servicing of the detector.

2.9.2 Operator Training Instructions and Videotape or CD-ROM

A training package shall be supplied that will provide operators with the information necessary to acquire the technical and operational skills required to conduct effective screening with the detector. The training package shall include an audio/visual videotape or CD-ROM as well as an operator's manual. For additional guidance in formulating the operator training package, review ASTM Designation F 1532-94, "Standard Guide for Qualification, Selection, Training, Utilization, and Supervision of Security Screening Personnel," published by the American Society for Testing and Materials; or "A Users' Guide for Hand-Held and Walk-Through Metal Weapon Detectors," published by the National Institute of Justice. The manufacturer shall have demonstrated the effectiveness of the training material when 50 % of the test group receiving the training understands the operation of the detector and passes a written test and can operate the detector successfully as judged by performing the field tests of section 4 without supervision, where the test group consists of at least 10 people with only a high school education.

2.9.3 Technical Manual

A technical manual that contains all of the information that could be required by a technician to troubleshoot, maintain, and repair the equipment to the component level shall be provided, upon request.

2.9.4 Technical Training Manual and Videotape or CD-ROM

A self-study training package shall be provided for use by site maintenance technicians, upon request. The training package must consist of an audio/visual videotape or CD-ROM as well as a technical manual that provides detailed explanations of circuit theory and maintenance procedures.

2.9.5 Technical Specifications

The manufacturer shall provide a detailed listing of all relevant specifications of the detector. This checklist shall include at a minimum:

- a) Detector *object size class* (as classified in sec. 1.3).

- b) Mechanical drawings of the detector with dimensions in metric units.
- c) Mass of the detector.
- d) Battery type and quantity.
- e) Maximum magnetic field strength that can be found on the detector surface.
- f) If applicable, operating frequency and, if applicable, modulation parameters.
- g) If applicable, pulse repetition rate, pulse duration, and pulse transition duration.
- h) Operating ambient temperature range.

2.9.6 Certification of Inspection and Conformance

The manufacturer shall provide a certification of all mandatory tests, a record of the test results for the detector, and the identity the organization(s) conducting the tests.

2.9.7 Certification of Test Procedures

The manufacturer shall provide a detailed step-by-step description of the test plan and procedures. The manufacturer shall provide a certification with each delivered detector showing that a set of m detectors of the same type and model as the delivered detector were selected using simple random sampling methods and tested without replacement (where $m = \frac{0.1Mk_M}{0.1k_M + 0.01M}$,

M is the number of available detectors and k_M is the coverage factor for the 99 % confidence interval, see Table B.1 of B.N. Taylor and C.E. Kuyatt, “NIST Technical Note 1297, Guidelines for Evaluating and Expressing the Uncertainty of NIST Measurement Results,” U.S. Government Printing Office, Washington, DC, 1994), and met the requirements of this Standard. The manufacturer shall provide the test results of this randomly selected set of same type and model detectors.

2.9.8 Suggested Maintenance Schedule

The manufacturer shall provide a preventive maintenance schedule and a detailed list of the technical skills, computer hardware, and software tools required.

2.9.9 Installation Instructions

The manufacturer shall provide instructions for battery installation and specify the type and quantity of batteries required.

2.9.10 Report Sheets

The manufacturer shall complete the report sheets provided in section 6 and according to the formats described therein.

3. PERFORMANCE TESTING PROCEDURES

The detector shall meet the detection performance requirements for each *object size class* in which it is required to operate. The detection performance shall be evaluated by the test methods described in this section. The manufacturer shall record and provide the test results on the report sheets provided in section 6 of this randomly selected set of same type and model detectors.

3.1 General Test Conditions

3.1.1 Test Location

The distance between any metal object other than a *test object* and the closest part of the detector shall be greater than 0.8 m (31 in).

3.1.2 Environment

At the time of the tests, the ambient temperature shall be between -37 °C and 49 °C (-35 °F and 120 °F); the relative humidity shall be between 10 % and 80 %.

3.1.3 Preparations

New batteries of the type listed in the operator's manual shall be installed at the beginning of the tests and as instructed in any test method. Any setup or calibration adjustments specified in the operator's manual shall be performed if required.

3.2 Detection Performance Tests

3.2.1 Object Size Classes

If the detector can be adjusted to provide an *alarm indication* for more than one *object size class*, the detection performance test shall be performed for each *object size class*. The detection performance shall be evaluated by the test methods described in this section. The distinction in testing between the different *object size classes* is the difference in the *test separation distance* of the *measurement plane* and the *test objects*.

3.2.2 Equipment

3.2.2.1 Test Objects

Test objects shall be as described in section 5.

3.2.2.2 Three-Axes Positioning System

The *three-axes positioning system* shall meet the following requirements:

- a) At least 0.5 m (1.65 ft) displacement in each of three orthogonal axes.
- b) Microprocessor controlled.
- c) At least 2 m/s speed for the y axis motion.

3.2.2.3 Magnetic Field Sensor

The magnetic field probe shall have a frequency response bandwidth at least five times greater than the bandwidth of the emitted magnetic field, provide a rms voltage output, and have sensing dimensions less than or equal to 4 cm x 4 cm x 4 cm.

3.2.2.4 Voltmeter

The ac voltmeter shall have a bandwidth at least five times greater than the bandwidth of the emitted magnetic field, allow computer control and data retrieval, and have a variable gain input with at least 10-bit resolution full scale.

3.2.2.5 Detector Positioner

The *detector positioner* is a nonmagnetic, nonconductive device that provides a surface on which to securely attach the *detector mount* and that places the detector at a fixed location in the *measurement coordinate system* relative to the *three-axis positioning system*. A diagram of the *detector holder* showing the *reference axis*, *reference surface*, and x, y, and z *measurement coordinate system* axes is given in figure 4. A detailed mechanical drawing of the *reference surface* is provided in figure 5.

3.2.2.6 Computer Controller

The computer controller shall have installed and operational all necessary hardware and software for providing instrument control and data acquisition.

3.2.3 Detection Sensitivity

3.2.3.1 Initial Procedures

Ensure that the voltmeter and positioning system are connected to the computer controller and that the hand-held metal detector signal output connector (see sec. 2.6.3) is connected to the voltmeter. Turn on the voltmeter, computer controller, and positioning system and verify proper operation of the measurement system. Ensure that the hand-held metal detector is securely held by the *detector mount* and fasten the *detector mount* to the reference block. Attach the *test object*

with the proper orientation to the positioning system. Turn on the hand-held metal detector and ensure that its output is functioning properly by noting a change in the voltmeter reading as a metal object is brought near the hand-held metal detector. Ensure that the *test object* does not hit any objects while in motion.

3.2.3.2 Performing the Measurement

Set the computer program to perform an x-y scan over the *measurement plane* at the specified speed. Set the x-axis position to $-20\text{ cm} \pm 0.1\text{ cm}$ relative to the *detector axis* and scan the y axis. Acquire the signal present at the detector signal output connector (see sec. 2.6.3) using the voltmeter and record this measurement as the y-axis is in motion. Increment the x-axis position by $1\text{ cm} \pm 0.1\text{ cm}$ and perform a y-axis scan. Repeat the x-axis increment and y-axis scan until the x-axis position is approximately $20\text{ cm} \pm 0.1\text{ cm}$. Record the detection sensitivity during the y-axis scan such that data is provided every $1\text{ cm} \pm 0.1\text{ cm}$. The center for the y-axis scans shall be the *detector axis* and the scans shall each be $40\text{ cm} \pm 0.1\text{ cm}$ long.

3.2.4 Speed

3.2.4.1 Initial Procedures

Ensure that the voltmeter and *three-axes positioning system* are connected to the computer controller and that the hand-held metal detector signal output connector (see sec. 2.6.3) is connected to the voltmeter. Turn on the voltmeter, computer controller, and *three-axes positioning system* and verify proper operation of the measurement system. Ensure that the hand-held metal detector is securely held by the *detector mount* and fasten the *detector mount* to the *detector holder*. Attach the *test object* with the proper orientation to the *three-axes positioning system*. Turn on the hand-held metal detector and ensure that the detector output is functioning properly by noting a change in the voltmeter reading as a metal object is brought near the hand-held metal detector. Ensure that the *test object* does not hit any objects while in motion.

3.2.4.2 Performing the Measurement

Set the position program to perform a y-axis scan passing through the *detector axis* in the appropriate *measurement plane* at the specified speed. Note any audible alarm. The center of the y-axis scan shall be the *detector axis* in the appropriate *measurement plane* and the y-axis scan shall be $40\text{ cm} \pm 0.1\text{ cm}$ long.

3.2.5 Body Concealment

3.2.5.1 Initial Procedures

Select a person, the tester, to hold the appropriate *test object*. Turn on the voltmeter and the hand-held metal detector and ensure that hand-held metal detector output is functioning properly

by noting a change in the voltmeter reading as a metal object is brought near the hand-held metal detector. Ensure that the tester does not cause an alarm indication from the hand-held metal detector when the hand-held metal detector is positioned at a displacement of $5 \text{ cm} \pm 1 \text{ cm}$ from the side of the arm of the tester and at about armpit height.

3.2.5.2 Performing the Measurement

Place the *test object* under the armpit of the tester. Position the hand-held metal detector at a displacement of $5 \text{ cm} \pm 1 \text{ cm}$ from the side of the arm of the tester, at a plane about 0.5 m in front of the tester, and at about armpit height. Maintaining the height and the lateral (sideways) displacement of the hand-held metal detector with respect to the tester, move the hand-held metal detector to a plane approximately 0.5 m in back of the tester within 1 s. Note any alarm indication.

3.3 Alarm Indication Tests

3.3.1 Equipment

3.3.1.1 Sound Level Meter

The sound pressure level meter shall comply with ANSI S1.4, 1971, “Specifications for General Purpose Sound Level Meters” for type 3, A-weighting, reference pressure $20 \text{ } \mu\text{Pa}$.

3.3.1.2 Audio Frequency Measurement System

The system for measuring the fundamental audio frequency of an audible alarm indication shall be capable of measuring a frequency difference with an accuracy of 1 Hz and be capable of providing a new measurement within 4 s after a change in frequency.

3.3.1.3 Illumination Meter

The illumination meter shall be capable of measuring light levels of 25 lm/m^2 and $10,000 \text{ lm/m}^2$ with an error of not more than 10 %. The integrated spectral response shall be within 10 % of the Commission Internationale de l'Eclairage (CIE, the International Commission on Illumination) photopic curve.

3.3.2 Sound Pressure Level Test

Perform the test in an anechoic chamber or at an outdoor location, at least 6 m from any large object, where the ambient sound pressure level at the time of the test is not more than $53 \text{ dB}_{\text{SPL}}$. Position the sound pressure level meter microphone $0.80 \text{ m} \pm 0.02 \text{ m}$ from the detector. Measure the sound pressure level with the detector power applied and the *alarm indicator* in the nonalarm

state. Then position the appropriate test object at a *test separation distance* of approximately 5 cm to produce an alarm, and again measure the sound pressure level.

3.3.3 Frequency Stability Test

After the detector has been off for at least 5 min, turn the detector on and complete any operator adjustments specified in the operator's manual within 10 s. At $15\text{ s} \pm 1\text{ s}$ again at $45\text{ s} \pm 1\text{ s}$ after the detector has been turned on, measure the frequency. Compute the average frequency drift rate by taking the difference between the measured frequencies and dividing by 30 s. Perform the procedure three more times and compute the mean of the average frequency drift rates.

3.3.4 Visible Alarm Indicator Test

Position the detector with its alarm indicator $0.80\text{ m} \pm 0.02\text{ m}$ from the eyes, at a test site where the ambient illumination is $10,000\text{ lm/m}^2 \pm 1000\text{ lm/m}^2$. After waiting at least 3 min to allow for eye accommodation, turn on the detector and move a metal object near the detector to cause an alarm. Observe the indication. Repeat the test at a test site where the ambient illumination is $25\text{ lm/m}^2 \pm 2.5\text{ lm/m}^2$.

3.4 Test for Operation Near a Metal Wall

3.4.1 Metal Test Panel

The metal test panel shall be cold-finished sheet carbon steel AISI C1015 to C1020, $1\text{ m} \pm 0.1\text{ m}$ by $1\text{ m} \pm 0.1\text{ m}$ by $0.75\text{ mm} \pm 0.13\text{ mm}$ thick. The panel shall be mounted or supported in a manner which keeps the panel flat.

3.4.2 Procedure

Position the detector with its *detector plane* parallel to and $1\text{ m} \pm 0.1\text{ m}$ from the plane of the test panel and with the *detector axis* centered with respect to the test panel. Turn on the detector and adjust its controls as specified in the operator's manual. Note the *alarm indicator* response. Then change the separation distance to $0.6\text{ m} \pm 0.1\text{ m}$ within 1 s and immediately note the new *alarm indicator* response.

3.5 Battery Life Test

Install in the detector new or fully charged batteries of the type specified by the manufacturer. Turn the detector on and leave it on for a continuous 40 h period. At least once each 8 h interval, the detector shall be tested in accordance with sections 2.3.3, 2.3.4, and, if applicable, section 2.3.5. The test results shall be recorded and a report shall be provided.

3.6 Burn-In Test

The burn-in test is to be performed for a minimum of 160 consecutive hours, with the last 40 h failure free. The burn-in test shall include, at a minimum:

3.6.1 Cycling of the Equipment

Once each working shift (8 h), the detector shall be cycled on and off 10 times within 20 s and immediately (within 60 s) tested in accordance with section 2.3.4.

3.6.2 Performance Evaluation

Once each working shift (8 h), the detector shall be tested according to section 2.3.3 and section 2.3.5.

4. FIELD TESTING PROCEDURES

4.1 Large Object Size

The detector shall be turned on and placed approximately 10 cm (4 in) from the *innocuous item test objects* described in section 5.4 to assure that the objects are not detected. The detector shall then be placed approximately 10 cm (4 in) from the *large object size test objects* described in section 5.1 to assure that the objects are properly detected. Repeat this test three times at pass-by speeds ranging from approximately 0.5 m/s to approximately 1.5 m/s to assure proper detector performance.

4.2 Medium Object Size

The detector shall be turned on and placed approximately 10 cm (4 in) from the *small object size test objects* described in section 5.3 to assure that the objects are not detected. The detector shall then be placed approximately 10 cm (4 in) from the *medium object size test objects* described in section 5.2 to assure that the objects are properly detected. Repeat this test three times at pass-by speeds ranging from approximately 0.5 m/s to approximately 1.5 m/s to assure proper detector performance.

4.3 Small Object Size

The detector shall be turned on and placed approximately 40 cm (16 in) from the *small object size test objects* described in section 5.4 to assure that the objects are not detected. The detector should then be placed approximately 5 cm (2 in) from the *small object size test objects* to assure that the objects are properly detected. Repeat this test three times at pass-by speeds ranging from approximately 0.5 m/s to approximately 1.5 m/s to assure proper detector performance.

5. TEST OBJECTS DESCRIPTION

This section contains mechanical drawings of the *test objects*. The *test objects* are encased replicas of threat items. All dimensions in the mechanical drawings are given in units of millimeters (mm).

5.1 Large Object Size Test Objects

The following mechanical drawings are replicas of the *large object size* items that are considered a threat to officer, prisoner, inmate, and public safety. These *large object size* threat items are a knife and a handgun.

5.1.1 Knife

This section contains mechanical drawings of the replica of a knife, a *large object size test object*, that are arranged in the following order: the mechanical drawing of the replica of the knife and the location of the replica within the encasement.

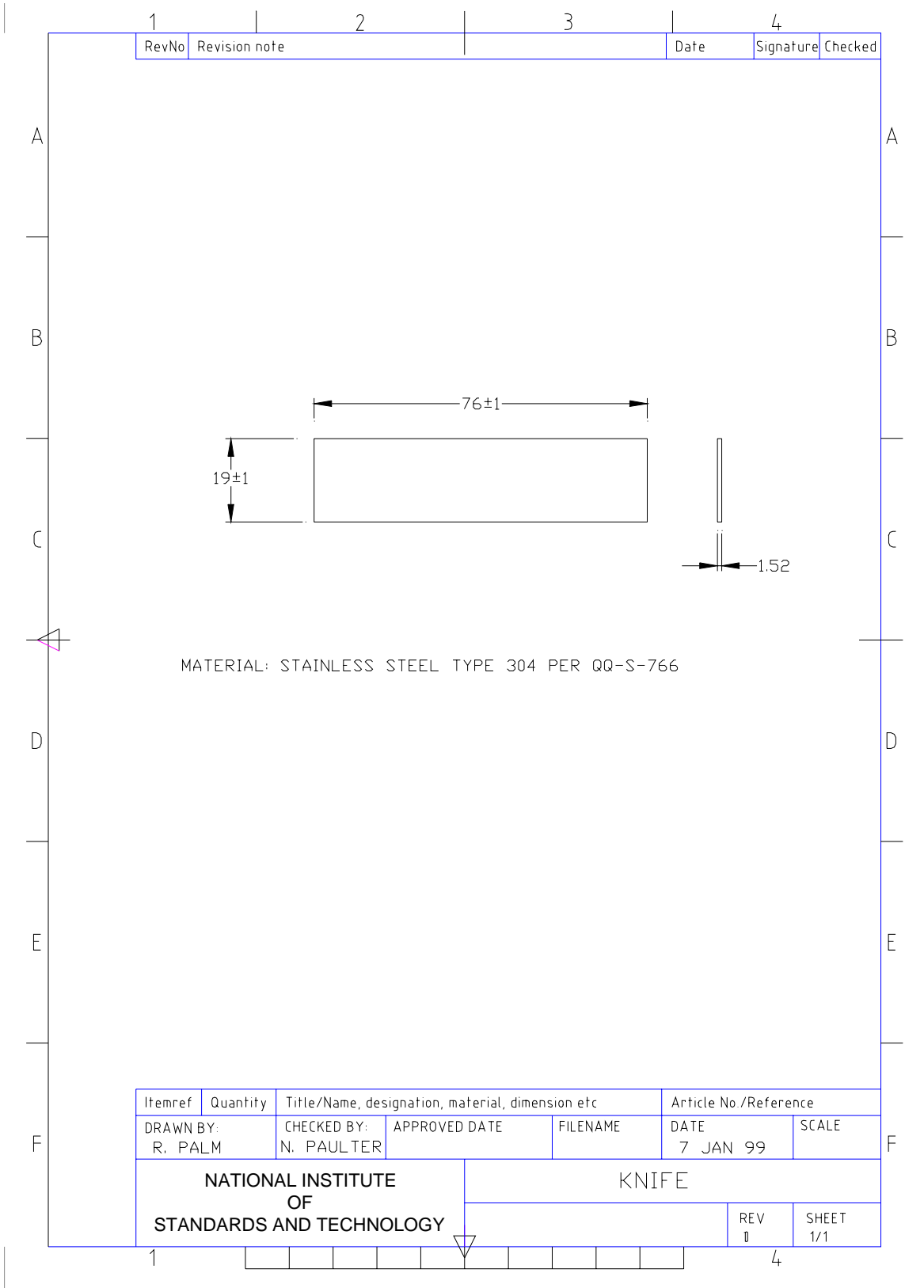

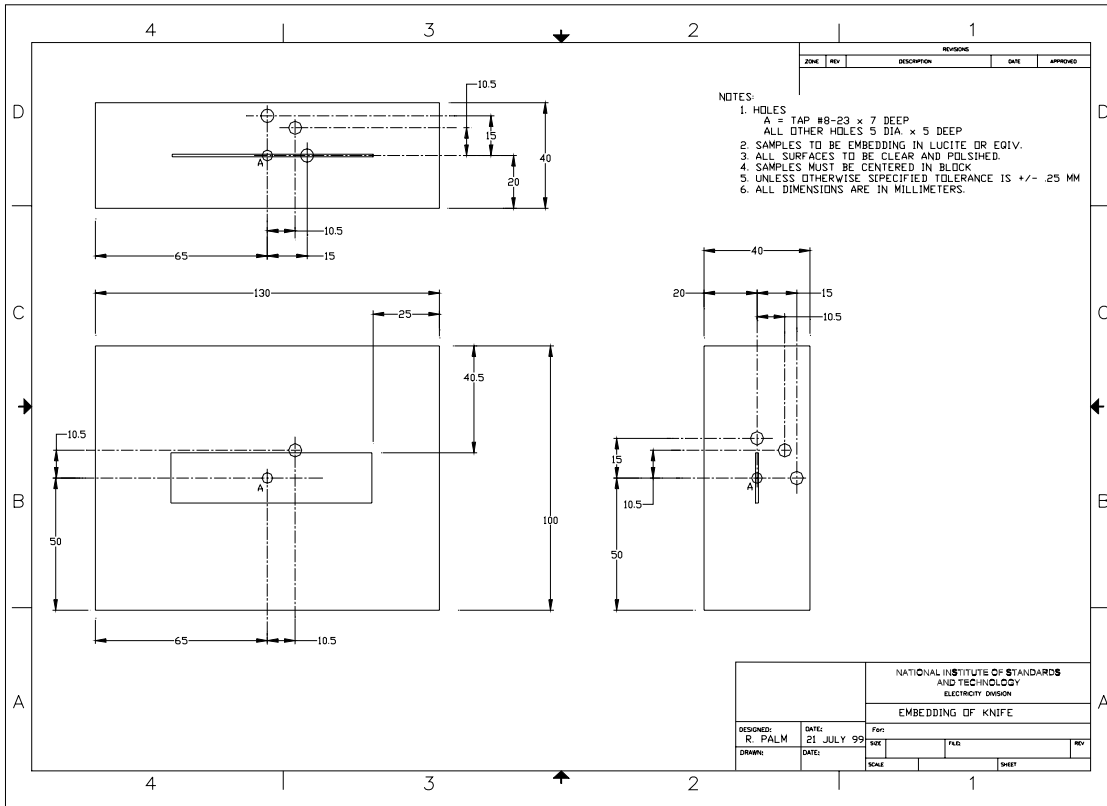

5.1.2 Handgun

This section contains mechanical drawings of the replica of a handgun, a *large object size test object*, that are arranged in the following order: the mechanical drawing of the replica of the handgun and the location of the replica within the encasement.

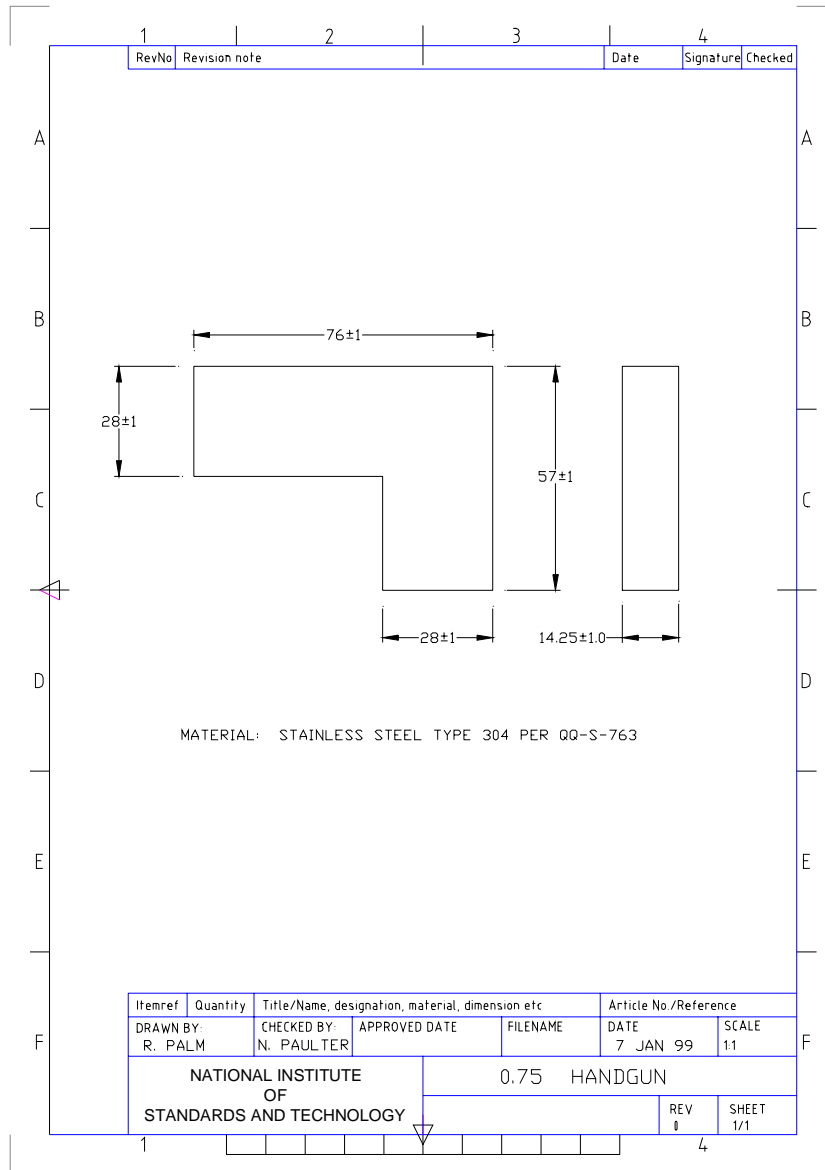

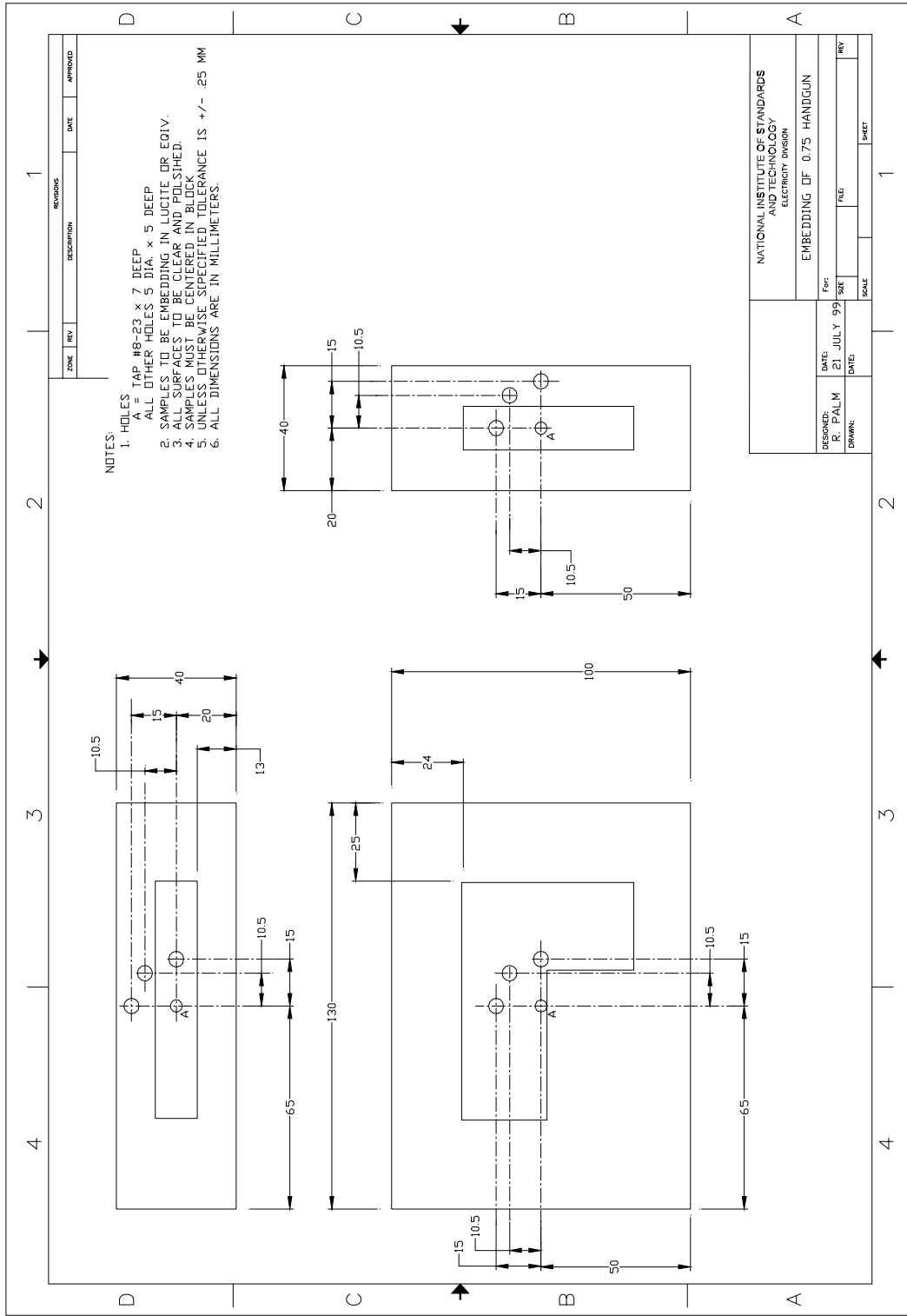

5.2 Medium Object Size Test Objects

The following mechanical drawings are replicas of the *medium object size* items that are considered a threat to officer and prisoner safety and that can be used to defeat security measures. These items are replicas of a handcuff key and a 22 Long Rifle cartridge.

5.2.1 Handcuff Key

This section contains mechanical drawings of the replica of a handcuff key, a *medium object size test object*, that are arranged in the following order: the mechanical drawing of the replica of the handcuff key and the location of the replica within the encasement.

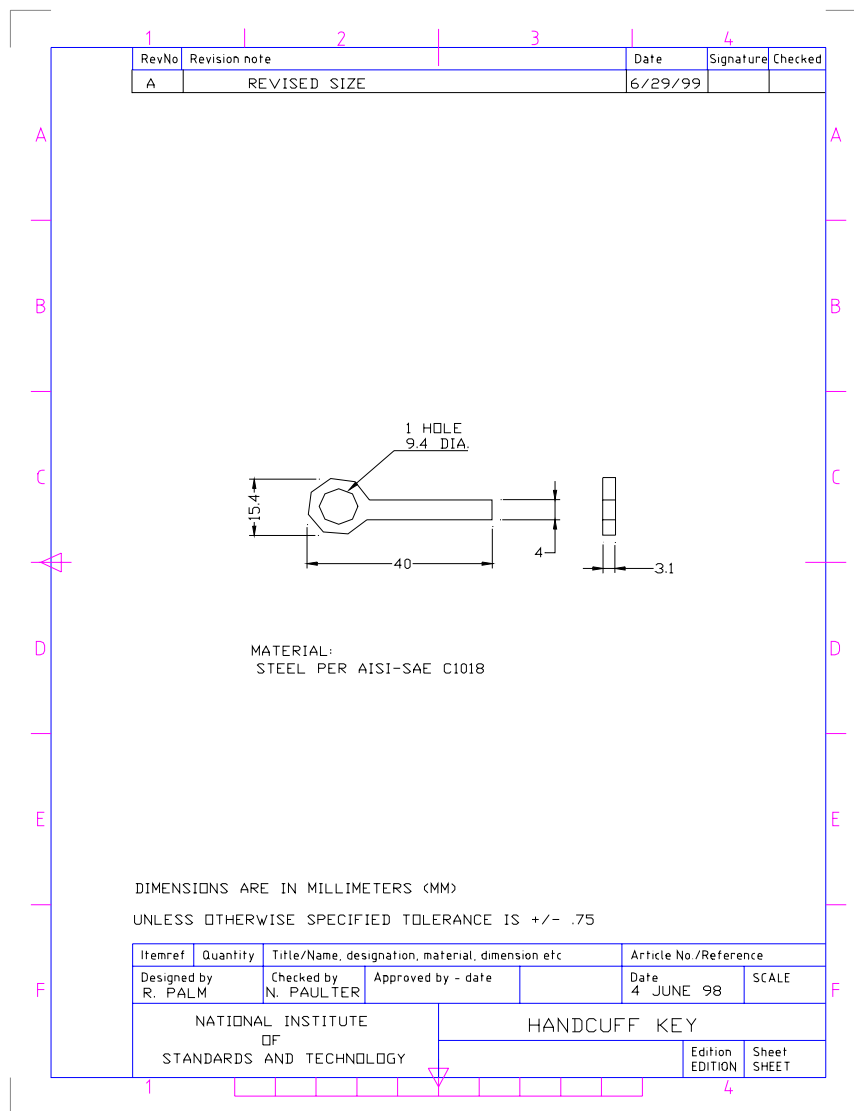

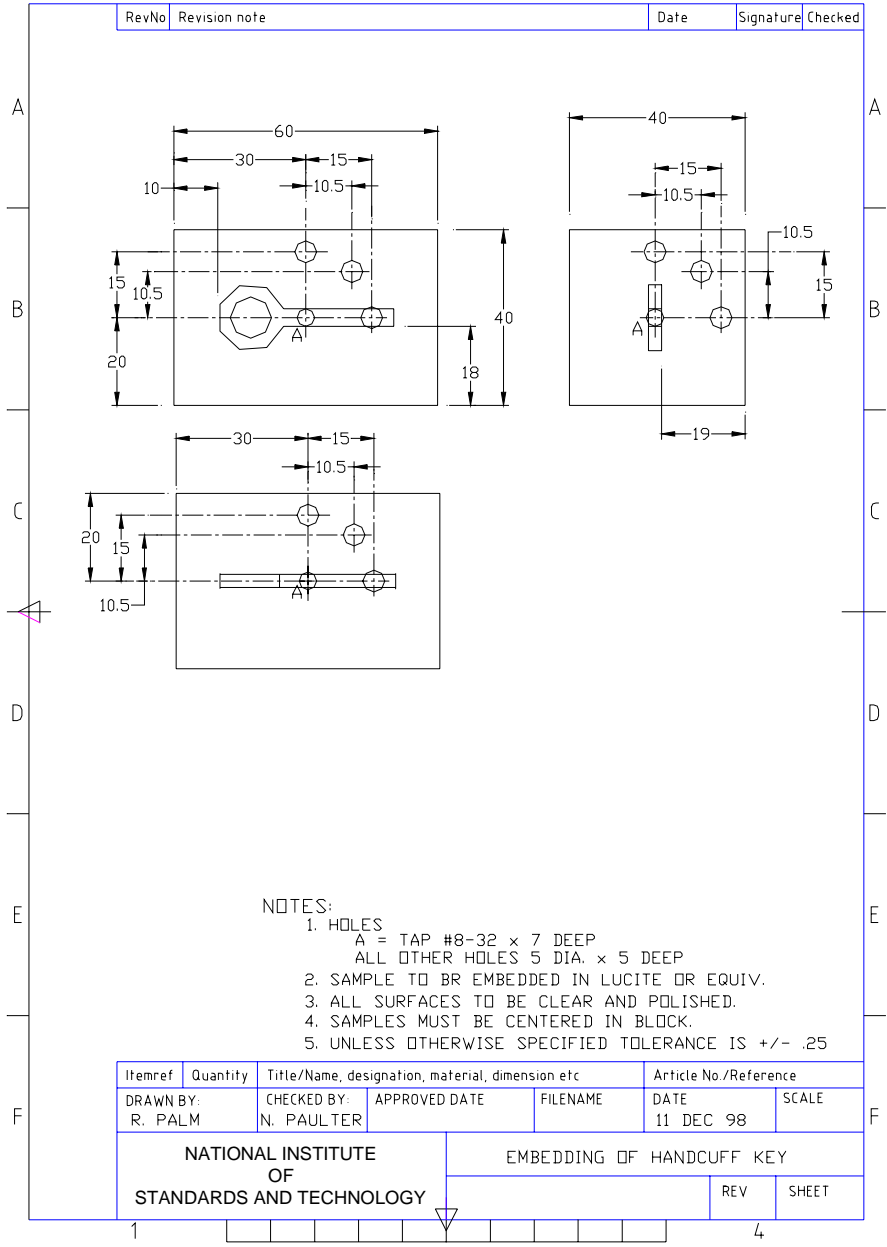

5.2.2 Firearm Cartridge, 22 Long Rifle

This section contains mechanical drawings of the replica of a firearm cartridge, a *medium object size test object*, that are arranged in the following order: the mechanical drawing of the cartridge assembly, the mechanical drawing of the bullet portion of the replica, the mechanical drawing of the case portion of the replica, and the location of the replica within the encasement.

1	2	3	4	5
RevNo	Revision note		Date	Signature
				Checked

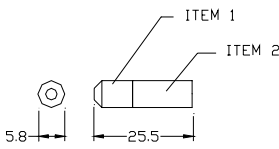

	BULLET	1	CASING	1
PART	ITEM 1 DRAWING NAME	QTY	ITEM 2 DRAWING NAME	QTY

DIMENSIONS ARE IN MILLIMETERS (MM)
UNLESS OTHERWISE SPECIFIED TOLERANCE IS +/- .75

Itemref	Quantity	Title/Name, designation, material, dimension etc	Article No./Reference
DESIGNED_BY R. PALM	CHECKED_BY N. PAULTER	APPROVED_BY_DATE	DATE 4 JUNE 1998
NATIONAL INSTITUTE OF STANDARDS AND TECHNOLOGY		SMALL CALIBER ROUND	
		Edition EDITION	Sheet SHEET

RevNo	Revision note	Date	Signature	Checked
A	REVISED SIZE	6/29/99		

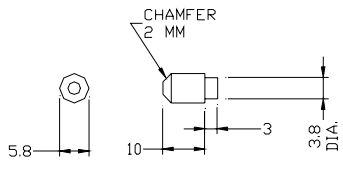

MATERIAL LEAD PER ANSI/ASTM B29-79

DIMENSIONS ARE IN MILLIMETERS (MM)
UNLESS OTHERWISE SPECIFIED TOLERANCE IS +/- .25

Itemref	Quantity	Title/Name, designation, material, dimension etc		Article No./Reference	
Designed by R. PALM	Checked by N. PAULTER	Approved by - date	FILENAME	DATE 4 JUNE 98	SCALE
NATIONAL INSTITUTE OF STANDARDS AND TECHNOLOGY		BULLET		Edition	Sheet

RevNo	Revision note	Date	Signature	Checked
A	REVISED SIZE	6/29/99		

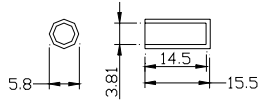

MATERIAL: BRASS 1/2 HARD COMPOSITION #22 ALLOY C36000

DIMENSIONS ARE IN MILLIMETERS (MM)
UNLESS OTHERWISE SPECIFIED TOLERANCE IS +/- .25

Itemref	Quantity	Title/Name, designation, material, dimension etc	Article No./Reference		
DESIGNED_BY R. PALM	CHECKED_BY N. PAULTER	APPROVED_BY_DATE	DATE 4 JUNE 98	SCALE	
NATIONAL INSTITUTE OF STANDARDS AND TECHNOLOGY			CASING		
			Edition EDITION	Sheet SHEET	

5.3 Small Object Size Test Objects

5.3.1 Pen Refill

This section contains mechanical drawings of the replica of a pen refill, a *small object size test object*, that are arranged in the following order: the mechanical drawing of the replica of the pen refill, and the location of the replica within the encasement.

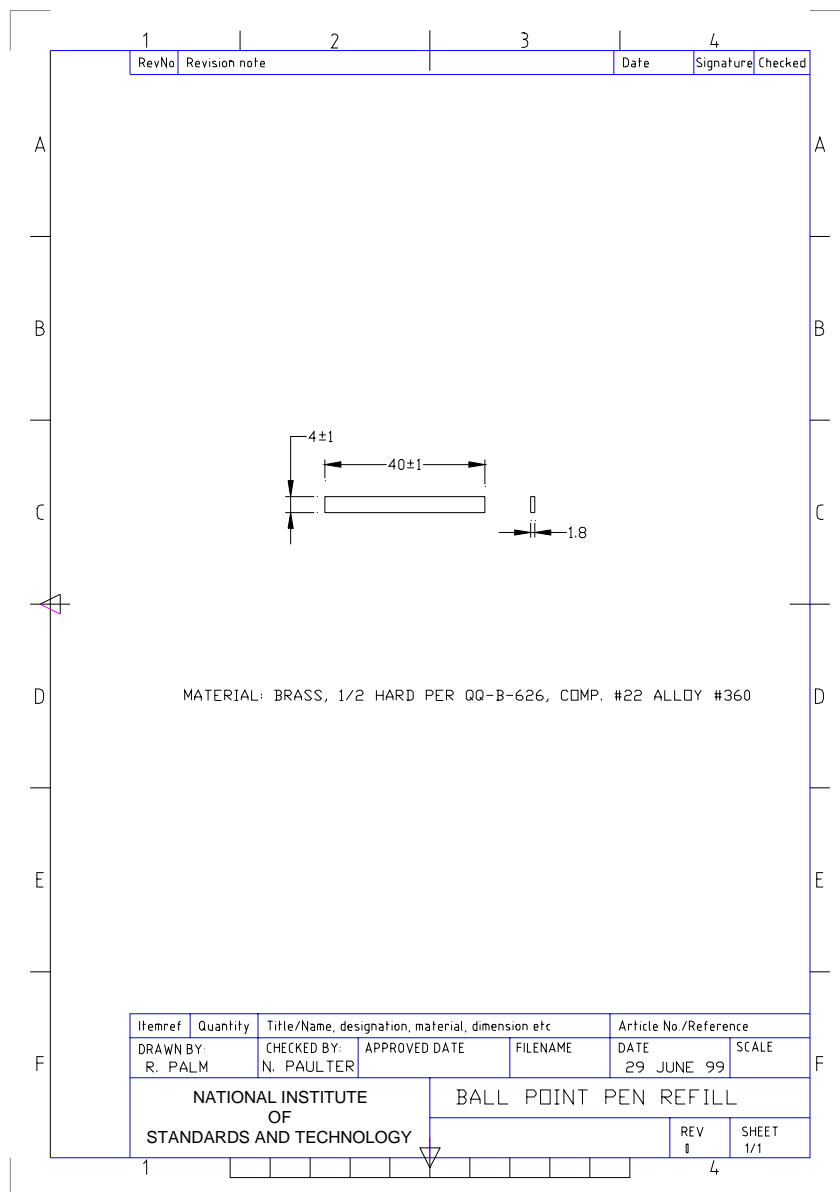

11

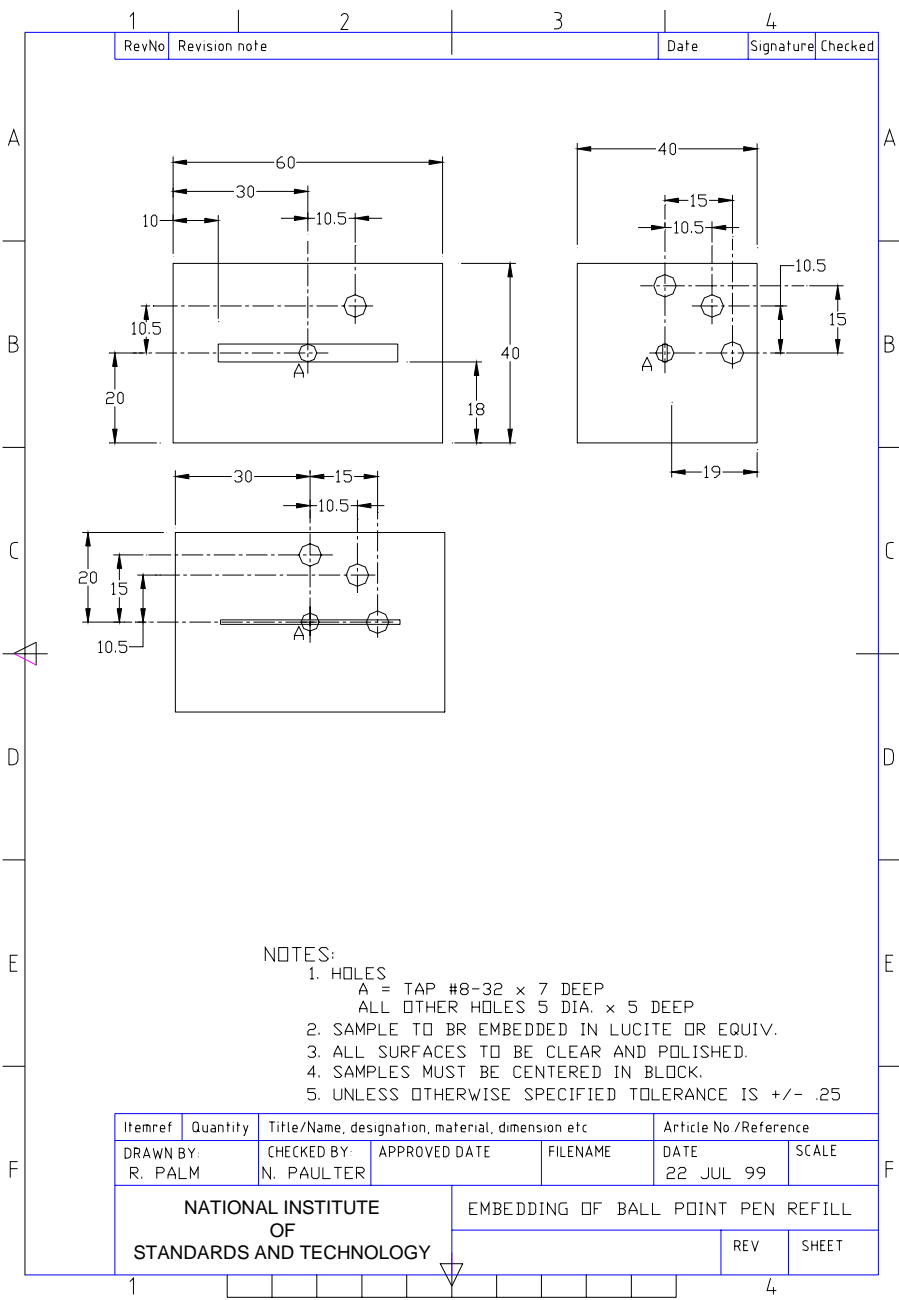

5.3.2 Razor Blade, Disposable Razor

This section contains mechanical drawings of the replica of a disposable razor blade, a *small object size test object*, that are arranged in the following order: the mechanical drawing of the replica of the razor blade, and the location of the replica within the encasement.

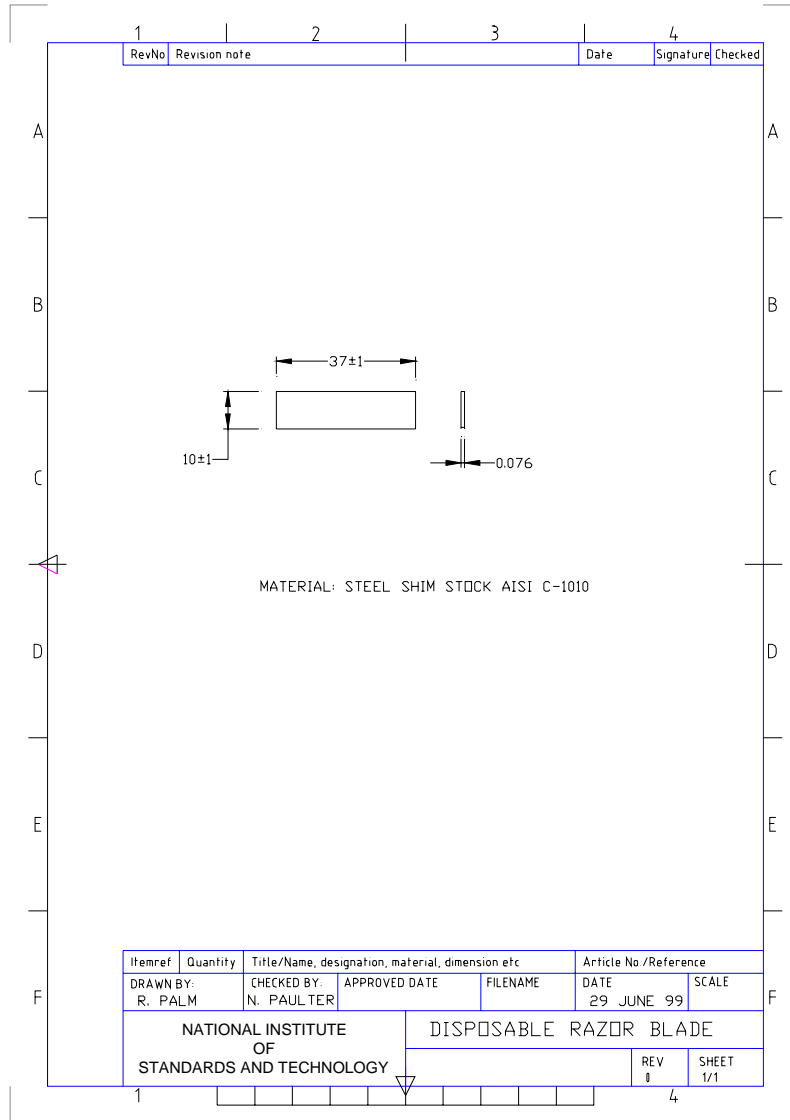

11

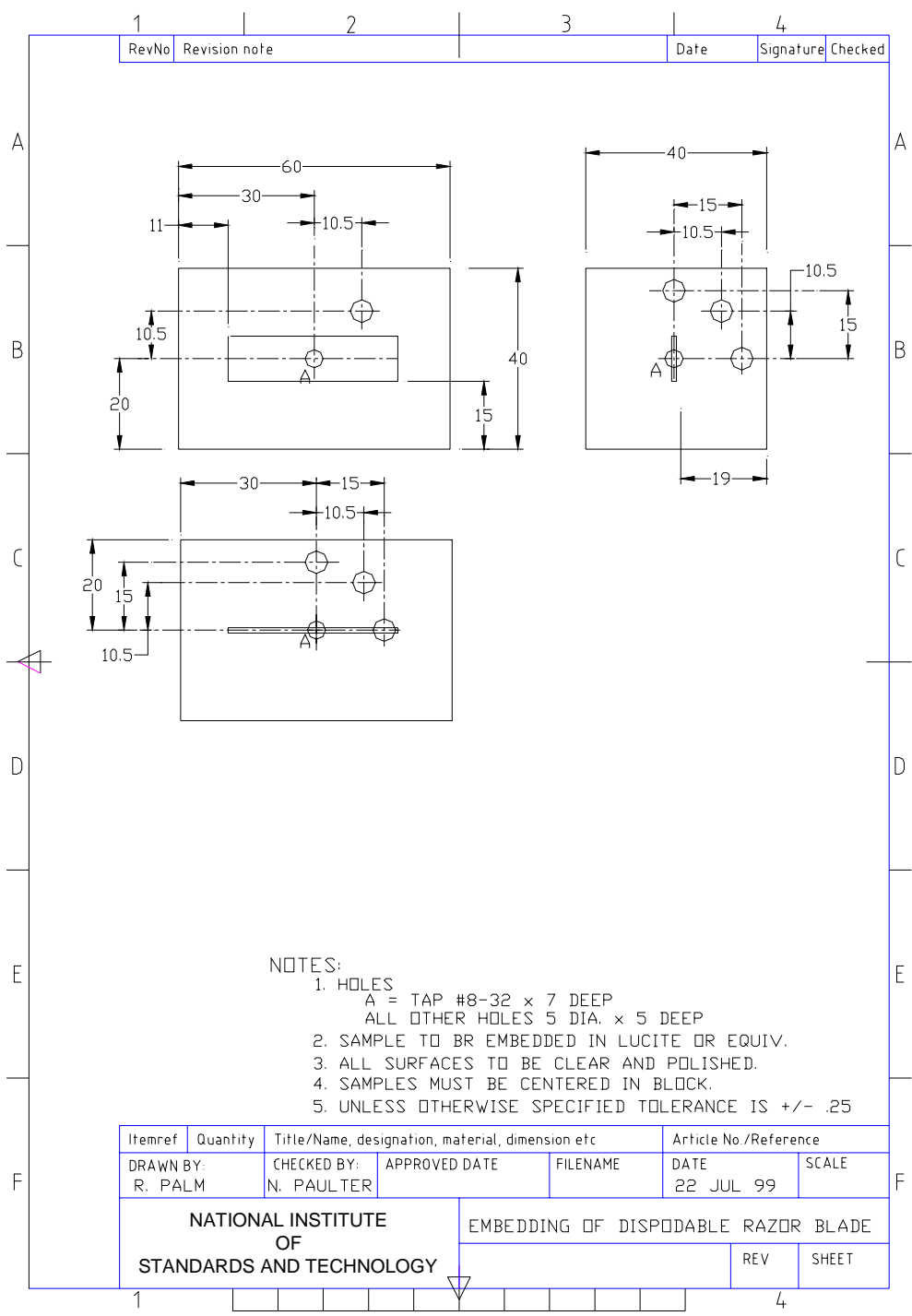

5.3.3 Hypodermic Needle, Disposable Syringe (optional)

A mechanical drawing is not included because this is an optional *small object size test object*. It is suggested that the actual object be used for this optional *small object size test object*. This optional *test object* should be the stainless steel hypodermic needle with ferrule typically found on disposable insulin syringes.

5.4 Innocuous Item Test Objects

5.4.1 Large Object Size

The *innocuous item test object* is a scaled replica of the knife, a *large object size test object*. All dimension of the *innocuous item test object* shall be 0.75 of the dimensions of the *large object size test object*.

5.4.1.1 Reduced Scale Knife

This section contains mechanical drawings of the 0.75 scaled replica of the knife (see sec. 5.1), an *innocuous item test object*, that are arranged in the following order: the mechanical drawing of the replica of the 0.75 scaled replica of the knife, and the location of the scaled replica within the encasement.

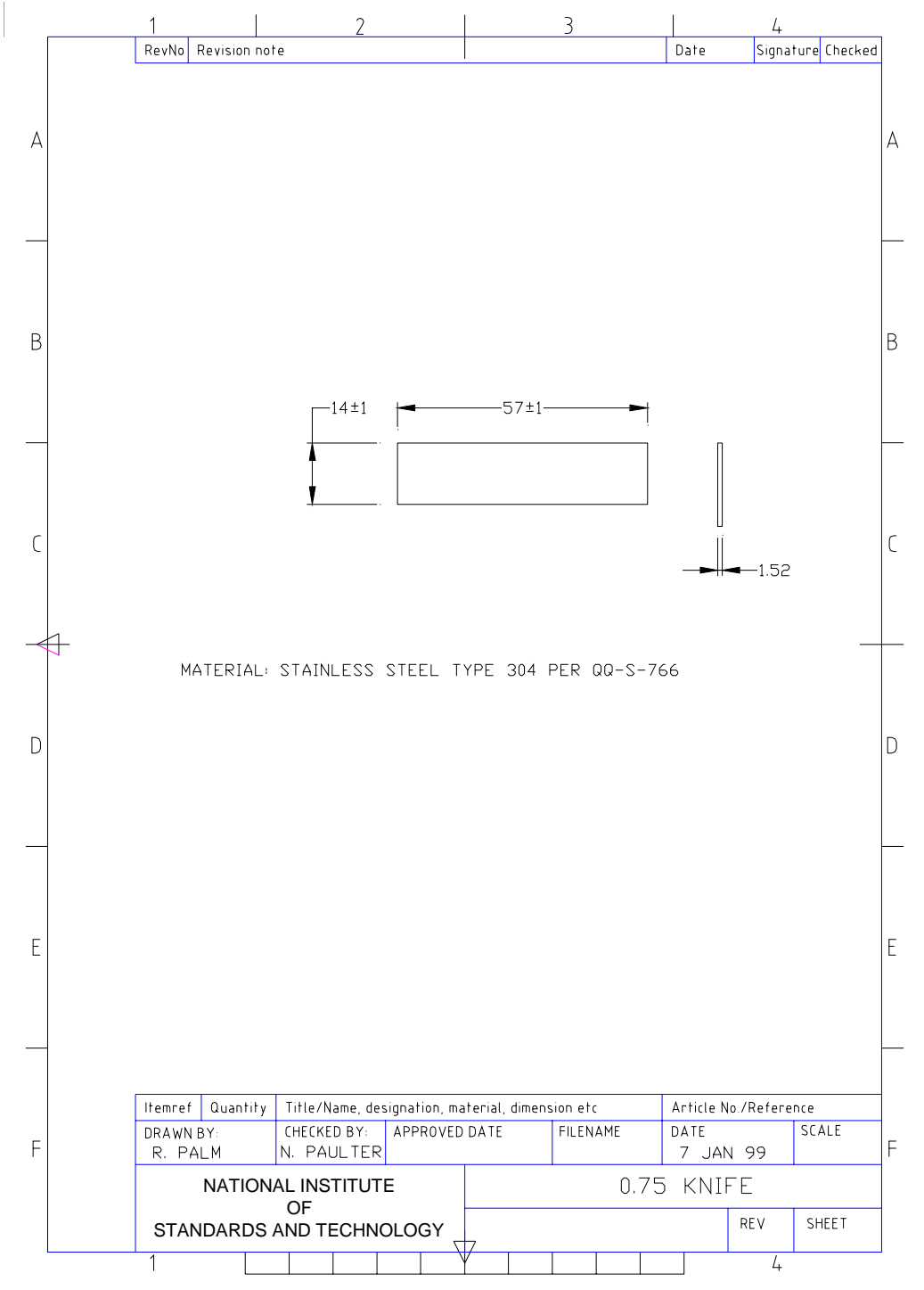

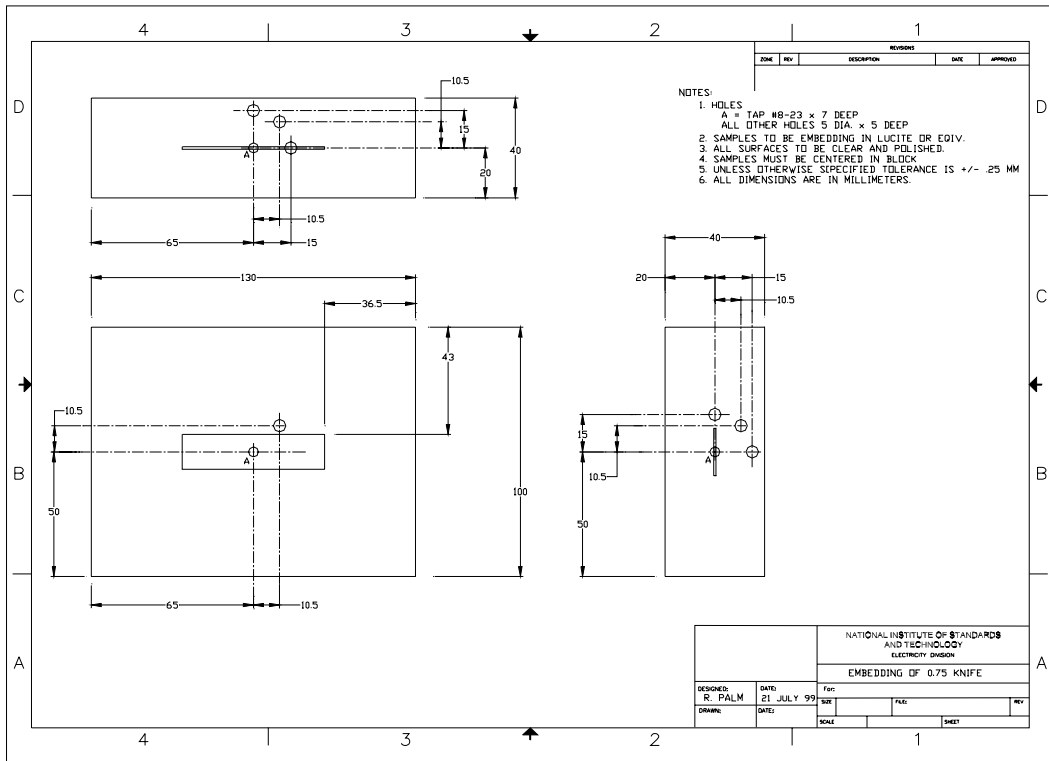

5.4.2 Medium Object Size

The *innocuous item test object* is a replica of the pen refill, a *small object size test object*.

5.4.2.1. Pen Refill

See description in section 5.3.1.

6. REPORT SHEETS

Report sheets are provided on the following pages, including instructions for reporting any data electronically.

6.1 Requirements for Acceptance Report Sheet

Manufacturer:

Model Number:

Usage (Indoor or Indoor/Outdoor):

Classification (Large and/or Medium Object Size):

	Pass/ Fail	Yes/ No	Explanation for failure or lack of compliance
2.1 Safety Specifications and Requirements			
2.1.1 Electrical			
2.1.2 Mechanical			
2.1.3 Exposure			
2.1.4 Warning Labels			
2.2 Electrical Requirements			
2.2.1 Power			
2.2.1.1 Battery Condition			
2.2.1.2 Minimum Battery Life			
2.2.2 Burn-In			
2.3 Detection Performance Specifications			
2.3.1 Detection Sensitivity ¹			
2.3.2 Speed ¹			
2.3.3 Repeatability ¹			
2.3.4 Discrimination			
2.3.4.1 Large Object Size			
2.3.4.2 Medium Object Size ¹			
2.3.5 Body Concealment			
2.4 Operating Requirements			
2.4.1 Background Null Feature (optional)			
2.4.2 Operator Controls			
2.4.2.1 Detector Sensitivity Programming (optional)			
2.4.2.2 On/Off Switch for background null feature (optional)			
2.4.2.3 Power On/Off Switch			

¹Additional Report Sheets required.

	Pass/ Fail	Yes/ No	Explanation for failure or lack of compliance
2.4.1.4 Audio Alarm On/Off Switch			
2.4.3 Interference			
2.4.3.1 Electromagnetic			
2.4.3.1.1 Radiated Emission			
2.4.3.1.1 Radiated Susceptibility			
2.4.3.2 Mechanical			
2.4.4 Environmental Ranges and Conditions			
2.4.4.1 Temperature Stability and Range			
2.4.4.2 Relative Humidity Stability and Range			
2.4.4.3 Salt Fog			
2.4.4.4 Fungus			
2.4.4.5 Rain			
2.4.4.6 Sand/Dust			
2.4.4.7 Environmental Corrosion			
2.4.4.8 Solar Radiation (Sunshine)			
2.5 Mechanical Specifications and Requirements			
2.5.1 Dimensions and Weight			
2.5.2 Durability/Ruggedness			
2.5.2.1 Impact Resistance			
2.5.2.1.1 Shock			
2.5.2.1.2 Bump			
2.5.2.1.3 Drop			
2.5.2.1.4 Free Fall			
2.5.2.1.5 Bounce			
2.5.2.2 Pressure Resistance			
2.6 Functional Requirements			
2.6.1 Audible Alarms			
2.6.1.1 Earphone Jack (optional)			
2.6.1.2.1 Frequency-Proportional Alarm Indicator, Metal Object Detection			
2.6.1.3 Two-State Alarm Indicator			
2.6.1.3.1 Metal Object Detection (optional)			

	Pass/ Fail	Yes/ No	Explanation for failure or lack of compliance
2.6.1.3.2 Low Power Condition			
2.6.2 Visual Indicators			
2.6.2.1 Metal Object Detection			
2.6.2.2 Power Condition			
2.6.2.3 System Status			
2.6.3 Detection Signal Output Connector			
2.6.4 Interchangeability			
2.7 Detector Mount			
2.8 Quality Control and Assurance			
2.9 Documentation			
2.9.1 Operating Instructions			
2.9.1.1 Discussion of Operation			
2.9.1.2 Block Diagram of Major Internal			
2.9.2 Operator Training Instructions and Videotape			
2.9.3 Technical Manual			
2.9.4 Technical Training Manual and Videotape or			
2.9.5 Technical Specifications			
2.9.6 Certification of Inspection and Conformance			
2.9.7 Certification of Test Procedures			
2.9.8 Suggested Maintenance Schedule			
2.9.9 Installation Instructions			
2.9.10 Report Sheets			

6.2 Detection Sensitivity Test Report Sheet

The test data shall be reported in a table as shown below. All length/displacement units shall be in centimeters and all sensitivity values in either amperes for an output signal current or volts for an output signal voltage. There shall be a unique record for each test object for each of its possible unique orientations. Measurement uncertainties shall be provided.

Detector model name and number:

Object size classification :

Test object:

Test object orientation:

Date of measurement:

x-axis location of y-scan (cm, relative to <i>detector axis</i>) [uncertainty, in cm]	peak signal amplitude (units) [uncertainty, in units]	average signal amplitude (units) [uncertainty, in units]
-1.0 [± 0.1]	P_{-1} [± $u_{P,-1}$]	A_{-1} [± $u_{A,-1}$]
0.0 [± 0.1]	P_0 [± $u_{P,0}$]	A_0 [± $u_{A,0}$]
1.0 [± 0.1]	P_1 [± $u_{P,1}$]	A_1 [± $u_{A,1}$]

6.3 Speed Test Report Sheet

The test data shall be reported in a table as shown below.

Detector model name and number:

Object size classification:

Test object:

Test object orientation:

Date of measurement:

SPEED (m/s)	ALARM INDICATION	
	YES	NO
0.05		
0.50		
1.00		
1.50		
2.00		

6.4 Repeatability Test Report Sheet

Detector model name and number:

Object size classification:

Test object:

Test object orientation:

Date of measurement:

TRIAL	ALARM INDICATION		TRIAL	ALARM INDICATION	
	YES	NO		YES	NO
1			26		
2			27		
3			28		
4			29		
5			30		
6			31		
7			32		
8			33		
9			34		
10			35		
11			36		
12			37		
13			38		
14			39		
15			40		
16			41		
17			42		
18			43		
19			44		
20			45		
21			46		
22			47		
23			48		
24			49		
25			50		

6.5 Discrimination Test Report Sheet

Detector model name and number:

Object size classification:

Test object:

Test object orientation:

Date of measurement:

TRIAL	ALARM INDICATION		TRIAL	ALARM INDICATION	
	YES	NO		YES	NO
1			26		
2			27		
3			28		
4			29		
5			30		
6			31		
7			32		
8			33		
9			34		
10			35		
11			36		
12			37		
13			38		
14			39		
15			40		
16			41		
17			42		
18			43		
19			44		
20			45		
21			46		
22			47		
23			48		
24			49		
25			50		

7. REFERENCES

The following normative documents contain provisions, which through reference in this text, constitute provisions of this Standards Publication. By reference herein these publications are adopted, in whole or in part, as indicated.

ACGIH-0302 (1996), American Conference of Governmental Industrial Hygienists, *Documentation of the Threshold Limit Values, Sub-Radio Frequency (30 kHz and below) Magnetic Fields*.

ANSI S1.4, 1971, American National Standards Institute, *Specifications for General Purpose Sound Level Meters*.

ASTM Designation F 1468-95, Section 13, American Society for Testing and Materials, *Standard Practice for Evaluation of Metallic Weapons Detectors for Controlled Access Search and Screening, Section 13, Procedure for Testing for Outside Influences: Electrical*.

IEC 68-2-27 1987, International Electrotechnical Commission, *Basic Environmental Testing Procedures, Part 2: Tests - Test Ea and Guidance: Shock*.

IEC 68-2-29 1987, International Electrotechnical Commission, *Basic Environmental Testing Procedures, Part 2: Tests - Test Eb and Guidance: Bump*.

IEC 68-2-31 1982, International Electrotechnical Commission, *Basic Environmental Testing Procedures, Part 2: Tests - Test Ec: Drop and Topple, Primarily for Equipment-type Specimens*.

IEC 68-2-32 1975, International Electrotechnical Commission, *Basic Environmental Testing Procedures, Part 2: Tests - Test Ed: Free Fall*.

IEC 68-2-55 1987, International Electrotechnical Commission, *Basic Environmental Testing Procedures, Part 2: Tests - Test Ee and Guidance: Bounce*.

IEEE C95.1-1991, Institute of Electrical and Electronic Engineers, *Standard for Safety Levels with Respect to Human Exposure to Radio Frequency Electromagnetic Fields, 3 kHz to 300 GHz*.

ISO 9001:1994(E), International Organization for Standardization 9001, *Quality systems - Model for Quality Assurance in Design, Development, Production, Installation and Servicing*.

FCC 47 CFR Part 15 (1996), Federal Communications Commission, *Code of Federal Regulations; Title 47-Telecommunications; Part 15, Radio Frequency Devices*.

MIL–STD–810E Method 505.3, Military Standard, *Test Method Standard for Environmental Engineering Considerations and Laboratory Tests, Method 505.3, Solar Radiation (Sunshine)*.

MIL–STD–810E Method 506.3, Military Standard, *Test Method Standard for Environmental Engineering Considerations and Laboratory Tests, Method 506.3, Rain*.

MIL–STD–810E Method 507.3, Military Standard, *Test Method Standard for Environmental Engineering Considerations and Laboratory Tests, Method 507.3, Humidity, Procedure 1 - Natural*.

MIL–STD–810E Method 508.4, Military Standard, *Test Method Standard for Environmental Engineering Considerations and Laboratory Tests, Method 508.4, Fungus*.

MIL–STD–810E Method 509.3, Military Standard, *Test Method Standard for Environmental Engineering Considerations and Laboratory Tests, Method 509.3, Salt Fog*.

MIL–STD–810E Method 510.3, Military Standard, *Test Method Standard for Environmental Engineering Considerations and Laboratory Tests, Method 510.3, Sand and Dust*.

NEMA 250–1997, National Electrical Manufacturers Association Standards Publication 250–1997, *Enclosures for Electrical Equipment (1000 Volts Maximum), Section 3 for Enclosure Type 4*.

NILECJ–STD–0602.00, National Institute of Law Enforcement and Criminal Justice, *Hand-Held Metal Detectors for Use in Weapons Detection*.

UL 1950, Second Edition, Underwriters Laboratories, *Standard for Information Technology Equipment, Including Electrical Business Equipment*.