



DE LOREAN MOTOR COMPANY

SERVICE BULLETIN

NUMBER ST-33-12/81

CATEGORY: TECHNICAL
ATTENTION: ALL DMC DEALERS/SERVICE MANAGERS
SUBJECT: WATER LEAKS - BODY

Water leaks into the interior of the vehicle body may be difficult to diagnose, and the following main points must be considered when a water leak occurs.

Does the leak occur with the vehicle in motion or standing still?

With the vehicle in motion, a water leak in the interior may be related to a much lower or distant entry point on the exterior due to the fact that a lower air pressure may exist in the interior rather than the exterior of the vehicle and equalized airflow may transport water to distant exit points in the interior. Splash water from the wheels may have an outside entry on the underside of the vehicle. Water leaks that occur with the vehicle standing still usually appear at a lower point in the interior.

Tilt of Vehicle

Some leaks may occur with the vehicle in a tilted position causing designed drains to back up especially if large amounts of water are involved.

High Water Pressure

During washing or windstorms high water pressure may force water through seals and crevices or cause drains to back up and overflow.

Drains

Certain vehicle areas have designed drains to direct water to the outside. For example, drains are found on the bottom of the doors or around the door openings of the body to allow water that entered at the window lip seals, which due to their function cannot provide a full seal, to escape to the outside. Water entering through the gap of the doors is drained to the outside. Due to their function, all drains must be free of obstruction and seals (watertight) from the rest of the body.

Sealing

The joints of the body panels, windows, ducts, and cable passages are sealed in areas where water entering at these points would drain to the inside.

Continued...

ST-33-12/81
Water Leaks - Body
Page 2

Owner observations and thorough knowledge of the vehicle sealing and draining areas will greatly assist in locating a water leak.

The attachment to this bulletin identifies sealed joints of the DMC vehicle body.

When sealing the indicated joints use Dow Silastic 732 R.T.V or equivalent.

William A. Charles
Director, Service/Parts

WAC:ak

Attachment

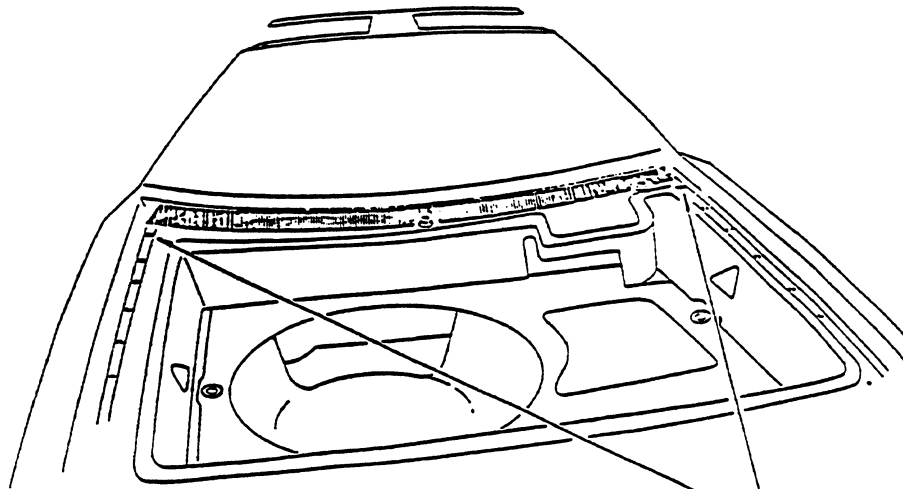

REMOVE THE TWO REAR-
MOST ATTACHMENT BOLTS OF
FRONT FENDERS & PLUS RIVNUT
WITH SILASTIC & REFIT ATTACHMENT BOLTS.

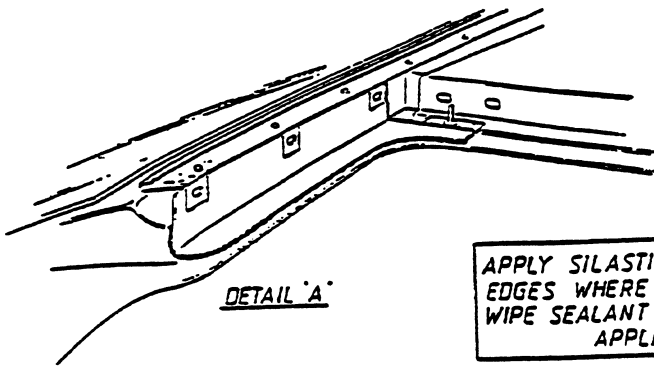

DETAIL 'A'

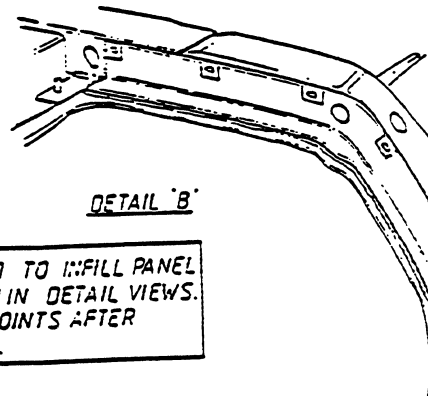

DETAIL 'B'

APPLY SILASTIC BEAD TO INFILL PANEL
EDGES WHERE SHOWN IN DETAIL VIEWS.
WIPE SEALANT INTO JOINTS AFTER
APPLICATION.

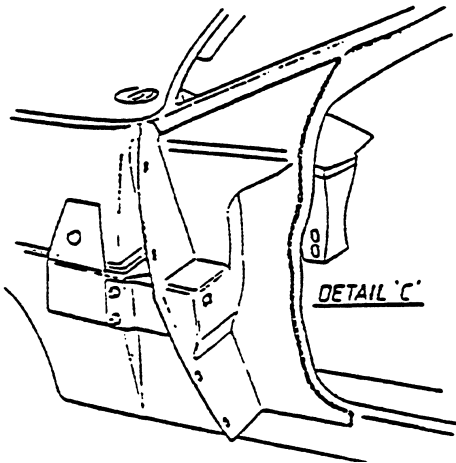

DETAIL 'C'

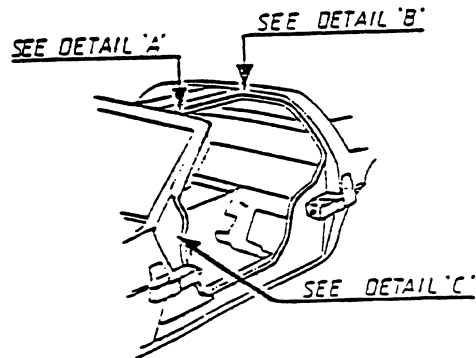

SEE DETAIL 'A'

SEE DETAIL 'B'

SEE DETAIL 'C'

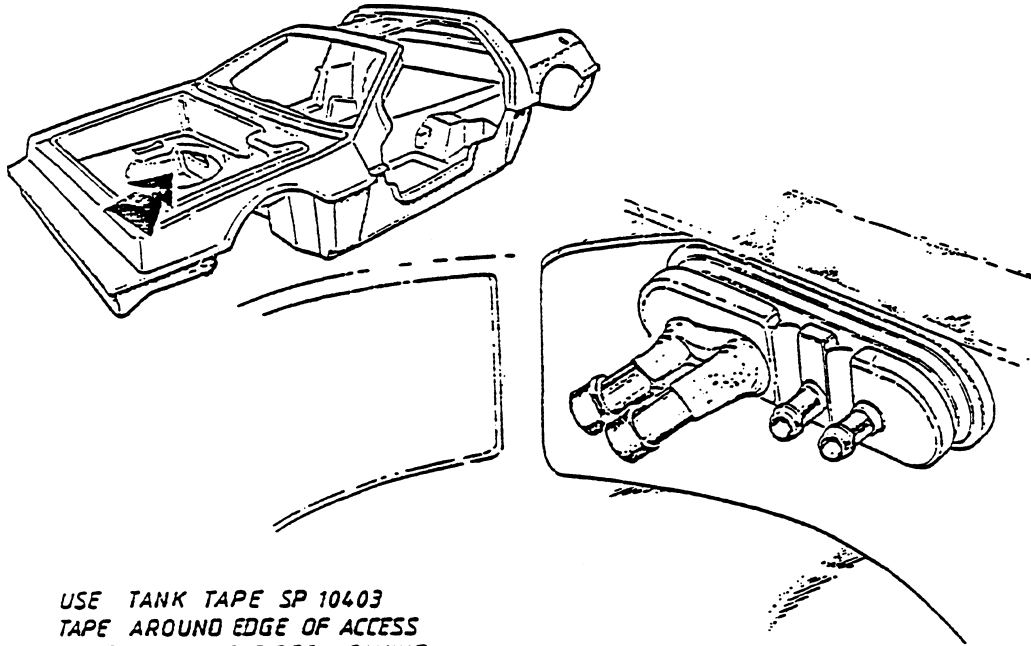

USE TANK TAPE SP 10403
TAPE AROUND EDGE OF ACCESS
HOLE FOR A.C. PIPES LEAVING
SUFFICIENT SLACK BETWEEN
PIPES TO ALLOW TAPE TO BE
PUSHED THROUGH AND STUCK
TO ITSELF. PRESS TAPE FIRMLY
AROUND PIPES.

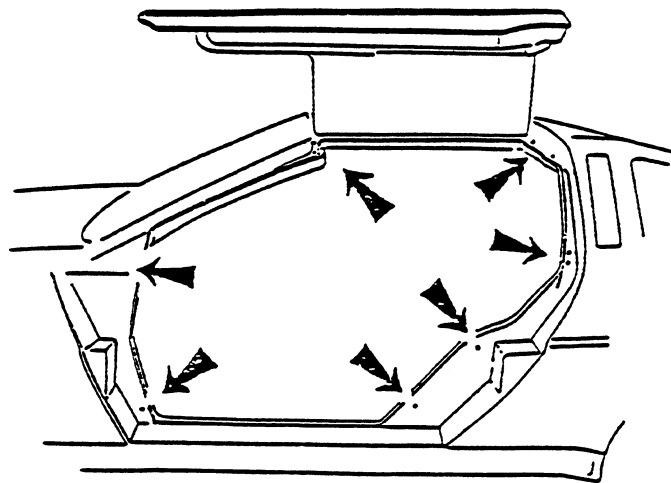

REMOVE SELF TAPPERS FROM INFILL PANELS
AND SEAL HOLES WITH PLASTIC REPT SCREWS

SEAL TOP TO BOTTOM
SHELL JOINT LINE INSIDE
HOOD AREA
WIPE SILASTIC INTO
JOINT LINE

REMOVE SCREWS AND
FILL RIVNUTS WITH SILASTIC
AND REFIT SCREWS.
APPLY BEAD OF SILASTIC
AROUND PANEL EDGES AND
WIPE INTO JOINT.

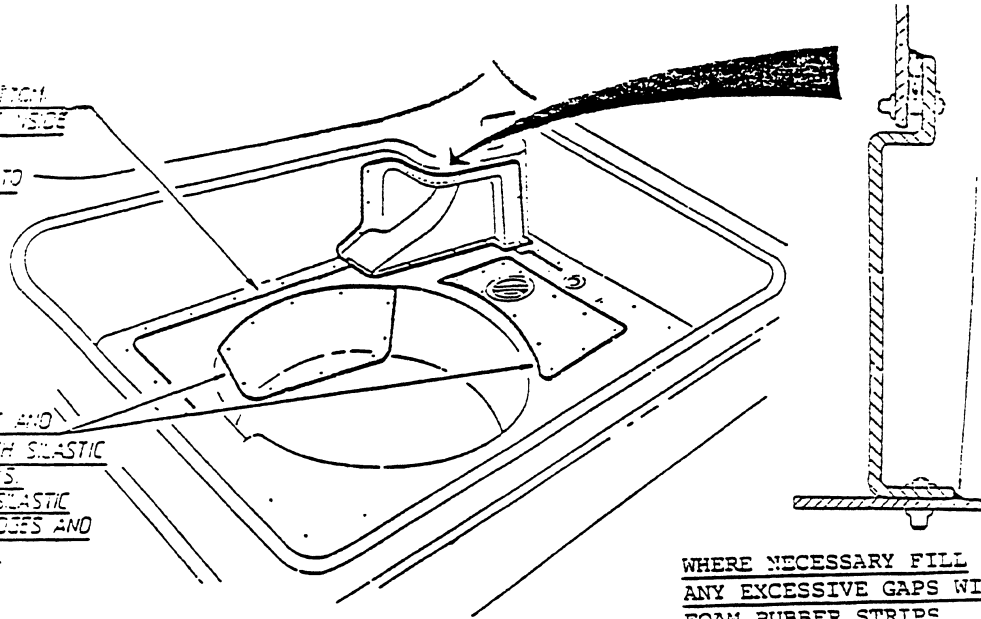

WHERE NECESSARY FILL
ANY EXCESSIVE GAPS WITH
FOAM RUBBER STRIPS
BEFORE SEALING WITH A
BEAD OF SILASTIC

SEAL MATING FACE OF PEDAL
BOX WITH BEAD OF SEALANT
IMMEDIATELY BEFORE MOUNTING
TO CAR, USING DOW SILASTIC
RTV SEALANT.

CLUTCH CYLINDER MOUNTING AREA MUST
BE KEPT FREE OF SEALANT.

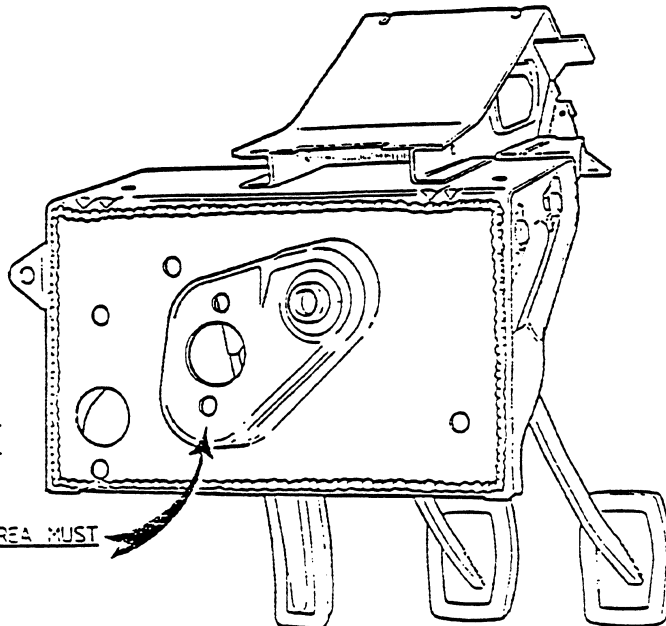

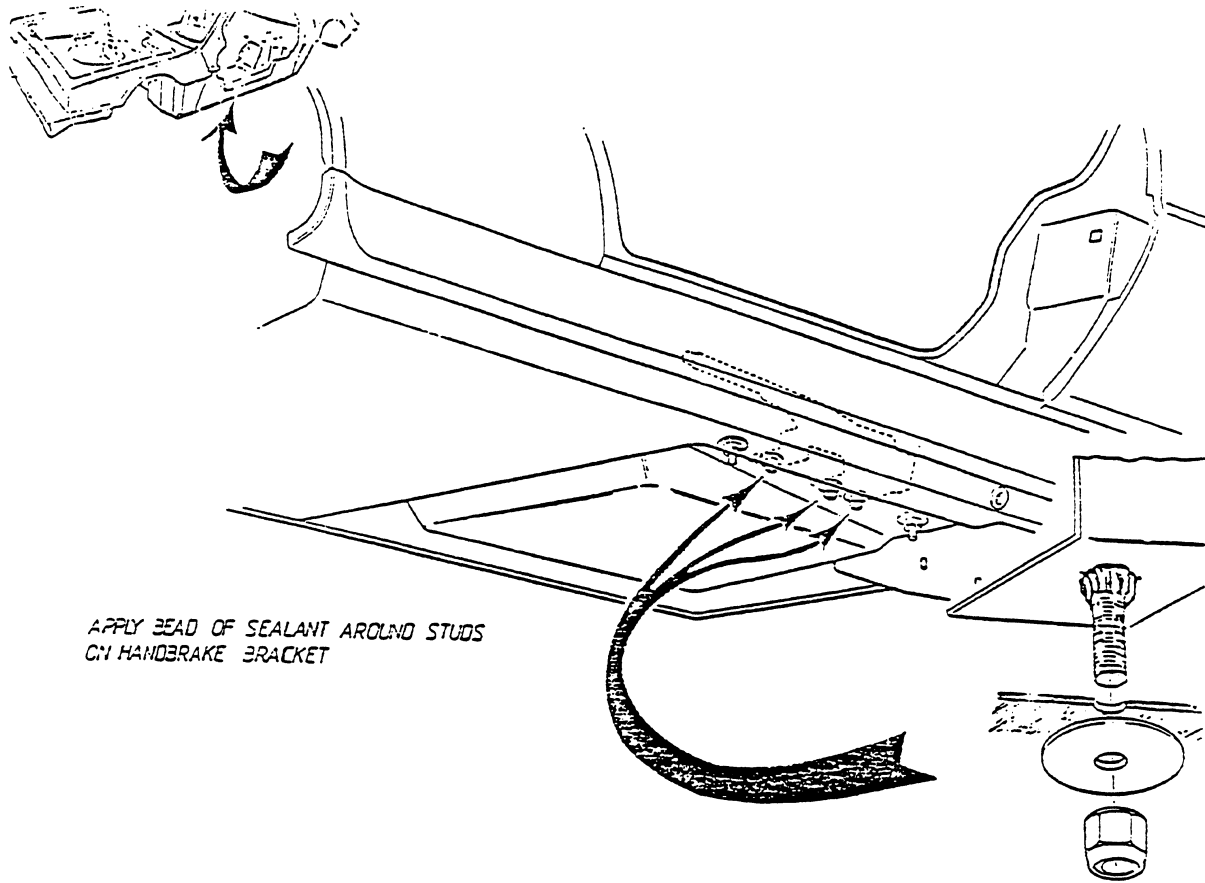

APPLY BEAD OF SEALANT AROUND STUDS
ON HANDBRAKE BRACKET

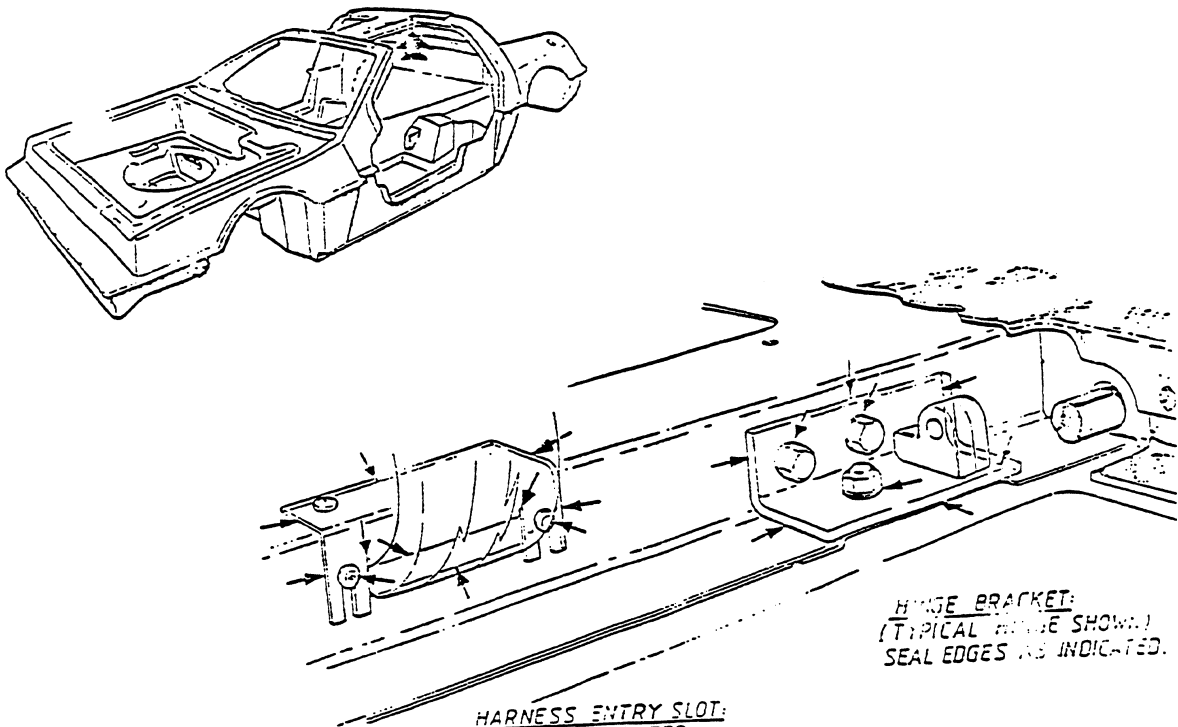

HARNES ENTRY SLOT:
SEAL AS INDICATED.
WIPE BEADS INTO JOINTS
ENSURE FOAM STRIPS
HAVE BEEN FITTED.

HINGE BRACKET:
(TYPICAL HINGE SHOWN)
SEAL EDGES AS INDICATED.

NOTE:
FRUCTION BAR, HINGE AND
DOOR EDGES OMITTED
FOR CLARITY.

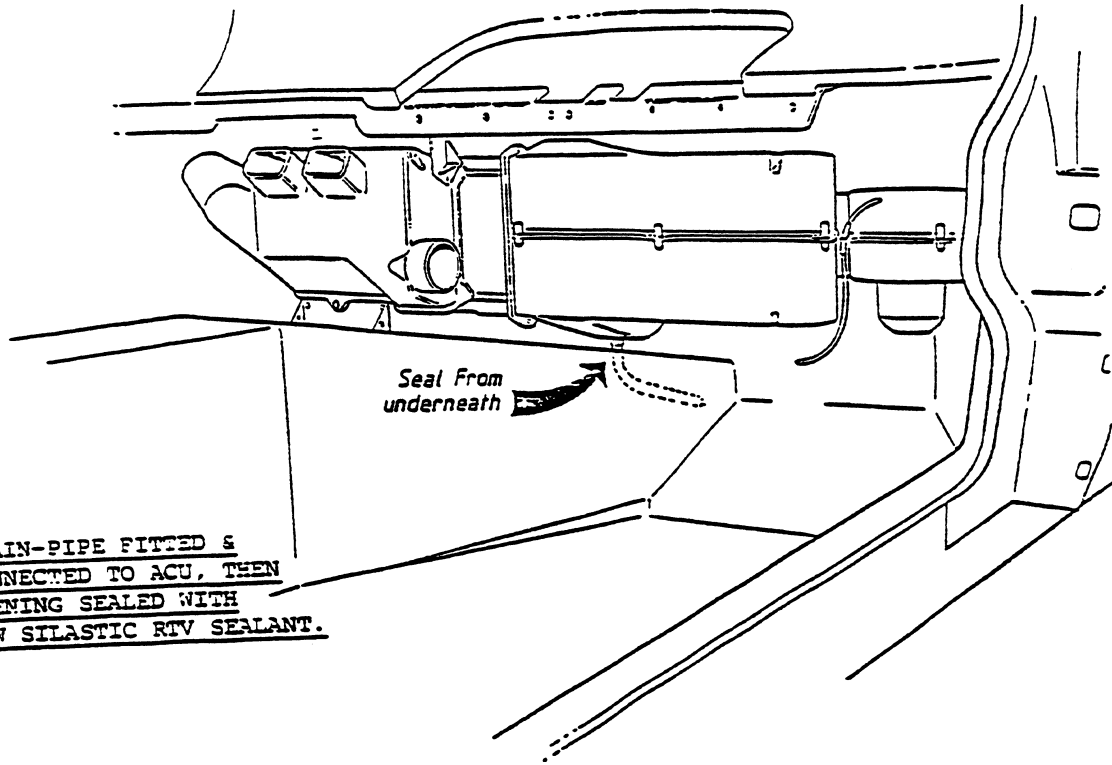

DRAIN-PIPE FITTED &
CONNECTED TO ACU, THEN
OPENING SEALED WITH
DOW SILASTIC RTV SEALANT.

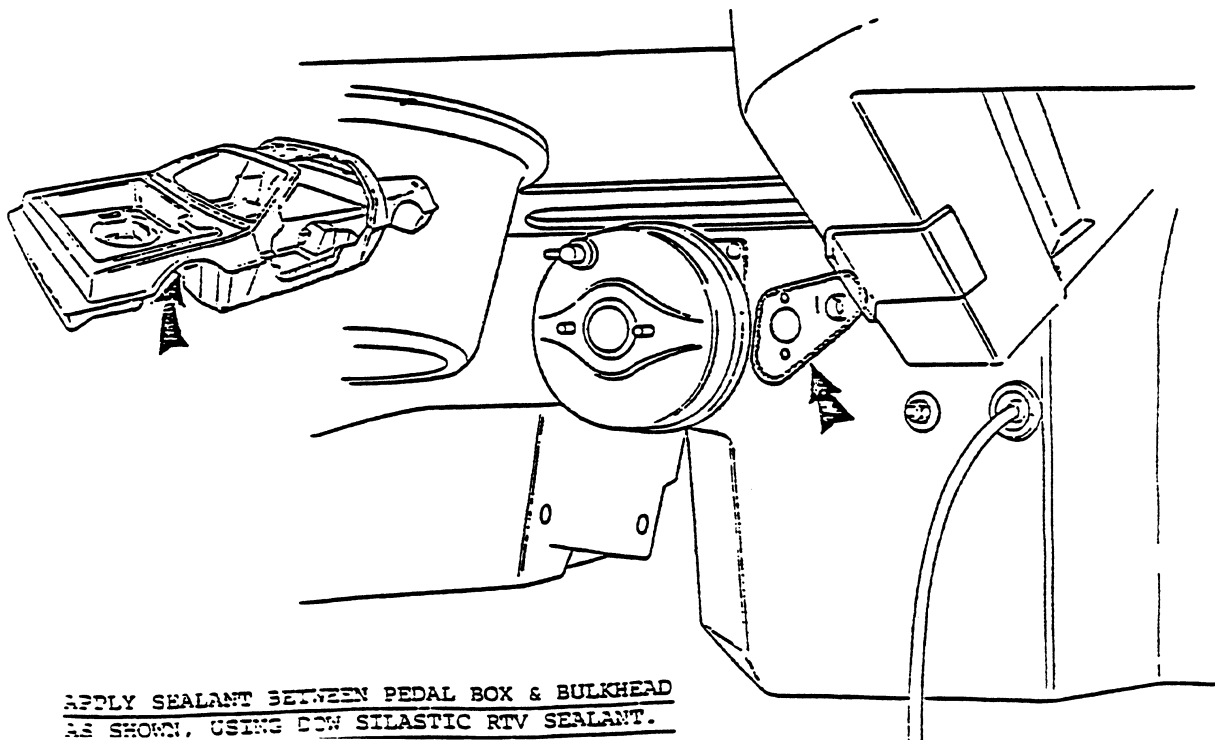

APPLY SEALANT BETWEEN PEDAL BOX & BULKHEAD
AS SHOWN, USING DOW SILASTIC RTV SEALANT.

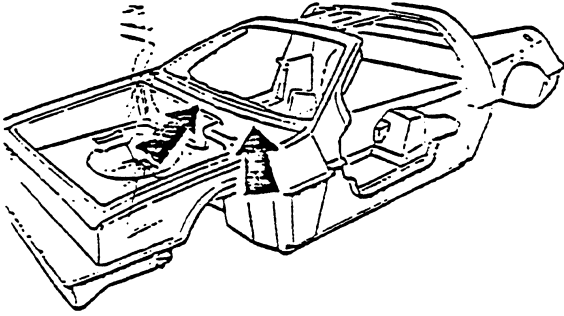

APPLY SILASTIC BEAD TO BODY
AROUND WIPER STEM - FIT RUBBER
WASHER - APPLY SECOND BEAD OF
SILASTIC TO WASHER - ASSEMBLE
AS NORMAL

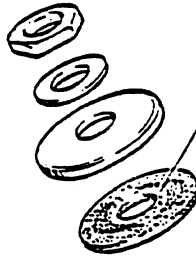

2nd SEALANT BEAD APPLIED AROUND HERE
AFTER FITTING RUBBER WASHER IN PLACE.



1st SEALANT BEAD APPLIED
AROUND HERE BEFORE FITTING
RUBBER WASHER IN PLACE.

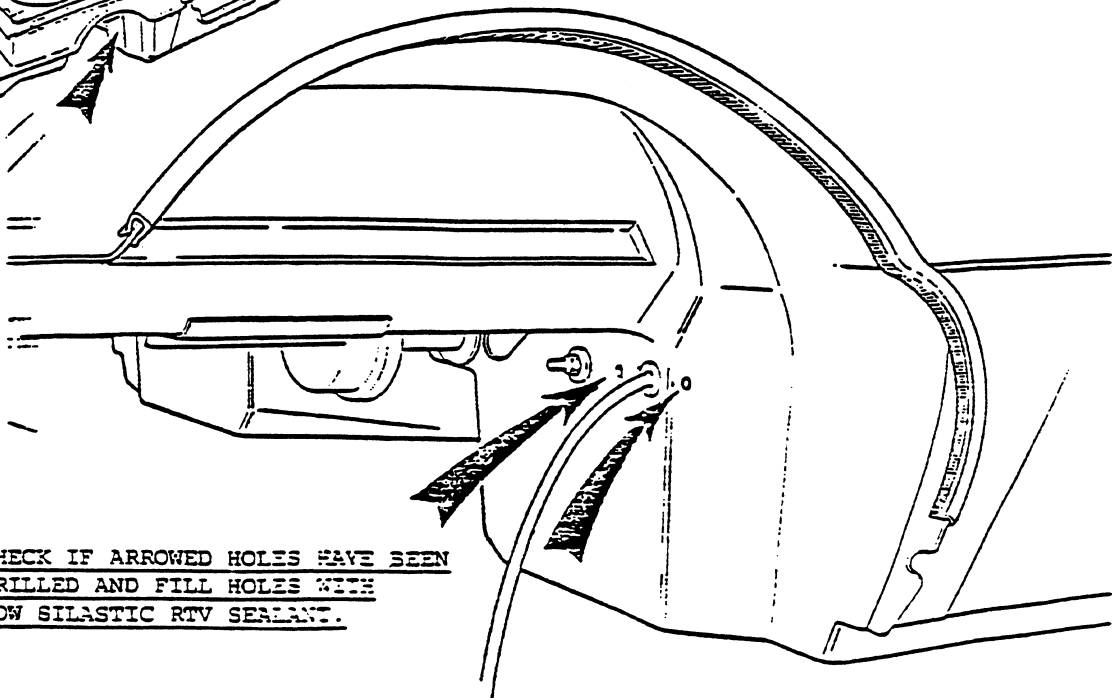
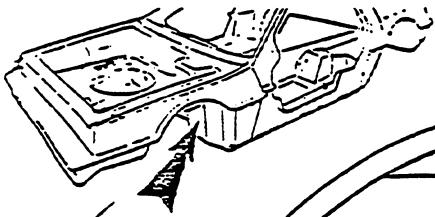

CHECK IF ARROWED HOLES HAVE BEEN
DRILLED AND FILL HOLES WITH
DOW SILASTIC RTV SEALANT.



FOUR OFF BIG HEAD BOLTS
IN ROOF AREA SEALED AS
SHOWN WITH DOW SILASTIC RTV
SEALANT.

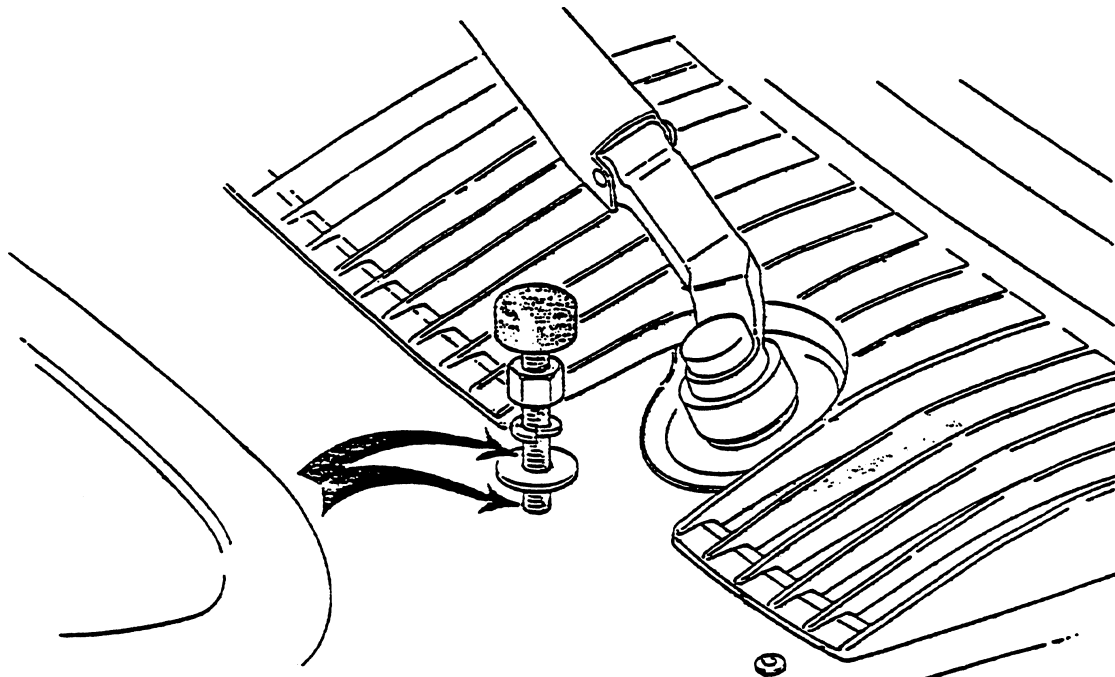
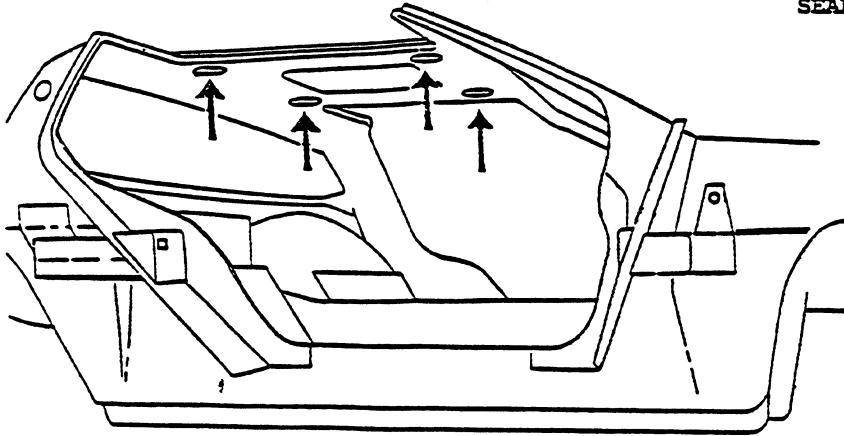

HOOD BUMP STOPS :
UNSCREW TOP NUT, LIFT WASHER & APPLY BLACK SILASTIC
SEALANT ABOVE AND BELOW THE WASHER. RETIGHTEN THE
TOP NUT. WIPE OFF EXCESS SEALANT.
THE ADJUSTMENT OF THE BUMP STOP MUST NOT BE UPSET.



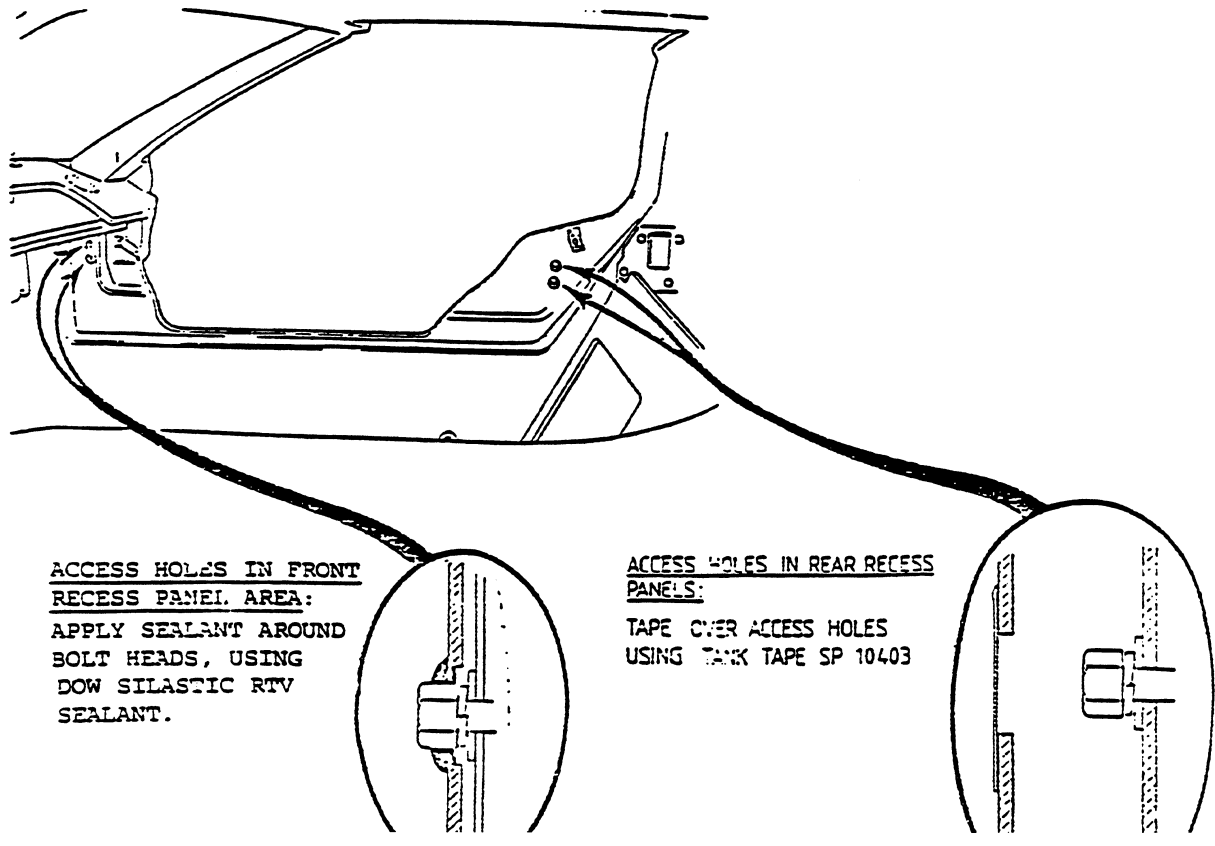
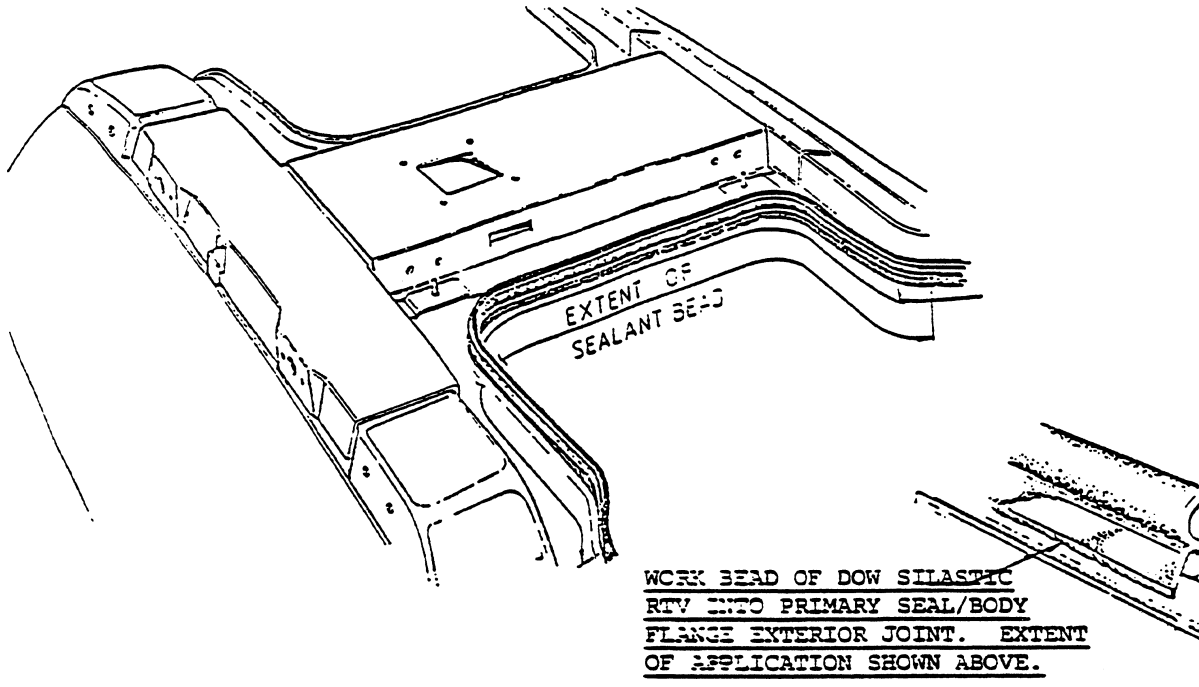

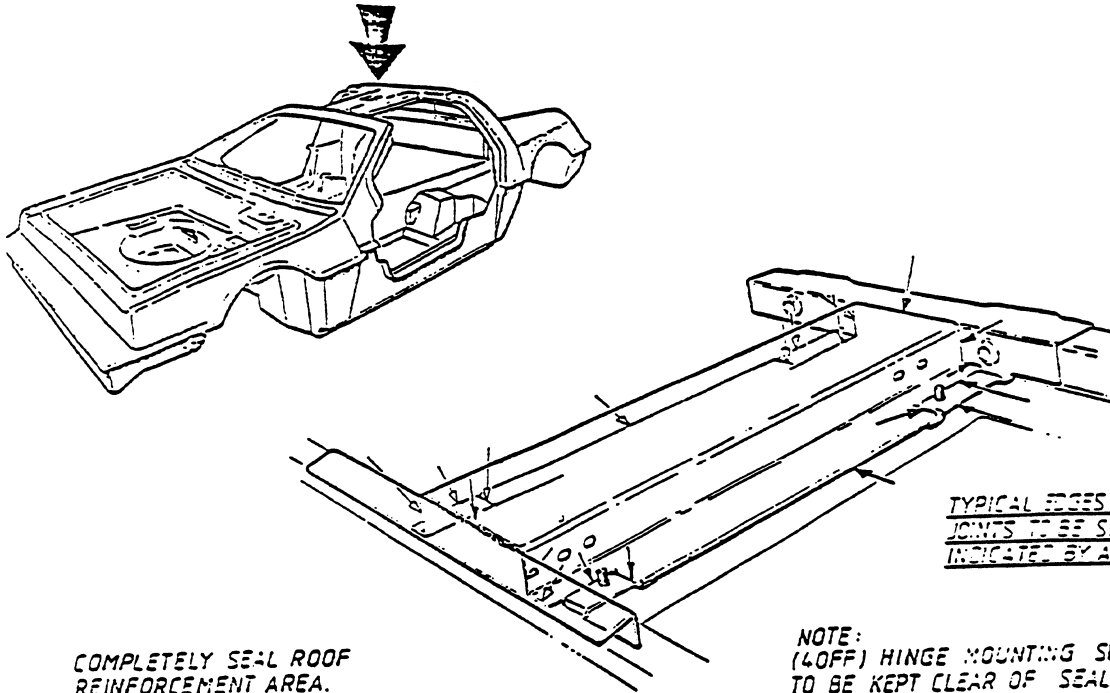

COMPLETELY SEAL ROOF
REINFORCEMENT AREA.
SEALANT TO BE USED IS
RTV 732 SILASTIC.
SEALANT BEAD TO BE 'WIPED'
INTO JOINT AFTER APPLICATION.

NOTE:
(4OFF) HINGE MOUNTING SURFACES
TO BE KEPT CLEAR OF SEALANT.

TYPICAL EDGES AND
JOINTS TO BE SEALED
INDICATED BY ARROWS

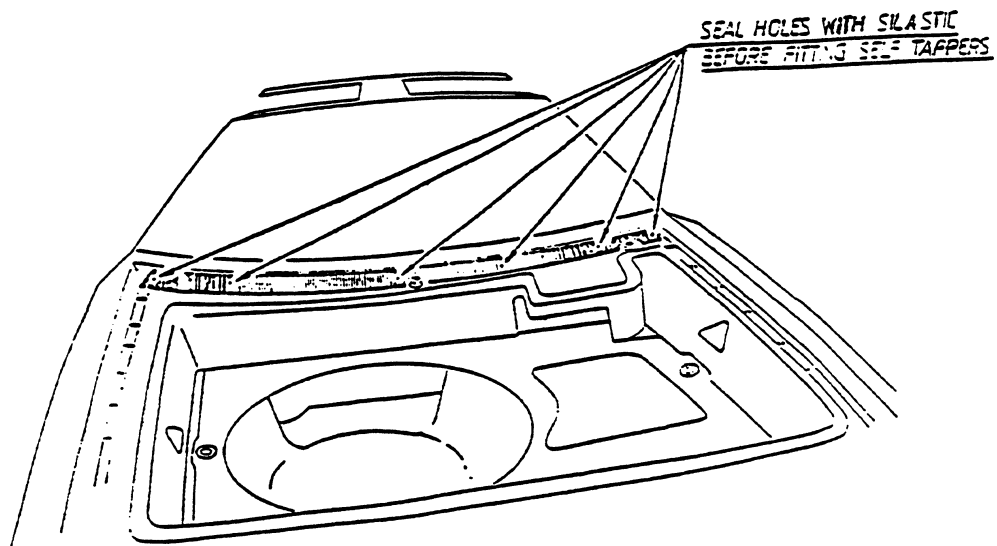

SEAL HOLES WITH SILASTIC
BEFORE FITTING SELF TAPPERS

