



DE LOREAN MOTOR COMPANY

SERVICE BULLETIN

NUMBER ST-12-9/81

CATEGORY: TECHNICAL

ATTENTION: ALL DMC DEALERS/SERVICE MANAGERS

SUBJECT: UPDATE SERVICE BULLETIN ST-07-7/81

Attached, please find a new attachment for the above bulletin.

Please replace previous pages with the new ones.

Sincerely,

Lutz Feuerabendt
Technical Service Manager

LF:dg

attachment (s)

ISSUED 9/2/81

FENDER MOUNTED ANTENNA

INSTALLATION

1. Raise luggage compartment cover.
2. Using a hole saw, locate and drill a 1" diameter hole in the top of the right front fender approximately 4" from the rear of the fender. (See figure 1).

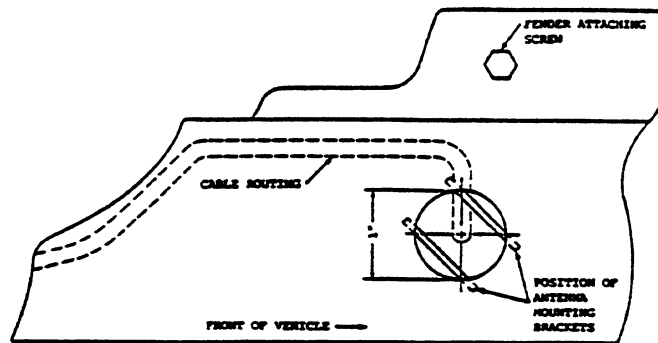

FIGURE 1

3. After cutting through the fender, continue to cut into the composite underbody approximately 1" deep as measured from the fender. (See inset - figure 2).

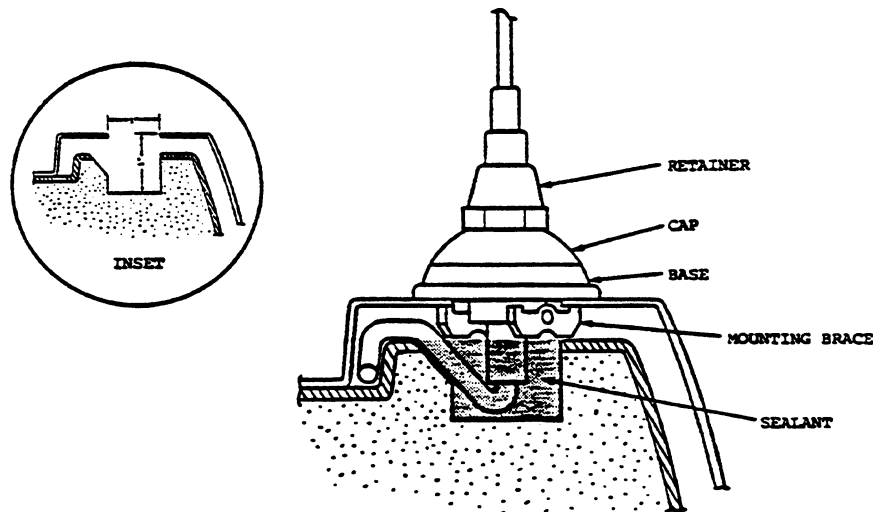

FIGURE 2

4. Using the hole saw, shave off the composite underbody away from the inboard 1/3 ridge of the hole cut in step 3 to obtain necessary clearance for antenna installation. (See figure 2).

To properly seal this drilled hole, coat the inside of the drilled area with Dow-Corning Sealastic Sealant/Adhesive (Dow Part #732). Also see step 8.

5. Working inside the vehicle and using a hole saw, drill a 1" hole in the triangular shaped recess area located above both the carpet and body seam of the right kick panel. (See figure 3).

Notice: Care should be exercised when drilling to avoid damaging the front fender.

Caution: This hold should be located far enough forward to avoid performing the exposed door jam area.

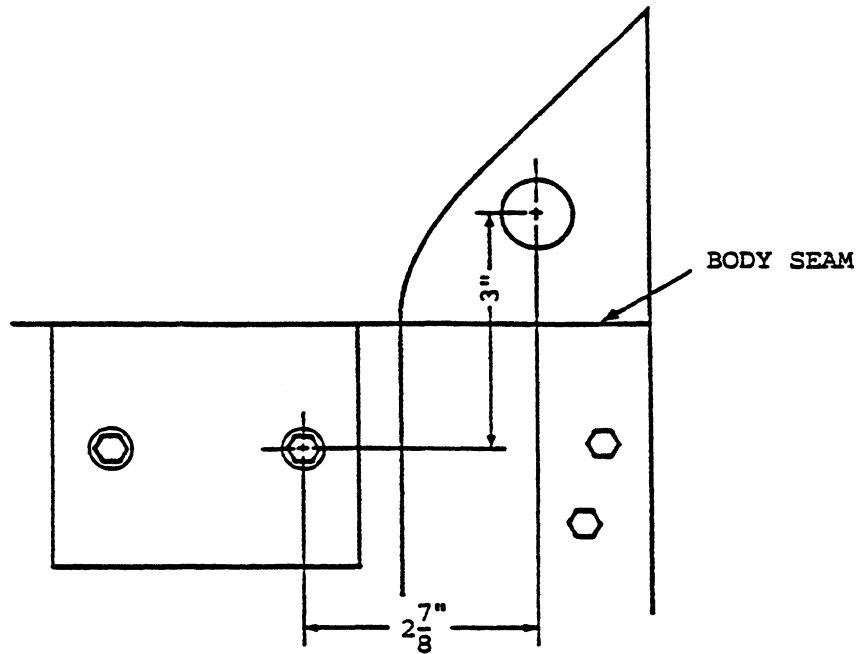

FIGURE 3

6. Route the antenna's cable into the fender (as illustrated in figure 1) and towards the direction of the hole drilled in the right kick panel.

Notice: Care should be exercised when routing the cable not to "trap" the cable under the antenna's mounting braces.

7. Working inside the vehicle, guide the cable through the hole drilled in the kick panel area with an appropriate tool. Draw enough cable through the hole to eliminate excessive cable slack inside the fender area.
8. Before positioning and securing the antenna assembly on the fender, completely fill the drilled antenna hole in the composite underbody with Dow-Corning Sealastic Sealant/Adhesive (Dow Part #732). (Obtain locally).

9. Position the antenna's mounting braces as illustrated in figure 1 and secure antenna as illustrated in figure 2.
10. Working inside vehicle, route and secure cable to radio assembly.
11. Unplug windshield antenna and plug fender-mounted antenna cable.
12. Seal the hole in the kick panel area (with cable routed) with a standard 1" grommet.
13. Test radio for AM and FM reception.
14. Clean up vehicle as required.

REIMBURSEMENT

Complete and submit Service Transaction General Form with entries on:

Line A 3 through 16 (self explanatory)

Line B1 Enter 30

Line B2 See general instructions - Bulletin SW-01

Line B12 Enter SA-0002

Labor .5 time units = (30 min.)

Parts W-200001 (Materials) = \$1.70 (sealant/grommet)

No entry is made for the antenna which is supplied free of charge.