

# G - TESTS W/CODES - TURBO

1995 Volvo 850

1995 ENGINE PERFORMANCE  
Volvo - Self-Diagnostics

850 Turbo

## INTRODUCTION

If no faults were found while performing BASIC DIAGNOSTIC PROCEDURES, proceed with SELF-DIAGNOSTIC SYSTEM. If no fault codes or only pass codes are present, proceed to H - TESTS W/O CODES article for diagnosis by symptom (i.e., ROUGH IDLE, NO START, etc.).

NOTE: All voltage tests should be performed using a Digital Volt-Ohmmeter (DVOM) with a minimum 10-megohm input impedance, unless specifically stated otherwise in testing procedures.

## SELF-DIAGNOSTIC SYSTEM

850 turbo uses a Motronic 4.3 control system, which has a single Electronic Control Module (ECM) to control fuel injection and ignition systems. In addition, Motronic 4.3 control system incorporates an on-board diagnostic function. Signals from various sensors are monitored continuously. If certain signals are lost or become faulty, ECM will adopt fixed substitute values (limp-home mode) to enable vehicle to be driven for certain failures. Substitute values can be adopted for Engine Coolant Temperature (ECT) sensor signal, Throttle Position (TP) sensor signal, Mass Airflow (MAF) sensor signal, and oxygen sensor (HO2S) signal. See Fig. 1.

NOTE: To avoid confusion thinking there is an intermittent malfunction with Malfunction Indicator Light (MIL), carefully read following text.

ECM stores Diagnostic Trouble Codes (DTCs) differently in accordance with a predetermined pattern. An emission related fault must be present for a predetermined number of intervals before ECM permanently stores a DTC and illuminates Malfunction Indicator Light (MIL). If fault is cleared before a specified interval has passed, DTC is erased from memory. There are 3 main types of intervals:

- \* Trip - All diagnostic functions have been performed.
- \* Running Cycle - Fuel trim (closed loop) has been initiated.
- \* Time - Time in seconds.

If a fault disappears for any reason after DTC has been recorded permanently by ECM, DTC information will be retained by ECM. Each time the fault occurs, first counter will advance one. Each trip completed without a reoccurrence, a second counter will count down from 3 to zero. When second counter has reached zero, MIL will extinguish (if illuminated) and a third counter will start counting down. The third counter counts number of warm-up cycles (starting at 40). A warm-up cycle is when engine temperature is less than 104°F (40°C) at engine start and exceeds 183°F (84°C). When third counter reaches zero, DTC is erased from ECM memory. If a fault reoccurs, the second and third counter revert to their original settings and the first counter advances one.

Faults are recorded in ECM memory in the form of Diagnostic Trouble Codes (DTCs). Codes can be displayed using one of 4 methods:

- \* Using LED on Volvo diagnostic unit in engine compartment to display codes. See Fig. 1.
- \* Using Volvo Scan Tool (998-8686) connected to Volvo Data Link Connector (DLC) in engine compartment.
- \* Using a generic scan tester connected to On-Board Diagnostics II (OBD II) Data Link Connector (DLC). DLC is located in center console in front of gear shift lever. See Fig. 3.

On-board diagnostic unit for retrieving codes is located in right front of engine compartment. Diagnostic unit is equipped with an LED indicator, activation button and function select cable.

Diagnostic unit output socket No. 2 is used to retrieve codes. Once selector cable has been inserted in correct slot, depressing button once, twice or 3 times selects from one of 3 control (fault tracing) functions. Faults stored in ECM memory are read by observing LED flashes.

All fault codes contain 3 digits (example: 2-1-3). Since codes have 3 digits, each code requires 3 series of flashes. A 3-second interval separates series of flashes. See Fig. 2.

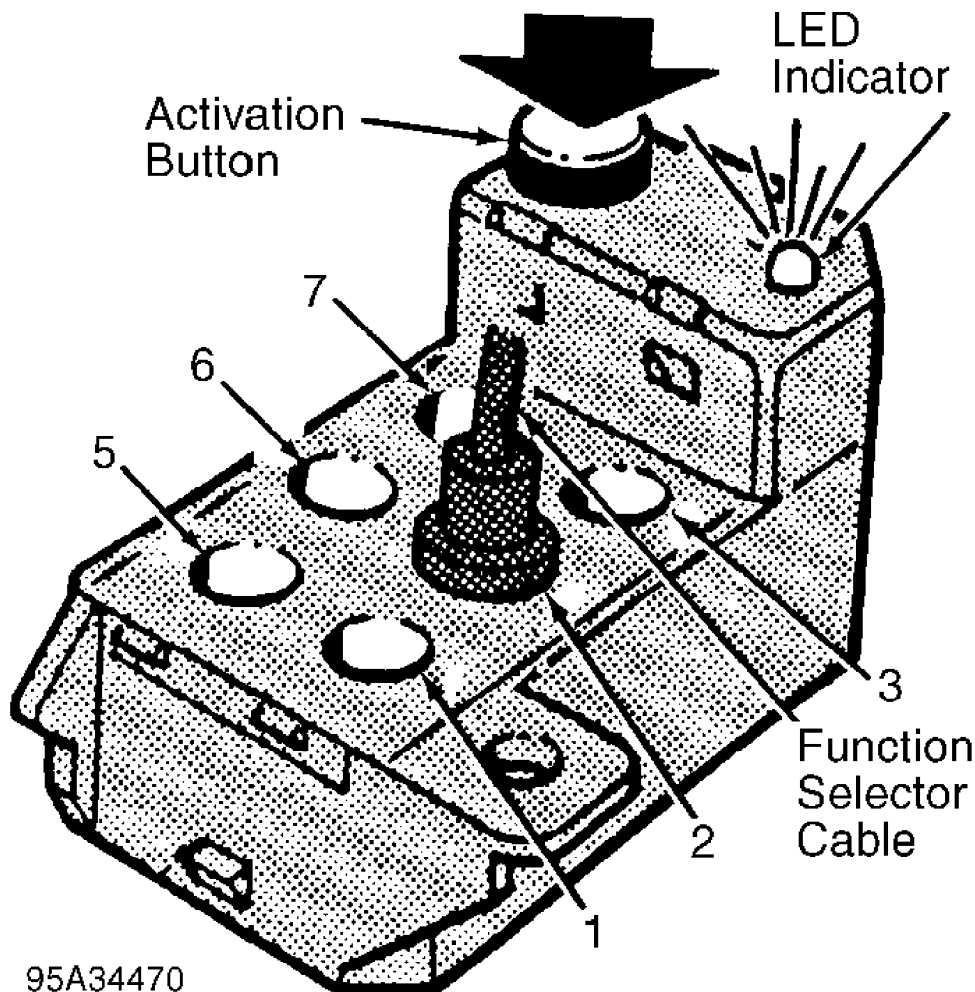

95A34470

Fig. 1: Identifying Diagnostic Unit  
 Courtesy of Volvo Cars of North America.

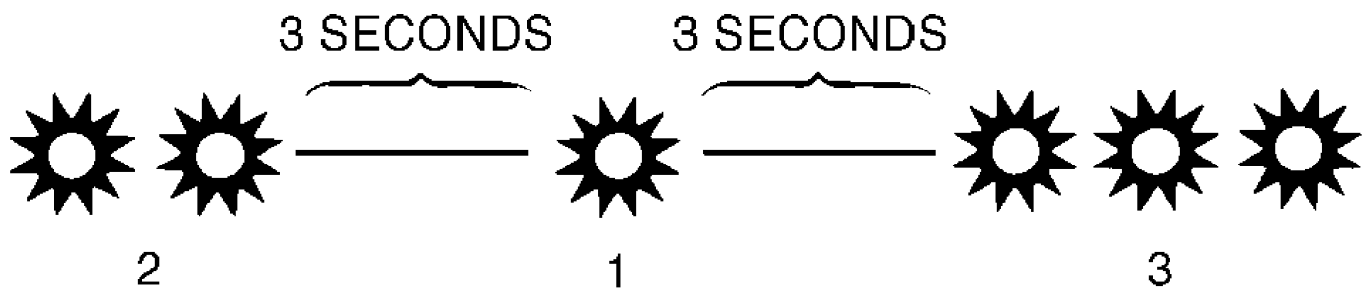

91E16646

Fig. 2: Counting Red LED Code Flashes For Code 2-1-3  
 Courtesy of Volvo Cars of North America.

### RETRIEVING CODES

**CAUTION:** Never disconnect or connect ECM connector with ignition switch in ON position.

Follow tool manufacturer's instructions if retrieving codes with Volvo Diagnostic Key Scan Tool, Volvo Scan Tool (998-8686) or generic scan tool. Volvo Diagnostic Key Scan Tool and Volvo Scan Tool must be connected to Volvo DLC located in engine compartment. Generic scan tool must be connected to DLC located in console in front of gear shift lever. See Fig. 3.

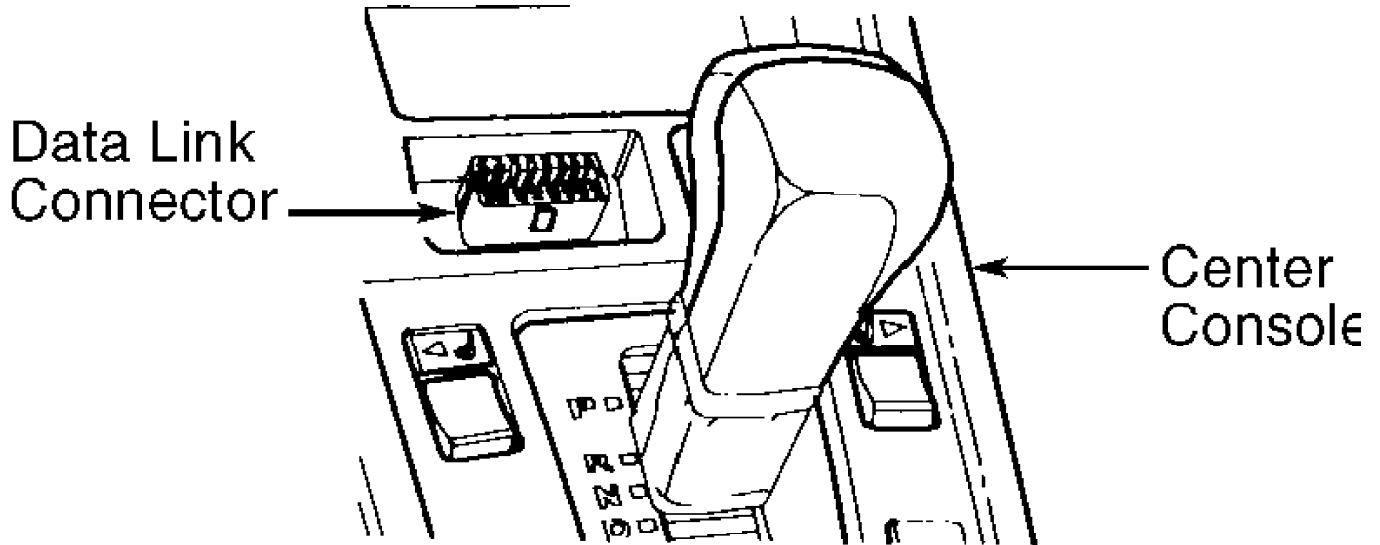

94F46057

Fig. 3: Locating Data Link Connector (DLC)  
 Courtesy of Volvo Cars of North America.

#### On-Board Diagnostics (OBD) II

OBD II is a legally required diagnostic system. OBD II DLC enables a generic scan tool to be connected to management system to read codes and parameters which alter exhaust emission levels. Information provided is not as comprehensive as that provided by Volvo self-diagnostics or Volvo Scan Tool (998-8686).

#### Volvo Self-Diagnostic System

System is capable of self-diagnostic functions through the use of Volvo diagnostic unit in engine compartment. System has 3 test modes. Test mode No. 1 is used to display and erase codes. Test mode

No. 2 is used to verify operation of system components. Test mode No. 3 operates components in a certain order. Access to diagnostic system is provided by socket No. 2 on diagnostic unit with ignition on.

CAUTION: After displaying DTCs, ignition must be switched off BEFORE engine is started.

#### Test Mode No. 1 (Displaying Codes)

1) To retrieve codes, open Volvo diagnostic unit cover (located in right corner of engine compartment) and connect test lead to socket No. 2. Turn ignition on. Enter test mode No. 1 by pressing test button once for 1-3 seconds.

2) Observe LED, and count number of flashes in 3 digit series comprising a fault code. Because series are displayed at 3-second intervals, codes can be easily distinguished.

3) If a fault code is retrieved, refer to the TROUBLE CODE DEFINITION table under TROUBLE CODE IDENTIFICATION. Depress push button again, and check for additional codes. Depress push button a third time if necessary. If first code repeats, no other codes are present.

#### Test Mode No. 1 (Erasing Codes)

1) Codes can be erased only after all DTCs have been displayed and first DTC has been repeated at least once. To erase DTC, turn ignition on. Press test button on Volvo diagnostic unit and hold for more than 5 seconds. Wait for LED response.

2) Press button again and hold for more than 5 seconds. Turn ignition off and on. Start engine. All DTCs will be erased and all adaptive values reset.

#### Test Mode No. 2 (Verifying Operation Of System Components)

This test mode is activated by briefly pressing test button on Volvo diagnostic unit 2 times, causing LED to rapidly flash. ECM will flash a code indicating receipt of a signal from following components with ignition on:

- \* 3-3-2 - TP sensor (throttle moved from or to idle).
- \* 3-3-3 - TP sensor (throttle moved from or to WOT).
- \* 1-2-4 - Transmission Control Module (TCM), when gear selector is moved from or to a drive position.

Control unit will flash a code indicating receipt of a signal from following components with engine running:

- \* 1-1-4 - A/C control, when A/C button is depressed or released.
- \* 1-3-4 - A/C compressor running.
- \* 1-4-1 - RPM sensor.
- \* 3-4-2 - Camshaft Position (CMP) sensor.
- \* 3-4-3 - Vehicle Speed Sensor (VSS).

NOTE: For test mode No. 3 to operate correctly, 3 injectors must be disconnected. Reconnect injectors after completion of test.

#### Test Mode No. 3 (Operating Components In A Certain Order)

This function is activated by briefly pressing test button on Volvo diagnostic unit 3 times. Electronic Control Module (ECM) will respond by activating listed components in order. This sequence is repeated twice. Test mode No. 3 cannot be activated while engine is running. The following components are operated:

- \* EGR vacuum controller.

- \* Turbocharger (TC) control valve.
- \* EVAP valve.
- \* Engine cooling fan, low speed.
- \* Engine cooling fan, high speed.
- \* Injectors.
- \* IAC valve.
- \* A/C relay.
- \* RPM (tachometer indicates 1250-1500 RPM).

## TROUBLE CODE IDENTIFICATION

### TROUBLE CODE DEFINITION

Code	OBD II Code	Fault
1-1-1		No Faults Detected By OBD System
1-1-2	P0605, P1326, P1329, P1401, P1403, P1404	Fault In ECM
1-1-5	P0201	Injector No. 1
1-2-1	P0102, P0103	MAF Sensor Signal
1-2-3	P0116, P0117, P0118	ECT Signal
1-2-5	P0202	Injector No. 2
1-3-1		RPM Sensor Signal Missing
1-3-2		Battery Voltage
1-3-5	P0203	Injector No. 3
1-4-3	P0326	Front Knock Sensor Signal
1-4-5	P0204	Injector No. 4
1-5-3	P0136, P0137, P0138	Rear HO2S Signal
1-5-4	P0402	EGR System Leakage
1-5-5	P0205	Injector No. 5
2-1-2	P0130, P0131, P0132	Front HO2S Signal
2-1-4	P0336	RPM Sensor Signal Sporadic
2-2-3	P1505, P1506	IAC Valve Opening Signal
2-2-5		A/C Pressure Sensor Signal
2-3-1	P0171, P0172	Long Term Fuel Trim Part Load
2-3-2	P0171, P0172	Long Term Fuel Trim Idling
2-3-3		Long Term Idle Air Trim
2-4-1	P0400	EGR System Flow Malfunction
2-4-5	P1507	IAC Valve Closing Signal
3-1-1		VSS Signal

3-1-4		CMP Sensor Signal
3-1-5		EVAP System
3-2-5		Memory Failure
3-3-5	P1617, P1618	Request For MIL From TCM
4-1-1	P0122, P0123	TP Sensor Signal
4-1-3	P1416, P1417, P1418	EGR Temperature Sensor Signal
4-1-4		Boost Pressure Regulation
4-1-6		Boost Pressure Reduction From TCM
4-3-2		Temperature Warning Level No. 1
4-2-5	P0140	Temperature Warning Level No. 1
4-3-3	P0331	Rear Knock Sensor Signal
4-3-5	P0133	Front HO2S Slow Response
4-3-6	P0133	Rear HO2S Compensation
4-4-3	P0422	TWC Efficiency
4-4-4	P1307, P1308	Acceleration Sensor Signal
4-5-1	P0301	Misfire Cylinder No. 1
4-5-2	P0302	Misfire Cylinder No. 2
4-5-3	P0303	Misfire Cylinder No. 3
4-5-4	P0304	Misfire Cylinder No. 4
4-5-5	P0305	Misfire Cylinder No. 5
5-1-3	P1405	Temperature Warning Level No. 2
5-1-4		Engine Cooling Fan Low Speed Signal
5-2-1	P0135	Front HO2S Preheating
5-2-2	P0141	Rear HO2S Prr No. 2
4-5-3	P0303	Misfire Cylinder No. 3
4-5-4	P0304	Misfire Cylinder No. 4
4-5-5	P0305	Misfire Cylinder No. 5
5-1-3	P1405	Temperature Warning Level No. 2
5-1-4		Engine Cooling Fan Low Speed Signal
5-2-1	P0135	Front HO2S Preheating
5-2-2	P0141	Rear HO2S Preheating

5-3-1	P1101	Power Stage Group A
5-3-2	P1102	Power Stage Group B
5-3-3		Power Stage Group C
5-3-4		Power Stage Group D
5-3-5		TC Control Valve Signal
5-4-1	P0444, P0445	EVAP Valve Signal
5-4-2	P0300	Misfire On More Than One Cylinder
5-4-3	P1310	Misfire On At Least One Cylinder
5-4-4	P0300	Misfire On More Than One Cylinder/TWC Damage
5-4-5	P1310	Misfire On At Least One Cylinder/TWC Damage
5-5-1	P0301	Misfire Cylinder No. 1/TWC Damage
5-5-2	P0302	Misfire Cylinder No. 2/TWC Damage
5-5-3	P0303	Misfire Cylinder No. 3/TWC Damage
5-5-4	P0304	Misfire Cylinder No. 4/TWC Damage
5-5-5	P0305	Misfire Cylinder No. 5/TWC Damage

## CLEARING CODES

1) Codes can be erased only after all DTCs have been displayed and first DTC has been repeated at least once. See RETRIEVING CODES. To erase DTC, turn ignition on. Press test button on Volvo diagnostic unit and hold for more than 5 seconds. Wait for LED response.

2) Press button again and hold for more than 5 seconds. Turn ignition off and on. Start engine. All DTCs will be erased and all adaptive values reset.

## ECM LOCATION

Motronic 4.3 Electronic Control Module (ECM) is located in right front of engine compartment, in front of strut tower.

## SUMMARY

If no hard fault codes (or only pass codes) are present, driveability symptoms exist or intermittent codes exist, proceed to the H - TESTS W/O CODES article for diagnosis by symptom (i.e., ROUGH IDLE, NO START, etc.) or intermittent diagnostic procedures.

## DIAGNOSTIC TROUBLE CODE TESTING

### MOTRONIC 4.3 CONTROL SYSTEM

NOTE: For connector terminal identification, see Figs. 4-10 and the

L - WIRING DIAGRAMS article.

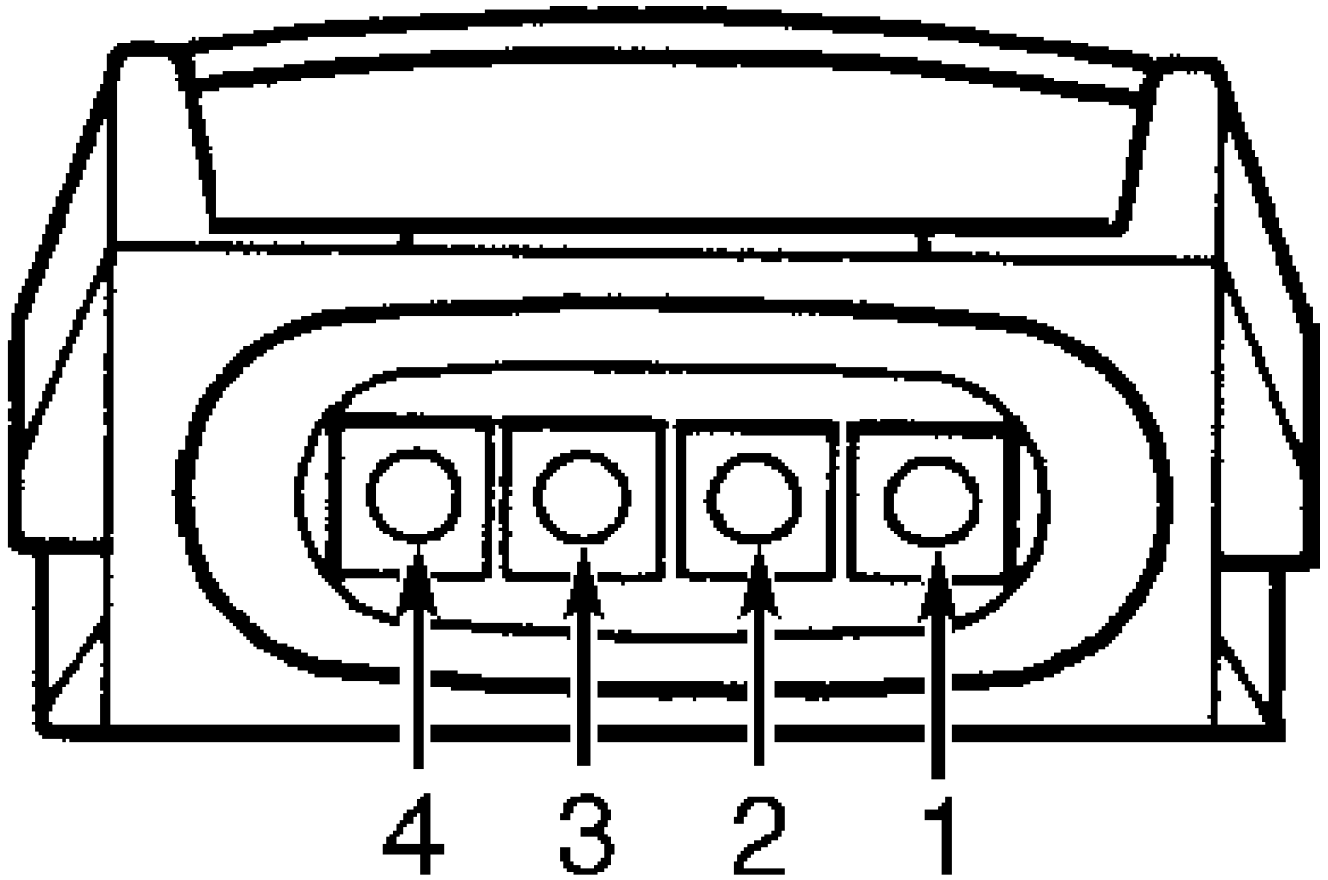

95B34471

Fig. 4: MAF Sensor & Power Stage Connector Terminals  
Courtesy of Volvo Cars of North America.

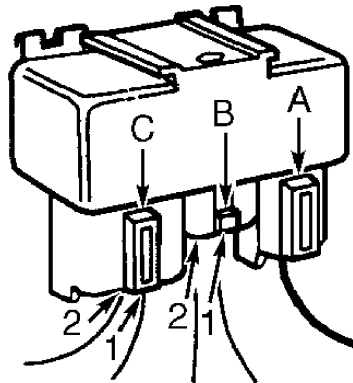

95C34472

Fig. 5: Fan Controlled (FC) Relay Connector Terminals  
Courtesy of Volvo Cars of North America.



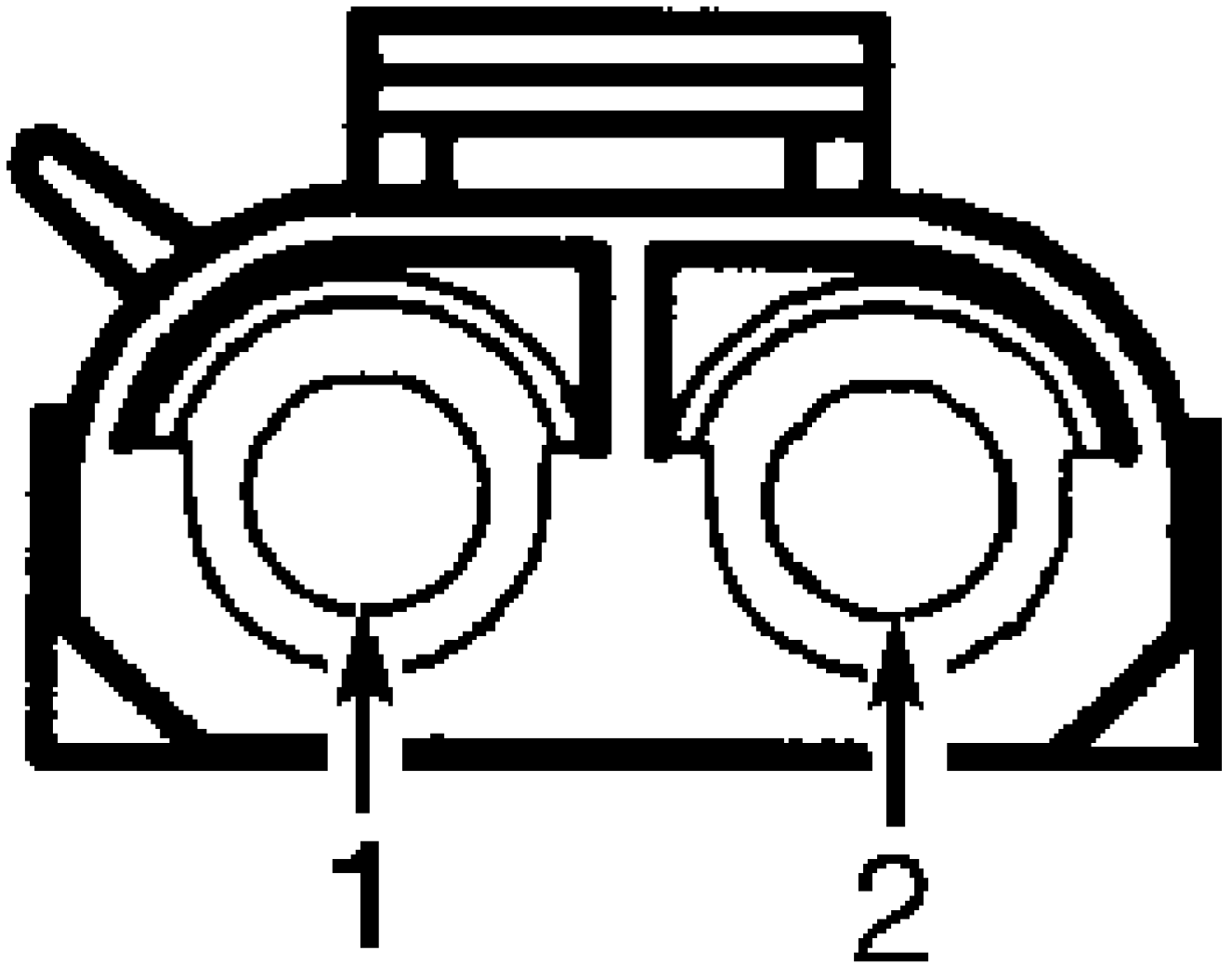

95D34473

Fig. 6: ECT Sensor & EGR Controller Connector Terminals  
 Courtesy of Volvo Cars of North America.

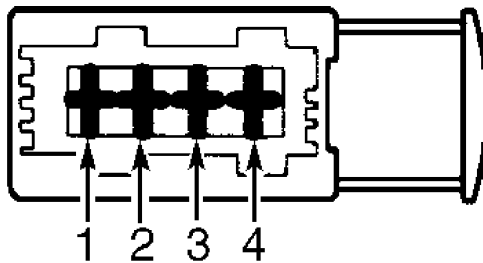

95E34474

Fig. 7: Front & Rear HO2S Connector Terminals  
 Courtesy of Volvo Cars of North America.

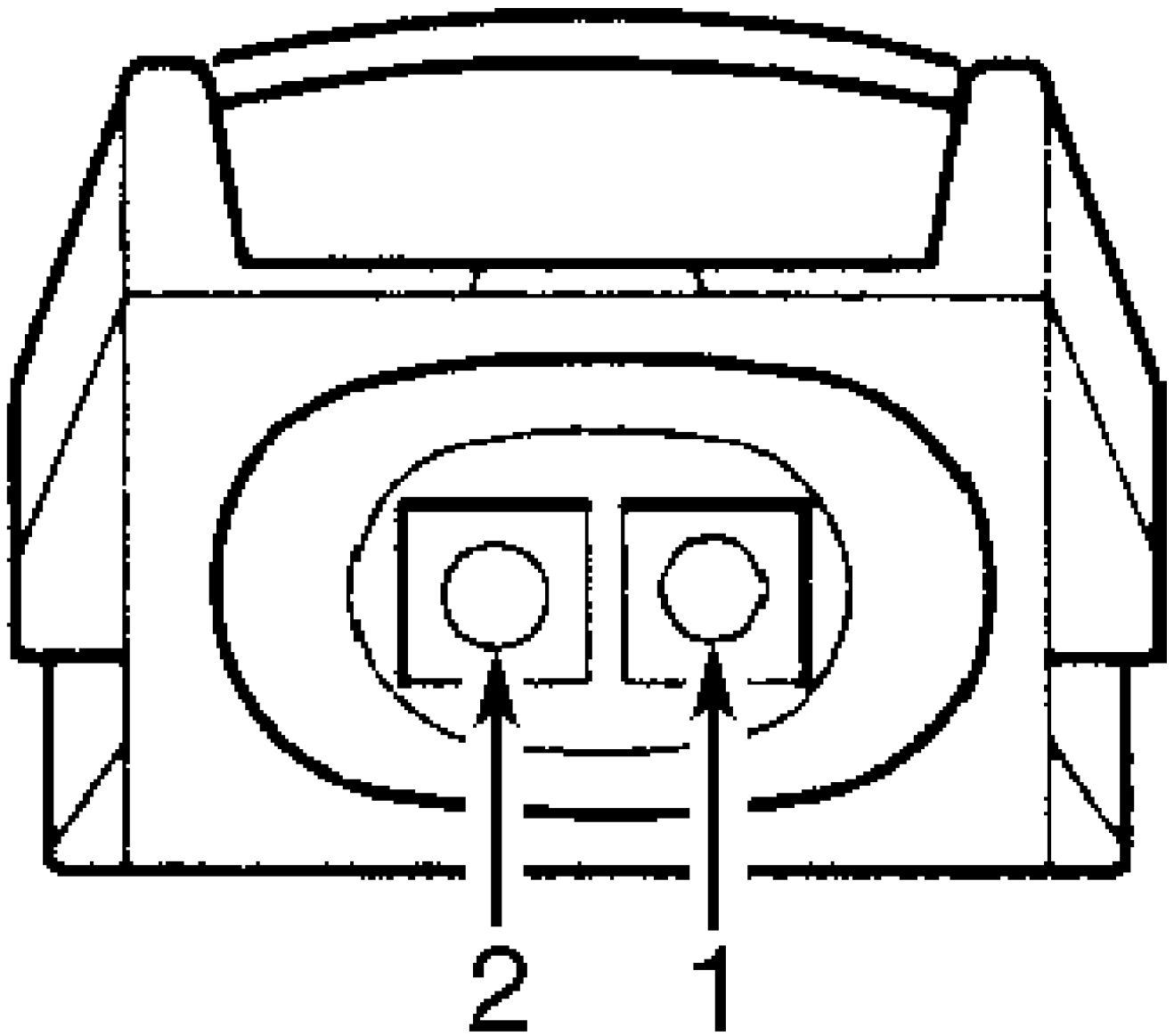

**95F34475**

Fig. 8: EGR Temperature Sensor, EVAP Valve, Fuel Injector, Knock Sensor, RPM Sensor & TC Control Valve Connector Terminals  
 Courtesy of Volvo Cars of North America.

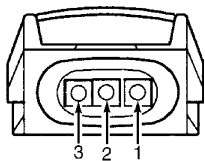

95G34476

Fig. 9: Acceleration Sensor, A/C Pressure Sensor, CMP Sensor, IAC Valve & TP Sensor Connector Terminals  
 Courtesy of Volvo Cars of North America.

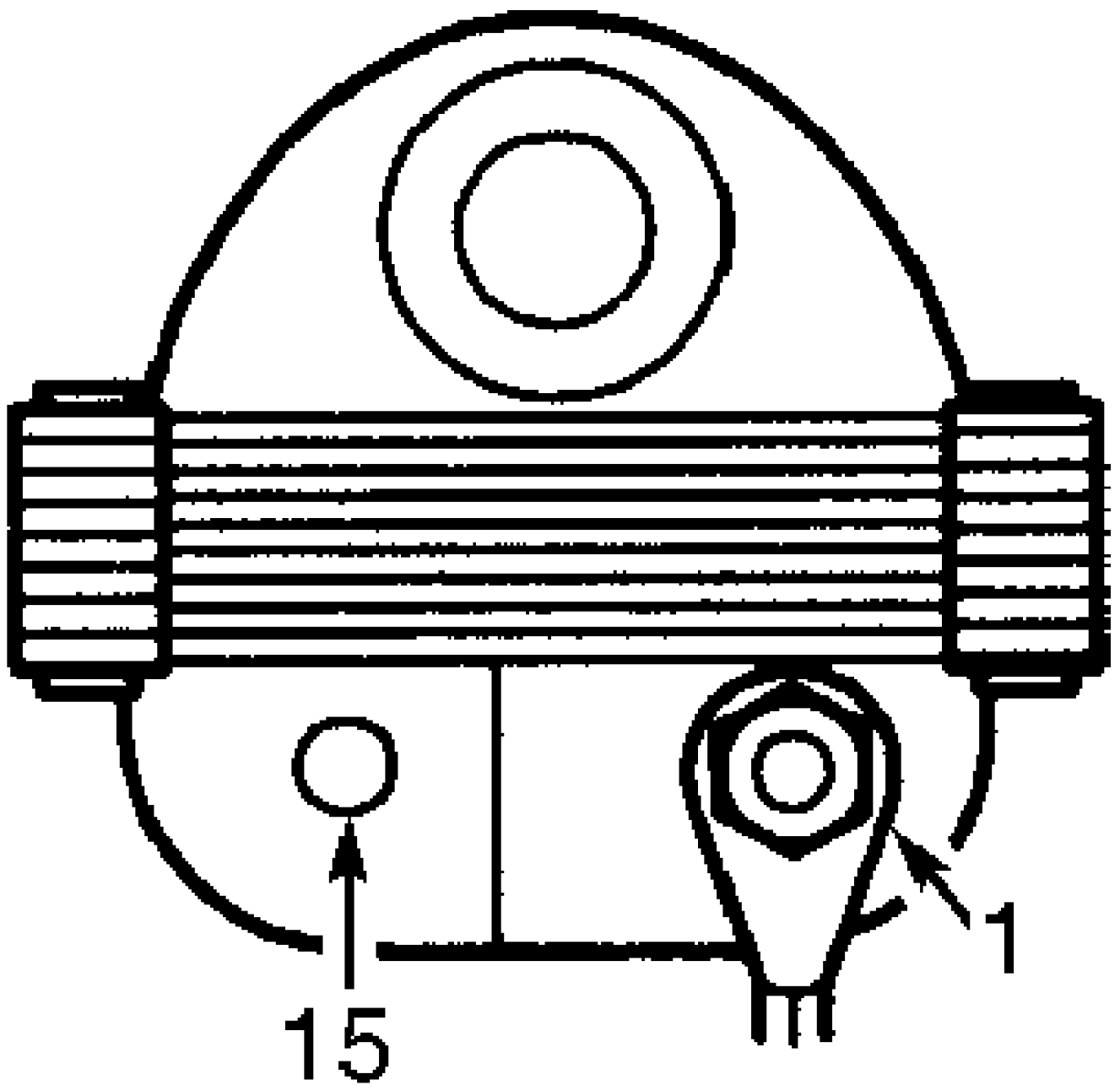

95H34477

Fig. 10: Ignition Coil Connector Terminals  
 Courtesy of Volvo Cars of North America.

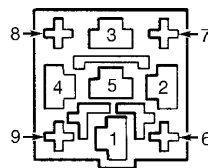

95I34478  
 Fig. 11: Fuel Pump Relay Connector Terminals  
 Courtesy of Volvo Cars of North America.

Code 1-1-2 (Fault In ECM)

1) If ECM detects a fault in ROM/EPROM or RAM memory circuits, circuit for ECM's temperature sensor, knock control circuit, or ECT sensor circuit's NTC coupling, code 1-1-2 is set. If codes 4-3-2 and 5-1-3 are also present, go to testing for those codes. If these codes are not present, go to next step.

2) Clear code. If code reoccurs, replace ECM. If code does not reoccur, fault was intermittent.

Codes 1-1-5, 1-2-5, 1-3-5, 1-4-5 & 1-5-5

(Fuel Injector Problem)

1) If an injector circuit is shorted to ground or voltage, or if there is a break in the circuit, ECM interprets this as a fault and sets code for appropriate injector. If injector signal is too high, check for signal wire shorted to voltage or defective injector. If injector signal is too low, check for signal wire shorted to ground, open circuit in signal or voltage wire, high connector resistance, or defective injector. If fault is permanent, go to next step. If fault is intermittent, go to step 7).

2) To check for an injector signal that is too high, turn ignition off. Disconnect injector connector. Connect ohmmeter between injector connectors No. 1 and 2. If ohmmeter does not indicate about 14.5 ohms, install new injector. If ohmmeter indicates about 14.5 ohms, check wiring between injector connector terminal No. 2 and ECM connector terminal A10 (1-1-5), A38 (1-2-5), A24 (1-3-5), A23 (1-4-5), or A9 (1-5-5) for a short to voltage.

3) To check for an injector signal that is too low, turn ignition off, disconnect injector, and turn ignition on. Connect voltmeter between injector connector terminal No. 1 and ground. If battery voltage is present, go to next step. If battery voltage is not present, check wiring between injector connector terminal No. 1 and main relay connector for an open circuit.

4) Ensure ignition is off. Wait about 90 seconds, then disconnect injector connector. Connect ohmmeter between injector connector terminal No. 2 and ground. If ohmmeter indicates 2500-4000 ohms, go to next step. If ohmmeter indicates infinite resistance, go to step 6). If ohmmeter indicates about zero ohms, check wiring between injector connector terminal No. 2 and ECM terminal A10 (1-1-5), A38 (1-2-5), A24 (1-3-5), A23 (1-4-5), or A9 (1-5-5) for a short to ground.

5) Ensure ignition is off. Disconnect injector connectors. Connect ohmmeter between injector connector terminals No. 1 and 2. If resistance is 14.5 ohms, check for poor contact between injector and/or ECM connector. If resistance is not 14.5 ohms, replace injector.

6) Ensure ignition is off. Disconnect injector connectors. Check connectors for poor contact or oxidation, and repair as necessary. If connector contact is okay, connect an ohmmeter between injector connector terminal No. 2 and ground. If ohmmeter indicates 2500-4000 ohms, check ECM connector for poor contact. If ohmmeter does not indicate 2500-4000 ohms, check wiring between injector connector terminal No. 2 and ECM terminal A10 (1-1-5), A38 (1-2-5), A24(1-3-5), A23 (1-4-5), or A9 (1-5-5) for an open circuit.

7) If fault is intermittent and signal is too high, check wiring between injector connector terminal No. 2 and ECM connector terminal A10(1-1-5), A38 (1-2-5), A24 (1-3-5), A23 (1-4-5), or A9 (1-5-5) for an intermittent short to voltage.

8) If fault is intermittent and signal is too low, check injector and ECM connectors for poor contact or oxidation, and repair as necessary. Also check wiring between injector connector No. 1 and main relay connector for an intermittent open circuit. Check wiring between injector connector No. 2 and ECM terminal A10 (1-1-5), A38 (1-

2-5), A24(1-3-5), A23 (1-4-5), and A9 (1-5-5) for an intermittent short to ground.

#### Code 1-2-1 (MAF Signal)

1) If signal from MAF sensor is less than .2 volt or greater than 2.2 volts at idle, or is considered incorrect according to RPM and throttle angle, this is interpreted by ECM as a fault and code 1-2-1 is set. If fault is permanent and signal is too low, go to step 8). If fault is permanent and signal is too high, go to step 3). If fault is intermittent, go to next step.

2) If fault is intermittent and signal is too high, check all wiring and connectors for loose contacts and open circuits. Also check wiring between MAF sensor connector terminal No. 4 and ECM connector terminal A4 for an intermittent short to voltage. If fault is intermittent and signal is low, ensure all fresh air hoses, and upper and lower charge air cooler pipes are correctly attached. Check wiring between main relay connector terminal No. 3 and MAF sensor connector terminal No. 3 for an intermittent open circuit. Also check wiring between MAF sensor connector terminal No. 4 and ECM connector terminal A4 for an intermittent open or short circuit to ground.

3) Turn ignition off. Wait about 90 seconds and disconnect MAF sensor. Connect ohmmeter between MAF sensor connector terminal No. 1 and ground. If ohmmeter indicates about zero ohms, go to next step. If ohmmeter does not indicate about zero ohms, check wiring between MAF sensor connector terminal No. 1 and ECM terminal A3 for an open circuit.

4) Ensure ignition is off and MAF sensor is disconnected. Connect ohmmeter between MAF sensor connector terminal No. 2 and ground. If ohmmeter indicates about zero ohms, go to step 6). If ohmmeter does not indicate about zero ohms, go to next step.

5) Ensure ignition is off and MAF sensor is disconnected. Ensure ECM connector terminals are not oxidized and make good contact. Reconnect ECM. Connect ohmmeter between MAF sensor connector terminal No. 2 and ground. If ohmmeter indicates about zero ohms, go to next step. If ohmmeter does not indicate about zero ohms, check wiring between MAF sensor connector terminal No. 2 and ECM terminal A5 for an open circuit.

6) Ensure ignition is on and MAF sensor is disconnected. Connect voltmeter between MAF sensor connector terminal No. 4 and ground. If voltmeter indicates 0-1 volt, go to next step. If voltmeter does not indicate 0-1 volt, check wiring between MAF sensor connector terminal No. 4 and ECM connector terminal A4 for a short to voltage. If voltage reading is still incorrect after repair, or short to voltage is not found, replace MAF sensor.

7) Turn ignition off and reconnect MAF sensor. Turn ignition on. Connect voltmeter between MAF sensor connector terminals No. 2 and 4. If voltmeter indicates about .1-.2 volt, code is setting because of poor contact in MAF sensor connector and/or ECM connector. If voltmeter does not indicate about .1-.2 volt, replace MAF sensor.

8) Ensure ignition is off. Ensure fresh air hoses and upper and lower charge air pipes are undamaged and securely connected. If hoses and pipes are okay, disconnect MAF sensor. Turn ignition on. Connect voltmeter between MAF sensor connector terminal No. 3 and ground. If battery voltage is present, go to next step. If battery voltage is not present, check wiring between MAF sensor connector terminal No. 3 and main relay connector terminal No. 3 for an open circuit.

9) Ensure ignition is off. Wait 90 seconds, then disconnect MAF sensor. Connect ohmmeter between MAF sensor connector terminal No. 4 and ground. If ohmmeter indicates 9000-11,000 ohms, go to next step. If ohmmeter shows about zero ohms, check wiring between MAF sensor connector terminal No. 4 and ECM connector terminal A4 for a short to ground. If ohmmeter shows infinite resistance, check wiring between

MAF sensor connector terminal No. 4 and ECM connector terminal A4 for an open circuit.

10) Turn ignition off. Reconnect MAF sensor connector. Turn ignition on. Connect voltmeter between MAF sensor connector terminals No. 4 and 2. If voltmeter shows .1-.2 volt, check for poor contact in MAF sensor connector and/or ECM connector. If voltmeter does not show .1-.2 volt, test system using a known good MAF sensor.

NOTE: Before beginning testing procedure, disconnect engine cooling fan relay connector "A". Code 5-1-4 (engine cooling fan half speed) signal will be set. After testing, reattach connector.

Code 1-2-3 (Engine Coolant Temperature Sensor Signal)

1) If ECM receives a signal from ECT sensor which indicates a temperature less than -49°F (-45°C), or greater than 300°F (150°C), this is interpreted as a fault and DTC 1-2-3 is set.

2) If Codes 3-1-4, 4-1-1, and/or 4-1-3 are set, check ECT sensor, CMP sensor, TP sensor, and EGR temperature sensor joint connector terminal A18 on ECM for signs of contact resistance and/or oxidation. If no other codes are stored, go to next step.

3) If fault is permanent, go to next step. If fault is intermittent and signal is too high, check all connectors for an intermittent open or short circuit to voltage. If fault is intermittent and signal is too low, check wiring between ECT sensor connector terminal No. 1 and ECM terminal A31 for an intermittent short to ground.

4) If fault is permanent and signal is too low, go to step 10). If fault is permanent and signal is too high, turn ignition off. Wait 90 seconds, then disconnect ECT sensor. Connect an ohmmeter between ECT sensor connector No. 2 and ground.

NOTE: Fan run-on must be allowed to finish before taking resistance measurements.

5) If ohmmeter shows about zero ohms, go to next step. If ohmmeter does not show about zero ohms, go to step 7).

6) Turn ignition on. Disconnect ECT sensor connector. Connect voltmeter between ECT sensor connector terminal No. 1 and 2. If voltmeter shows about 5 volts, go to step 8). If voltmeter shows about zero volts, go to step 9). If voltmeter shows more than about 5 volts, check wiring between ECT sensor connector terminal No. 1 and ECM terminal A31 for a short to voltage, then check resistance between ECT sensor terminals. Ohmmeter should show about 2200 ohms. If resistance is incorrect, retest using a known good ECT sensor.

7) Ensure ignition is off. Disconnect ECT sensor connector. Check ECM connector for poor contact and/or oxidation. Reconnect ECM connector. Connect an ohmmeter between ECT sensor connector terminal No. 2 and ground. If ohmmeter shows about zero ohms, code is caused by poor contact in ECM connector. If ohmmeter does not show about zero ohms, check wiring between ECT sensor connector terminal No. 2 and ECM terminal A18 for an open circuit.

8) Ensure ignition is off. Disconnect ECT sensor connector. Connect an ohmmeter between ECT sensor connector terminals No. 1 and 2. If ohmmeter does not show about 2200 ohms, repeat test using a known good ECT sensor. If ohmmeter does show about 2200 ohms, check for poor contact at ECT sensor connector.

9) Ensure ignition is off. Disconnect ECT sensor connector. Ensure ECM connector has good terminal contact. Reconnect ECM connector. Turn ignition on. Connect voltmeter between ECT sensor connector terminals No. 1 and 2. If voltmeter shows about 5 volts, check for poor contact at ECM connector. If voltmeter does not show about 5 volts, check wiring between ECT sensor connector terminal No.

1 and ECM connector terminal A31 for an open circuit.

10) If fault is permanent and signal is too low, turn ignition off. Disconnect ECT sensor. Turn ignition on. Connect voltmeter between ECT sensor connector terminal No. 1 and ground. If voltmeter shows about 5 volts, retest system using a known good ECT sensor. If voltmeter does not show about 5 volts, check wiring between ECT sensor terminal No. 1 and ECM connector terminal A31 for a short to ground.

#### Code 1-3-1 (RPM Sensor Signal Absent)

1) Turn ignition off. Disconnect RPM sensor. Connect an ohmmeter between RPM sensor connector terminals No. 1 and 2. If ohmmeter shows about 200-500 ohms, go to next step. If ohmmeter does not show 200-500 ohms, replace RPM sensor.

2) Turn ignition off. Wait 2 minutes. Ensure RPM sensor is disconnected. Connect an ohmmeter between terminal No. 1 (manual transmission) or terminal No. 2 (automatic transmission) at RPM sensor connector at ECM. If ohmmeter reads about zero ohms, go to step 5). If ohmmeter does not read about zero ohms, go to next step.

3) Turn ignition off. Disconnect RPM sensor connector. Ensure ECM connectors and grounds are clean and tight. Reconnect ECM. Connect an ohmmeter between RPM sensor connector terminal No. 1 (manual transmission) or connector No. 2 (automatic transmission) and ground. If ohmmeter reads about zero ohms, go to next step. If ohmmeter does not read about zero ohms, check wiring between RPM sensor connector No. 1 (manual transmission) or connector No. 2 (automatic transmission) and ECM for an open circuit.

4) Turn ignition off. Disconnect RPM sensor connector at ECM. Connect an ohmmeter between RPM sensor connector terminals No. 1 and 2. If ohmmeter reads 1500-2000 ohms, go to step 6). If ohmmeter shows infinite resistance, go to next step. If ohmmeter shows about zero ohms, check wiring between RPM sensor connector No. 2 (manual transmission) or No. 1 (automatic transmission) and ECM for a short circuit to ground.

5) Turn ignition off. Disconnect ECM connector. Ensure all terminals are clean and tight. Repair as necessary. Reconnect ECM. Disconnect RPM sensor. Connect an ohmmeter between RPM sensor connector terminals No. 1 and 2. If ohmmeter reads 1500-2000 ohms, source of code was poor contact at ECM connector. If ohmmeter does not read 1500-2000 ohms, check wiring between RPM sensor and ECM for an open circuit.

6) Turn ignition on. Disconnect RPM sensor connector. Connect voltmeter between RPM sensor connector terminals. If voltmeter reads 1-2 volts, go to next step. If voltmeter does not read 1-2 volts, check wiring between RPM sensor and ECM for an open circuit or short to voltage.

7) Turn ignition off. Clean RPM sensor connector. Attempt to start engine. If engine starts, reason for code was poor contact in RPM sensor connector and/or ECM connector. If engine does not start, check connecting flange/flywheel for possible damage and scratches through sensor's holes. If no problem is found on connecting flange/flywheel, test using new RPM sensor.

#### Code 1-3-2 (Battery Voltage Signal Too Low Or Too High)

1) If fault is permanent and voltage is too high, check charging system for signs of excessive charge. If fault is intermittent, and voltage is too high, replace voltage regulator.

2) If fault is permanent and voltage is too low, operate engine at idle. Connect voltmeter to battery. If voltmeter reads 12-15 volts, check wiring between battery and ECM terminal A27 for an open circuit. If voltmeter does not read 12-15 volts, check charging system. See ON-VEHICLE TESTING in the ALTERNATOR & REGULATOR article in the ELECTRICAL section. If voltmeter does read 12-15 volts, check

wiring between battery and ECM for connector resistance.

3) If fault is intermittent and voltage is too low, check all ECM and main relay wiring and connectors for looseness and and/or contact resistance.

Code 1-4-3 (Front Knock Sensor Signal) &  
Code 4-3-3 (Rear Knock Sensor Signal)

1) If fault is intermittent, check camshaft setting. See the 2.3L article in the ENGINES section. If camshaft setting is okay, check all wiring and connectors for poor contact. If fault is permanent, go to next step.

2) Turn ignition off. Check camshaft setting in relation to crankshaft. Repair as necessary. If camshaft setting is okay, gain access to knock sensor(s) by removing upper charge air cooler pipe and engine cooling fan. To gain access to rear knock sensor also remove intake manifold support bracket.

3) Ensure ignition is still off. Wait 2 minutes. Disconnect knock sensor. Connect an ohmmeter between knock sensor connector terminal No. 2 and ground. If ohmmeter reads about zero ohms, go to step 5). If ohmmeter does not read about zero ohms, go to next step.

4) Ensure ignition is still off and knock sensor is disconnected. Ensure ECM connector is making good electrical contact and is connected securely to ECM. Connect an ohmmeter between knock sensor connector terminal No. 2 and ground. If ohmmeter reads about zero ohms, code was caused by poor contact in ECM connector. If ohmmeter does not read about zero ohms, check wiring between knock sensor connector terminal No. 2 and ECM connector terminal A17 for an open circuit.

5) Ensure ignition is still off and knock sensor is disconnected. Connect an ohmmeter between knock sensor connector terminal No. 1 and ground. If ohmmeter reads about zero ohms, check wiring between knock sensor connector terminal No. 1 and ECM connector terminal A2 (Code 1-4-3) or terminal A30 (4-3-3) for short to ground. If ohmmeter reads about one megohm, go to step 7). If ohmmeter reads infinite resistance, go to next step.

6) Ensure ignition is still off and knock sensor is disconnected. Ensure ECM connector terminals are free of resistance and oxidation. Reconnect ECM. Connect an ohmmeter between knock sensor connector terminal No. 1 and ground. If ohmmeter reads about one megohm, code is caused by poor contact in ECM's connector. If ohmmeter does not read about one megohm, check wiring between knock sensor connector terminal No. 1 and ECM terminal A2 (Code 1-4-3) or terminal A30 (Code 4-3-3) for an open circuit.

7) Reconnect knock sensor(s). Start and warm up engine. Increase engine speed to slightly greater than 3500 RPM. Use Volvo Scan Tool (998-8686) to check knock sensor value. If knock sensor value is 2-6 at speeds greater than 3500 RPM, source of code is poor contact at knock sensor connector. If knock sensor value is not 2-6 at speeds greater than 3500 RPM, test system using a new knock sensor.

Code 1-5-3 (Rear HO2S Signal)

1) If Codes 5-2-2 or 2-1-2 are stored, perform diagnosis for these codes first. If fault is permanent or intermittent and signal is too high, perform diagnosis as per Code 2-1-2. If fault is permanent and signal is too low, go to next step. If fault is permanent and signal is faulty, go to step 8). If fault is intermittent and signal is too low, go to step 9). If fault is intermittent and signal is faulty, go to step 10).

2) Turn ignition off. Wait 2 minutes. Disconnect rear HO2S Gray connector. Connect an ohmmeter between HO2S connector terminal No. 4 and ground. If ohmmeter shows about 100 k/ohms, go to step 4). If ohmmeter shows infinite resistance, go to next step. If ohmmeter shows about zero ohms, check wiring between rear HO2S connector



terminal No. 4 and ECM terminal A34 for a short circuit to ground.

3) Turn ignition off. Disconnect HO2S connector. Ensure ECM connector terminal contacts are clean and tight. Reconnect ECM. Connect an ohmmeter between HO2S connector terminal No. 4 and ground. If ohmmeter reads about 100 k/ohms, source of code is poor contact at ECM connector. If ohmmeter does not read about 100 k/ohms, check wiring between rear HO2S connector terminal No. 4 and ECM terminal A34 for an open circuit.

4) Turn ignition off. Disconnect rear HO2S connector. Connect an ohmmeter between HO2S connector terminal No. 3 and ground. If ohmmeter reads about 200 ohms, go to step 7). If ohmmeter shows infinite resistance, go to next step. If ohmmeter shows about zero ohms, go to step 6).

5) Turn ignition off. Disconnect rear HO2S connector. Ensure ECM connector terminals are clean and tight. Reconnect ECM. Connect an ohmmeter between HO2S connector terminal No. 3 and ground. If ohmmeter reads about 200 ohms, source of code is poor contact in ECM connector. If ohmmeter does not read about 200 ohms, check wiring between rear HO2S connector terminal No. 3 and ECM terminal A19 for an open circuit.

6) Turn ignition off. Disconnect rear HO2S connector. Disconnect front HO2S Black connector. Connect an ohmmeter between rear HO2S connector terminal No. 3 and ground. If ohmmeter reads about 200 ohms, test system using a new front HO2S. If ohmmeter does not read about 200 ohms, check wiring between front HO2S connector terminal No. 3 and ECM terminal A33, and wiring between rear HO2S connector terminal No. 3 and ECM terminal A19 for a short to ground.

7) Turn ignition off. Ensure rear HO2S is connected. Start and run engine at idle. Check voltage at rear HO2S. Voltage signal should have left its bottom setting (-.165 volt) and stabilized between .1-.9 volt within about 10 minutes. If reading is okay, source of code is poor contact at rear HO2S connector. If reading is not okay, retest using new rear HO2S.

8) If fault is permanent and signal is faulty, turn ignition off. Wait about 2 minutes. Disconnect rear HO2S Gray connector. Connect an ohmmeter between HO2S connector terminals No. 3 and 4. If ohmmeter reads infinite resistance, check wiring between rear HO2S connector terminal No. 4 and ECM connector terminal A34 for a short circuit to rear HO2S connector terminal No. 3 and ECM connector terminal A19. If ohmmeter does not read infinite resistance, test using new HO2S.

9) If fault is intermittent and signal is too low, check wiring between rear HO2S connector terminal No. 4 and ECM terminal A34, and between rear HO2S connector terminal No. 3 and ECM terminal A19 for an open circuit. Check ECM and rear HO2S connector for loose connection. Check wiring between rear HO2S connector terminal No. 4 and ECM terminal A34 for an intermittent short circuit to ground. Also check wiring between front HO2S connector terminal No. 3 and ECM terminal A33, and wiring between rear HO2S connector terminal No. 3 and ECM terminal A19 for an intermittent short circuit to ground.

10) If fault is intermittent and signal is faulty, check wiring between rear HO2S connector terminal No. 4 and ECM connector terminal A34 for an intermittent short circuit of wire between rear HO2S connector terminal No. 3 and ECM connector A19.

#### Code 1-5-4 (EGR System Leakage)

1) Start and run engine at idle. If engine runs unevenly at idle, go to next step. If engine runs smoothly at idle, fault is intermittent. Go to step 5).

2) Operate engine at idle. Disconnect EGR connector. If engine still runs unevenly, go to next step. If engine now runs smoothly, check wiring between EGR controller connector terminal No. 1 and ECM terminal A40 for a short to ground.

3) Operate engine at idle. Carefully remove Yellow hose from EGR controller. If engine still runs unevenly, go to next step. If engine now runs smoothly, test system using new EGR controller.

4) Operate engine at idle. Carefully remove Yellow hose from EGR valve. If engine still runs unevenly at idle, test system using a new EGR valve. If engine now runs smooth at idle, check if Yellow hose is blocked or kinked. Replace as necessary.

5) Check wiring between EGR controller connector terminal No. 2 and ECM connector terminal A40 for possible intermittent short circuits to ground. Ensure EGR controller is operating. Ensure EGR valve is not sticking.

#### Code 2-1-2 (Front HO2S Signal)

1) Check for other codes. If Code 5-2-1 is stored, diagnose that code first. If Code 5-2-1 is not stored, go to next step.

2) If fault is permanent and signal is too high, go to next step. If fault is permanent and signal is too low, go to step 9). If fault is permanent and signal is absent, go to step 13). If fault is permanent and signal is faulty, go to step 19). If fault is intermittent and signal is too high, go to step 20). If fault is intermittent and signal is too low, go to step 21). If fault is intermittent and signal is absent, go to step 22). If fault is intermittent and signal is faulty, go to step 23).

3) Turn ignition off. Connect breakout box between ECM and ECM connector. Turn ignition on. Connect voltmeter between breakout box pins No. 33 and 42. If voltmeter reads about .7 volt, go to step 6). If voltmeter does not read about .7 volt, go to next step.

4) Turn ignition off. Disconnect front HO2S Black connector. Turn ignition on. Connect voltmeter between breakout box pins No. 33 and 42. If voltmeter reads about .7 volt, retest using new front HO2S. If voltmeter does not read about .7 volt, go to next step.

5) Turn ignition off. Disconnect front HO2S connector. Disconnect rear HO2S Gray connector. Turn ignition on. Connect voltmeter between breakout box pins No. 33 and 42. If voltmeter reads about .7 volt, test using new rear HO2S. If voltmeter does not read about .7 volt, check wiring between front HO2S connector terminal No. 3 and ECM terminal A33, and wiring between rear HO2S connector terminal No. 3 and ECM terminal A19 for a short to voltage.

6) Turn ignition on. Connect voltmeter between breakout box pins No. 32 and 42. If voltmeter reads about 1.2 volts, go to step 8). If voltmeter does not read about 1.2 volts, go to next step.

7) Turn ignition off. Disconnect front HO2S Black connector. Turn ignition on. Connect voltmeter between breakout box pins No. 32 and 42. If voltmeter reads about 1.2 volts, test using new front HO2S. If voltmeter does not read about 1.2 volts, check wiring between front HO2S connector terminal No. 4 and ECM terminal A32 for a short to voltage.

8) Turn ignition off. Disconnect rear HO2S Gray connector. Turn ignition on. Connect voltmeter between breakout box pins No. 34 and 42. If voltmeter reads about zero volts, test using a new rear HO2S. If voltmeter does not read about zero volts, check wiring between rear HO2S connector terminal No. 4 and ECM terminal A34 for a short to voltage.

9) If fault is permanent and signal is too low, connect breakout box to ECM. Turn ignition on. Connect voltmeter between breakout box pins No. 33 and 42. If voltmeter reads about .7 volt, go to step 12). If voltmeter does not read about .7 volt, go to next step.

10) Turn ignition off. Disconnect front HO2S Black connector. Turn ignition on. Connect voltmeter between breakout box pins No. 33 and 42. If voltmeter reads about .7 volt, test using new front HO2S. If voltmeter does not read about .7 volt, go to next step.

11) Turn ignition off. Disconnect front HO2S Black connector.

Disconnect rear HO2S Gray connector. Turn ignition on. Connect voltmeter between breakout box pins No. 33 and 42. If voltmeter reads about .7 volt, test using new rear HO2S. If voltmeter does not read about .7 volt, check wiring between front HO2S connector terminal No. 3 and ECM terminal A33, and wiring between rear HO2S connector terminal No. 3 and ECM terminal A19 for a short circuit to ground.

12) Turn ignition off. Disconnect front HO2S Black connector. Turn ignition on. Connect voltmeter between breakout box pins No. 32 and 42. If voltmeter reads about 1.2 volts, test using new front HO2S. If voltmeter does not read about 1.2 volts, check wiring between front HO2S connector terminal No. 4 and ECM terminal A32 for a short circuit to ground.

13) If fault is permanent and signal is absent, turn ignition off. Wait about 2 minutes. Disconnect front HO2S Black connector. Connect an ohmmeter between HO2S connector terminal No. 4 and ground. If ohmmeter reads about 50 k/ohms, go to step 15). If ohmmeter reads infinite resistance, go to next step. If ohmmeter reads about zero ohms, check wiring between front HO2S connector terminal No. 4 and ECM terminal A32 for a short circuit to ground.

14) Turn ignition off. Disconnect ECM. Disconnect front HO2S connector. Ensure ECM connector terminals are clean and tight. Reconnect ECM. Connect ohmmeter between HO2S connector terminal No. 4 and ground. If ohmmeter reads about 50 k/ohms, cause of code is poor contact at ECM connector. If ohmmeter does not read about 50 k/ohms, check wiring between front HO2S connector terminal No. 4 and ECM terminal A32 for an open circuit.

15) Turn ignition off. Disconnect front HO2S connector. Connect an ohmmeter between HO2S terminal No. 3 and ground. If ohmmeter reads infinite resistance, go to next step. If ohmmeter reads about zero ohms, go to step 17). If ohmmeter reads 200 ohms, go to step 18).

16) Turn ignition off. Disconnect ECM. Disconnect front HO2S connector. Ensure ECM connector terminals are clean and tight. Reconnect ECM connector. Connect an ohmmeter between HO2S connector terminal No. 3 and ground. If ohmmeter reads about 200 ohms, source of code was poor contact in ECM connector. If ohmmeter does not read about 200 ohms, check wiring between front HO2S connector terminal No. 3 and ECM connector terminal A33 for an open circuit.

17) Turn ignition off. Disconnect front HO2S Gray connector. Connect ohmmeter between front HO2S connector terminal No. 3 and ground. If ohmmeter reads about 200 ohms, retest using new rear HO2S. If ohmmeter does not read about 200 ohms, check wiring between front HO2S connector terminal No. 3 and ECM connector terminal A33, and wiring between rear HO2S connector terminal No. 3 and ECM connector terminal A19 for a short to ground.

18) Turn ignition off. Ensure front HO2S is connected. Start and run engine at idle. Front HO2S should shift from its middle setting (.45 volt), and begin to vary between .1-.9 volt within minutes. If reading is okay, cause of code is poor contact in front HO2S connector. Ensure connector tabs are not damaged. If reading is incorrect, retest using new front HO2S.

19) If fault is permanent and signal is faulty, turn ignition off. Wait about 2 minutes. Disconnect front HO2S Black connector. Connect an ohmmeter between HO2S connector terminals No. 3 and 4. If ohmmeter reads 50 ohms to infinite resistance, check wiring between front HO2S connector terminal No. 4 and ECM connector terminal A32 for a short circuit in wiring between front HO2S connector terminal No. 3 and ECM terminal A33. If ohmmeter does not read 50 to infinite ohms, test using new front HO2S.

20) If fault is intermittent and signal is too high, check wiring between front HO2S connector terminal No. 4 and ECM connector terminal A32 for an intermittent short circuit to voltage. Also check wiring between front HO2S connector terminal No. 3 and ECM connector

terminal A33, between rear HO2S connector terminal No. 3 and ECM terminal A19, and between rear HO2S connector terminal No. 4 and ECM terminal A34 for intermittent short to voltage.

21) If fault is intermittent and signal is too low, check wiring between front HO2S connector terminal No. 4 and ECM terminal A32, between front HO2S connector terminal No. 3 and ECM terminal A33, and between rear HO2S connector terminal No. 3 and ECM terminal A19 for an intermittent short to ground.

22) If fault is intermittent and signal is absent, check wiring between front HO2S connector terminal No. 4 and ECM terminal A32, and wiring between front HO2S connector terminal No. 3 and ECM terminal A33 for an intermittent open circuit. Check front HO2S and ECM connectors for a loose connection. Check wiring between front HO2S connector terminal No. 4 and ECM terminal A32, wiring between front HO2S connector terminal No. 3 and ECM terminal A33, and wiring between rear HO2S connector terminal No. 3 and ECM terminal A19 for an intermittent short circuit to ground.

23) If fault is intermittent and signal is faulty, check wiring between front HO2S connector terminal No. 4 and ECM terminal A32 for an intermittent short circuit between front HO2S connector terminal No. 3 and ECM terminal A33.

Code 2-1-4 (RPM Sensor Signal Sporadic)

1) Check RPM sensor and ECM connectors for loose connection, contact resistance and oxidation. Repair as necessary. Check wiring for short circuit to ground or voltage.

2) If all wiring and connections are okay, check connecting flange/flywheel through sensor hole for damage and scratches. If no damage is present, retest using new RPM sensor.

Code 2-2-3 (Valve Signal Opening) or

Code 2-4-5 (Valve Signal Closing)

1) If fault is permanent and signal is too high, go to next step. If fault is permanent and signal is too low, go to step 4). If fault is intermittent and signal is too high, go to step 8). If fault is intermittent and signal is too low, go to step 9).

2) Turn ignition off. Disconnect IAC valve. Turn ignition on. Connect voltmeter between ground and IAC valve connector terminal No. 3 (Code 2-2-3) or terminal No. 1 (Code 2-4-5). If voltmeter shows less than one volt, go to next step. On Code 2-2-3, if voltmeter shows more than one volt, check wiring between IAC valve connector terminal No. 3 and ECM terminal A11 for a short circuit to voltage. On Code 2-4-5, if voltmeter shows more than one volt, check wiring between IAC valve connector terminal No. 1 and ECM terminal A25 for a short circuit to voltage.

3) Turn ignition off. Wait about 2 minutes. Disconnect IAC valve. Connect an ohmmeter between IAC valve connector terminals No. 1 and 3. If ohmmeter reads 20-40 k/ohms, test using new IAC valve. If ohmmeter shows about zero ohms, check wiring between IAC valve connector terminal No. 3 and ECM terminal A11 for a short circuit to wiring between IAC valve connector terminal No. 1 and ECM terminal A25. If IAC valve signal wiring is shorted to each other, then both Codes 2-2-3 and 2-4-5 will be set.

4) If fault is permanent and signal is too low, turn ignition off. Disconnect IAC valve. Turn ignition on. Connect voltmeter between IAC valve connector terminal No. 2 and ground. If voltmeter shows battery voltage, go to next step. If voltmeter does not show battery voltage, check wiring between main relay connector terminal No. 3 and IAC valve connector terminal No. 2 for an open circuit. If there is an open circuit in voltage lead, both Codes 2-2-3 and 2-4-5 will be set.

5) Turn ignition off. Wait about 2 minutes. Disconnect IAC valve connector. Connect an ohmmeter between ground and IAC valve connector terminal No. 3 (Code 2-2-3) or No. 1 (Code 2-4-5). If

ohmmeter reads 10-20 k/ohms, go to step 7). If ohmmeter reads infinite resistance, go to next step. If ohmmeter shows about zero ohms, on Code 2-2-3, check wiring between IAC valve connector terminal No. 3 and ECM terminal A11 for a short circuit to ground. On Code 2-4-5, check wiring between IAC valve connector terminal No. 1 and ECM terminal A25 for a short to ground.

6) Turn ignition off. Disconnect IAC valve connector. Ensure ECM connector terminals are clean and tight, and free of oxidation. Reconnect ECM connector. Connect an ohmmeter between ground and IAC valve connector terminal No. 3 (Code 2-2-3) or terminal No. 1 (Code 2-4-5). If ohmmeter reads 10-20 k/ohms, cause of code was poor contact in ECM connector. If ohmmeter does not show 10-20 k/ohms, on Code 2-2-3, check wiring between IAC valve connector terminal No. 3 and ECM terminal A11 for an open circuit. On Code 2-4-5, check wiring between IAC valve connector terminal No. 1 and ECM terminal A25 for an open circuit.

7) Turn ignition off. Disconnect IAC valve. Connect ohmmeter between IAC valve connector terminals No. 1 and 2, then between terminals No. 2 and 3. If ohmmeter reads 9-14 ohms in both cases, cause of code is poor contact in IAC valve connector. Repair as necessary. If ohmmeter does not read 9-14 ohms in both cases, test using new IAC valve.

8) If fault is intermittent and signal is too high, on Code 2-2-3, check wiring between IAC valve connector terminal No. 3 and ECM terminal A11 for an intermittent short to voltage or intermittent short circuit to coil signal voltage. On Code 2-4-5, check wiring between IAC valve connector terminal No. 1 and ECM terminal A25 for an intermittent short to voltage or intermittent short circuit to coil signal voltage.

9) If fault is intermittent and signal is too low on Code 2-4-5, go to next step. On Code 2-2-3, check IAC valve and ECM connectors for contact resistance and oxidation. Repair as necessary. Check wiring between main relay connector terminal No. 3 and IAC valve connector terminal No. 2 for an intermittent open circuit. Also check wiring between IAC valve connector terminal No. 3 and ECM terminal A11 for an intermittent open circuit or short circuit to ground.

10) On Code 2-4-5, check IAC valve and ECM connectors for contact resistance and oxidation. Repair as necessary. Check wiring between main relay connector terminal No. 3 and IAC valve connector terminal No. 2 for an intermittent open circuit. Also check wiring between IAC valve connector terminal No. 1 and ECM terminal A25 for an intermittent open circuit or short circuit to ground.

#### Code 2-2-5 (A/C Pressure Sensor Signal)

1) If fault is permanent and signal is too high, go to next step. If fault is permanent and signal is too low, go to step 7). If fault is intermittent and signal is too high, go to step 8). If fault is intermittent and signal is too low, go to step 9).

2) Turn ignition off. Wait about 2 minutes. Disconnect A/C pressure sensor. Connect an ohmmeter between A/C pressure sensor connector terminal No. 1 and ground. If ohmmeter reads about zero ohms, go to step 4). If ohmmeter does not read about zero ohms, go to next step.

3) Turn ignition off. Disconnect A/C pressure sensor connector. Check ECM connector for oxidation and poor terminal contact. Repair as necessary. Reconnect ECM connector. Connect an ohmmeter between A/C pressure sensor connector terminal No. 1 and ground. If ohmmeter reads about zero ohms, go to next step. If ohmmeter does not read about zero ohms, check wiring between A/C pressure sensor connector terminal No. 1 and ECM terminal B28 for an open circuit.

4) Turn ignition on. Disconnect A/C pressure sensor connector. Connect a voltmeter between A/C pressure sensor connector

terminal No. 2 and ground. If voltmeter reads about 5 volts, go to step 6). If voltmeter reads about zero volts, go to next step. If voltmeter reads more than about 5 volts, check wiring between A/C pressure sensor connector terminal No. 2 and ECM terminal B9 for a short to voltage.

5) Turn ignition off. Disconnect A/C pressure sensor. Ensure ECM connector terminals are clean and free of oxidation. Repair as necessary. Reconnect ECM. Turn ignition on. Connect voltmeter between A/C pressure sensor connector terminal No. 2 and ground. If voltmeter reads about 5 volts, cause of code is poor contact in ECM connector. If voltmeter does not read about 5 volts, check wiring between A/C pressure sensor connector terminal No. 2 and ECM terminal B9 for an open circuit.

6) Turn ignition off. Reconnect A/C pressure sensor. Start engine and idle for 15 seconds. Turn A/C and blower on. If A/C APPROVED parameter displays YES on Volvo Scan Tool (998-8686), cause of code is poor contact in A/C pressure sensor connector. If parameter displays NO, retest using new A/C pressure sensor.

7) If fault is permanent and signal is too low, turn ignition off. Disconnect A/C pressure sensor. Turn ignition on. Connect voltmeter between A/C pressure sensor connector terminal No. 2 and ground. If voltmeter reads about 5 volts, retest using new A/C pressure sensor. If voltmeter does not read about 5 volts, check wiring between A/C pressure sensor connector terminal No. 2 and ECM terminal B9 for a short circuit to ground.

8) If fault is intermittent and signal is too high, check A/C pressure sensor and ECM connectors for loose connection or contact resistance. Check wiring between A/C pressure sensor connector terminal No. 1 and ECM terminal B28 for an intermittent open circuit. Also check wiring between A/C pressure sensor connector terminal No. 2 and ECM terminal B9 for an intermittent open circuit or short circuit to ground.

9) If fault is intermittent and signal is too low, check wiring between A/C pressure sensor connector terminal No. 2 and ECM terminal B9 for an intermittent short circuit to ground. Repair as necessary.

Code 2-3-1 (Long Term Fuel Trim Partial Load) Or

Code 2-3-2 (Long Term Fuel Trim Idling)

1) Check for other codes. If Code 3-1-5 is stored, perform testing on that code first. If Code 3-1-5 is not stored, go to next step.

2) Check status message on Volvo Scan Tool (998-8686). If status message reads LOWER LIMIT, go to step 8). If status message reads UPPER LIMIT, go to next step.

3) Turn ignition on. Connect voltmeter between MAF sensor connector terminals No. 2 and 4. If voltmeter reads .1-.2 volt, go to next step. If voltmeter does not read .1-.2 volt, test using new MAF sensor.

4) Check for air leakage in intake system. Repair as necessary. If air leakage in intake system is not present, go to next step.

5) Check for air leakage in exhaust system. If there is no air leakage, go to next step. If there is air leakage, repair as necessary.

6) Check fuel and residual pressure. If fuel and residual pressure are okay, go to next step. If fuel and residual pressure are not okay, repair as necessary.

7) Connect breakout box to ECM and check ground connections. See COMPUTERIZED ENGINE CONTROLS in I - SYSTEM/COMPONENT TESTS article. Reconnect ECM. Repair as necessary.

8) If status message reads LOWER LIMIT, turn ignition on. Connect voltmeter between MAF sensor connectors terminals No. 2 and 4.

If voltmeter reads .1-.2 volt, go to next step. If voltmeter does not read .1-.2 volt, test using new MAF sensor.

9) Check for air leakage in intake and exhaust system. Repair as necessary. Check fuel and residual pressure. Repair as necessary. If no air leakage and fuel and residual pressure are okay, go to next step.

10) Remove hose leading to intake manifold from EVAP valve. Connect vacuum pump to EVAP valve coupling. If vacuum gauge does not show stable vacuum, repair as necessary. If vacuum gauge does show stable vacuum, go to next step. Check engine oil and fill as necessary.

11) Start engine and run at idle a few minutes. Using Volvo Scan Tool (998-8686), read off value on SHORT TERM FUEL TRIM and note value. Disconnect and plug crankcase ventilation. Read off value of short term fuel trim once again. If value is more or less unchanged, go to next step. If value rises, engine oil is diluted with fuel. Repair as necessary.

12) Connect breakout box to ECM connector and check grounds. Connect ECM. Check all signals to and from ECM. Repair as necessary.

#### Code 2-3-3 (Idle Air Trim)

1) If Volvo Scan Tool (998-8686) reads UPPER LIMIT, go to next step. If scan tool reads LOWER LIMIT, go to step 7).

2) Operate engine at idle. Read off throttle position on scan tool. If throttle position is 3-8 degrees with throttle shut, go to next step. If throttle position is not 3-8 degrees with throttle shut, repair as necessary.

3) Turn ignition off. Ensure air cleaner, air intake, and hoses and pipes between air cleaner and throttle body are not blocked. Also check connectors for IAC valve. If all components are okay, go to next step. If all components are not okay, repair as necessary.

4) Turn ignition off. Disconnect IAC valve. Connect an ohmmeter between IAC connector terminals No. 1 and 3. If ohmmeter reads 18-28 ohms, go to next step. If ohmmeter does not read 18-28 ohms, retest using new IAC valve.

5) Turn ignition off. Remove IAC valve. Hold valve at connector. Turn valve quickly (but carefully) back and forth. Listen for sound of slide striking.

CAUTION: To prevent scratching and damage, do not touch slide with a screwdriver or similar tool.

6) If slide in IAC valve strikes, clean IAC valve and ECM connectors of oxidation or other contact resistance. If slide does not strike, retest using new IAC valve.

7) Run engine at idle. Using Volvo Scan Tool (998-8686), read off throttle position. If throttle position is 3-8 degrees with throttle closed, go to next step. If throttle position is not 3-8 degrees with throttle closed, adjust throttle angle.

8) Turn ignition off. Check IAC valve and related components for air leakage. Repair as necessary. If no air leakage is present, go to next step.

9) Turn ignition off. Disconnect IAC valve. Connect an ohmmeter between IAC valve connector terminal No. 1 and 3. If ohmmeter reads 18-28 ohms, go to next step. If ohmmeter does not read 18-28 ohms, retest using new IAC valve.

10) Turn ignition off. Remove IAC valve. Hold valve at connector. Turn valve quickly (but carefully) back and forth. Listen for sound of slide striking.

CAUTION: To prevent scratching and damage, do not touch slide with a screwdriver or similar tool.

11) If slide in IAC valve strikes, clean IAC valve and ECM connectors of oxidation or other contact resistance. If slide does not strike, retest using new IAC valve.

Code 2-4-1 (EGR System, Flow Malfunction)

1) Turn ignition on. Use Volvo Scan Tool (998-8686) parameter Diagnostic Test Mode No. 3 and check EGR controller functions. If EGR controller operates, go to next step. If EGR controller does not operate, go to step 7).

2) Turn ignition off. Disconnect wire at EGR controller connector terminal No. 2. Connect a jumper wire between EGR controller connector terminal No. 2 and ground. Start engine and run at idle. If engine runs unevenly at idle, fault is intermittent. Go to step 11). If engine does not run unevenly at idle, go to next step.

3) Turn ignition off. Carefully remove White hose from EGR controller. Connect vacuum gauge to White hose. Start and run engine at idle. If vacuum gauge gives any reading, go to next step. If vacuum gauge does not give a reading, ensure White vacuum hose and connection to intake manifold are not blocked.

4) Start and run engine at idle. Connect White hose to EGR controller. Carefully disconnect Yellow hose from EGR controller. Connect a vacuum gauge to EGR controller connector. Connect loose wire on EGR controller to ground so as to open EGR controller. If vacuum gauge gives any reading, go to next step. If vacuum gauge does not give a reading, retest using new EGR controller.

5) Turn ignition off. Carefully disconnect Yellow hose from EGR valve. Check Yellow hose for leaks or obstruction. Repair as necessary. If hose is okay, go to next step.

6) Turn ignition off. Connect Yellow hose to EGR valve. Connect vacuum pump to Yellow hose at EGR controller. Start engine and run at idle. Pump vacuum to maximum of 4.35 psi (30 kPa). Check that EGR valve retains vacuum. Engine should run unevenly when vacuum pump shows negative pressure. If engine runs evenly when vacuum pump shows negative pressure but vacuum pump loses vacuum, test using new EGR valve. If engine runs smoothly at idle when vacuum pump shows negative pressure and vacuum pump retains vacuum, check if EGR pipe is clogged. Repair as necessary. If EGR pipe is okay, retest using new EGR valve.

7) If EGR controller does not operate, turn ignition off. Disconnect EGR controller connector. Turn ignition on. Connect voltmeter between EGR controller connector terminal No. 1 and ground. If battery voltage is present, go to next step. If battery voltage is not present, check wiring between EGR controller connector terminal No. 1 and main relay connector terminal No. 3 for an open circuit.

8) Turn ignition off. Disconnect EGR controller connector. Disconnect ECM connector. Connect breakout box to ECM connector. Reconnect ECM. Connect ohmmeter between breakout box pin No. 40 and EGR controller connector terminal No. 2. If ohmmeter reads zero ohms, go to next step. If ohmmeter does not read zero ohms, check wiring between EGR controller connection terminal No. 2 and breakout box pin No. 40 for an open circuit.

9) Turn ignition on. Disconnect EGR connector. Connect voltmeter between breakout box pins No. 40 and 42. If voltmeter reads less than one volt, go to next step. If voltmeter does not read less than one volt, check wiring between EGR controller connector terminal No. 2 and breakout box pin No. 40 for a short circuit to voltage.

10) Turn ignition off. Ensure EGR connector is connected. Turn ignition on. Use Volvo Scan Tool (998-8686) to check if EGR controller functions. If EGR controller functions, code was caused by poor contact in control module and/or EGR controller connector. Repair as necessary. If EGR controller does not function, retest using new EGR controller.

11) If fault is intermittent, check EGR controller connection and ECM connectors for signs of loose connection and contact



resistance. Check wiring between EGR controller connector terminal No. 2 and ECM connector terminal No. 40 for an intermittent open circuit. Also check wiring between EGR controller connector terminal No. 1 and main relay connector terminal No. 3 for an intermittent open circuit.

#### Code 3-1-1 (Vehicle Speed Sensor Signal)

1) Test drive vehicle. Using Volvo Scan Tool (998-8686), read off VSS signal. If speed is zero MPH, fault is permanent. Go to next step. If speed is okay, fault is intermittent. Go to step 6).

2) Test drive vehicle and ensure speedometer functions. If speedometer shows zero MPH, speedometer or one of its components is defective. If speedometer is okay, determine if speedometer is VDO or Yazaki style. See the INSTRUMENT PANELS article in the ACCESSORIES/SAFETY EQUIPMENT section. If speedometer is VDO, go to next step. If speedometer is Yazaki, go to step 4).

3) Turn ignition on. Check if Code 1-3-1 is stored. If Code 1-3-1 is stored, check wiring between instrument cluster connector terminal A7 and ECM terminal B18 for a short circuit to voltage. If Code 1-3-1 is not stored, go to next step.

4) Connect breakout box between ECM and ECM connector. Shift transmission to Neutral. Raise and support front of vehicle. Turn ignition on. Connect voltmeter between breakout box pins No. 18 and 28. Rotate front wheels. If voltmeter reading varies between .5-5 volts, source of code is poor contact in ECM connector. Repair as necessary. If voltmeter shows a steady reading of about zero volts, check wiring between instrument cluster connector terminal A7 and ECM terminal B18 for a short circuit to ground. If voltmeter shows a steady reading of greater than 5 volts, on VDO speedometer, check wiring between instrument cluster connector terminal A7 and ECM terminal B18 for an open circuit. On Yazaki speedometer, go to next step.

5) Turn ignition off. Connect an ohmmeter between breakout box pins No. 18 and 28. If ohmmeter reads about 500 ohms, check wiring between instrument cluster connector terminal A7 and control module terminal B18 for a short circuit to voltage. If ohmmeter does not read 500 ohms, check wiring between instrument cluster connector terminal A7 and control module terminal B18 for an open circuit.

6) Turn ignition on. Check if Code 1-3-1 is stored. If Code 1-3-1 is stored, check wiring between instrument cluster connector terminal A7 and ECM terminal B18 for an intermittent short circuit to voltage. If Code 1-3-1 is not stored, check instrument cluster circuit for intermittent faults. Check ECM and instrument cluster connectors for an open circuit. Also check wiring between instrument cluster connector terminal A7 and ECM terminal B18 for an intermittent open circuit or intermittent short to ground.

#### Code 3-1-4 (Camshaft Position Sensor Signal)

1) Check for other codes. If no other codes are present, go to next step. If Codes 1-2-3, 4-1-1, and possibly 4-1-3 are stored, check TP sensor, ECT sensor, camshaft position sensor, and EGR temperature sensor connection at ECM connector terminal A18 for signs of contact resistance and oxidation.

2) Using Volvo Scan Tool (998-8686) check status message to determine whether fault is permanent or intermittent. If fault is permanent, go to next step. If fault is intermittent, go to step 12).

3) Turn ignition off. Wait about 2 minutes. Disconnect camshaft position sensor. Connect an ohmmeter between camshaft position sensor connector terminal No. 1 and ground. If ohmmeter reads about zero ohms, go to step 5). If ohmmeter does not read about zero ohms, go to next step.

4) Turn ignition off. Disconnect ECM connector. Disconnect camshaft position sensor connector. Ensure ECM connector terminals are clean and free of oxidation. Reconnect ECM connector. Connect an

ohmmeter between camshaft position sensor terminal No. 1 and ground. If ohmmeter reads about zero ohms, source of code is poor contact in ECM connector. If ohmmeter does not read about zero ohms, check wiring between camshaft position sensor connector terminal No. 1 and ECM connector A18 for an open circuit.

5) Turn ignition on. Disconnect camshaft position sensor connector. Connect voltmeter between camshaft position sensor connector terminal No. 3 and ground. If battery voltage is present, go to step 7). If battery voltage is not present, go to next step.

6) Turn ignition off. Disconnect camshaft position sensor. Ensure ECM connector terminals are clean and free of oxidation. Reconnect ECM. Turn ignition on. Connect voltmeter between camshaft position sensor connector terminal No. 3 and ground. If voltmeter shows battery voltage, source of DTC is poor contact in ECM connector. If voltmeter does not show battery voltage, check wiring between CMP sensor connector terminal No. 3 and ECM terminal A36 for an open circuit.

7) Turn ignition on. Disconnect camshaft position sensor connector. Connect voltmeter between camshaft position sensor connector terminal No. 2 and ground. If voltmeter reads about 5 volts, go to step 10). If voltmeter reads more than about 5 volts, check wiring between camshaft position sensor connector terminal No. 2 and ECM terminal A21 for a short circuit to voltage, then go to step 11). If voltmeter reads less than about 5 volts, go to next step.

8) Turn ignition off. Wait about 2 minutes. Disconnect camshaft position sensor. Connect an ohmmeter between camshaft position sensor connector terminal No. 2 and ground. If ohmmeter reads infinite resistance, go to next step. If ohmmeter reads about zero ohms, check wiring between camshaft position sensor connector terminal No. 2 and ECM connector terminal A21 for a short circuit to ground.

9) Turn ignition off. Disconnect camshaft position sensor. Disconnect ECM connector. Ensure ECM connector terminals are clean and free of oxidation. Reconnect ECM. Connect an ohmmeter between camshaft position sensor connector terminal No. 2 and ground. If ohmmeter reads .5-3 k/ohms, check for poor contact at ECM connector. If ohmmeter does not read .5-3 k/ohms, check wiring between camshaft position sensor connector terminal No. 2 and ECM connector terminal A21 for an open circuit.

10) Reconnect camshaft position sensor. Attempt to start engine. If engine starts, code is caused by poor contact at camshaft position sensor connector or ECM connector. If engine starts, retest using new camshaft position sensor.

11) Ensure camshaft position sensor is connected. If engine starts, camshaft position sensor is okay. If engine does not start, retest using new camshaft position sensor.

12) If fault is intermittent, check camshaft position sensor and ECM connectors for loose connection, contact resistance, or oxidation. Check wiring between camshaft position sensor connector terminal No. 1 and ECM terminal A18 for an intermittent open circuit. Check wiring between camshaft position sensor connector terminal No. 2 and ECM terminal A21 for an intermittent open circuit, short circuit to ground, or short circuit to voltage. Also check wiring between camshaft position sensor connector terminal No. 3 and ECM terminal A36 for an intermittent open circuit.

#### Code 3-1-5 (EVAP System)

1) Check for other codes. If Code 5-4-1 is also present, check that code first. If Code 5-4-1 is not present, go to next step.

2) Start and run engine at idle. Remove vacuum hose between EVAP valve and intake manifold. If vacuum is present in hose, go to next step. If vacuum is not present in hose, check for obstruction. Also check hose connection to intake manifold.

3) Start and run engine at idle. Connect hose between EVAP

valve and intake manifold to EVAP valve. Remove hose between EVAP valve and canister from EVAP valve. If there is no vacuum in EVAP valve when valve is not activated, go to next step. If there is vacuum, retest using new EVAP valve.

4) Start and run engine at idle. Disconnect hose between EVAP valve and canister at EVAP valve. Check if there is vacuum in EVAP valve when valve is activated. If there is vacuum, go to next step. If there is no vacuum, retest using new EVAP valve.

5) Start and run engine at idle. Connect vacuum hose between EVAP valve and canister to EVAP valve. Remove vacuum hose between EVAP valve and canister from canister. Check if there is vacuum in hose when EVAP valve is activated. If there is vacuum, check if all canister inlets and outlets are okay. Repair as necessary. If inlets and outlets are okay, fault is intermittent. Go to next step. If no vacuum is present, check for obstruction in hose between EVAP valve and canister.

6) Check hose between EVAP valve and intake manifold, and between EVAP valve and canister for an obstruction. Check canister connections to ensure they are not clogged. Check EVAP valve for dirt or deposits. Repair as necessary. If no faults can be found, test system using new EVAP valve.

#### Code 3-2-5 (Memory Failure)

Check wiring between ECM terminal A26 and battery positive terminal for an intermittent open circuit. Also check ECM connector and battery positive terminal for a loose connection, contact resistance, or oxidation.

#### Code 3-3-5 (Fault In Wiring Between TCM and ECM)

1) Check status message on Volvo Scan Tool (998-8686). If status message is PERMANENT FAULT, SIGNAL TOO HIGH or PERMANENT FAULT, SIGNAL TOO LOW, go to next step. If status message is INTERMITTENT FAULT, SIGNAL TOO HIGH or INTERMITTENT FAULT, SIGNAL TOO LOW, go to step 3).

2) If fault is permanent and signal is too high, check wiring between ECM terminal B26 and Transmission Control Module (TCM) terminal B15 for a short circuit to voltage. If fault is permanent and signal is too low, check wiring between ECM terminal B26 and TCM terminal B15 for a short circuit to ground.

3) If fault is intermittent and signal is too high, check wiring between ECM terminal B26 and TCM terminal B15 for an intermittent short circuit to voltage. If fault is intermittent and signal is too low, check wiring between ECM terminal B26 and TCM terminal B15 for an intermittent short circuit to ground.

#### Code 4-1-1 (Throttle Position Sensor Signal)

1) Check for other codes. If no other codes are stored, go to next step. If Codes 1-2-3, 1-1-2, 3-1-4 and possibly 4-1-3 are stored, check Throttle Position (TP) sensor, ECT sensor, CMP sensor, and EGR temperature sensor connector on ECM for contact resistance and oxidation.

2) Check status message on Volvo Scan Tool (998-8686). If status message is PERMANENT FAULT, SIGNAL TOO HIGH, go to step 3). If status message is PERMANENT FAULT, SIGNAL TOO LOW, go to step 10). If status message is INTERMITTENT FAULT, SIGNAL TOO HIGH, go to step 14). If status message is INTERMITTENT FAULT, SIGNAL TOO LOW, go to step 16).

3) Turn ignition off. Wait about 2 minutes. If engine cooling fan is running, wait for it to switch off. Disconnect TP sensor. Connect ohmmeter between TP sensor connector terminal No. 1 and ground. If ohmmeter reads about zero ohms, go to step 5). If ohmmeter does not read about zero ohms, go to next step.

4) Turn ignition off. Disconnect TP sensor. Disconnect ECM.

Clean ECM connector of oxidation or other contact resistance. Reconnect ECM. Connect an ohmmeter between TP sensor connector terminal No. 1 and ground. If ohmmeter reads about zero ohms, code is caused by poor contact at ECM connector. If ohmmeter does not read about zero ohms, check wiring between TP sensor connector terminal No. 1 and ECM terminal A18 for an open circuit.

5) Turn ignition on. Disconnect TP sensor. Connect voltmeter between TP sensor connector terminal No. 2 and ground. If voltmeter reads about 5 volts, go to next step. If voltmeter does not show about 5 volts, check wiring between TP sensor connector terminal No. 2 and ECM terminal A15 for a short circuit to voltage.

6) Turn ignition on. Disconnect TP sensor. Connect voltmeter between TP sensor connector terminal No. 3 and ground. If voltmeter reads about 5 volts, go to step 8). If voltmeter reads about zero volts, go to step 7). If voltmeter reads more than about 5 volts, check wiring between TP sensor connector terminal No. 3 and ECM terminal A16 for a short circuit to voltage. If wiring is okay, go to step 9).

7) Turn ignition off. Disconnect TP sensor. Disconnect ECM connector. Ensure ECM connector terminals are clean and tight. Reconnect ECM. Turn ignition on. Connect voltmeter between TP sensor connector terminal No. 3 and ground. If voltmeter reads about 5 volts, code was caused by poor contact at ECM connector. If voltmeter does not read about 5 volts, check wiring between TP sensor connector terminal No. 3 and ECM terminal A16 for an open circuit.

8) Turn ignition off. Reconnect TP sensor. Start and run engine at idle. Using Volvo Scan Tool (998-8686), read off throttle angle. Throttle angle should be 3-8 degrees when engine is at idle, increasing as accelerator is depressed. If reading is okay, source of code is poor contact at TP sensor connector. If reading is not okay, retest using new TP sensor.

9) Turn ignition off. Connect TP sensor. Start and run engine at idle. Using Volvo Scan Tool (998-8686), read off throttle angle. Throttle angle should be 3-8 degrees when engine is at idle, increasing as accelerator is depressed. If reading is okay, TP sensor is okay. If reading is not okay, retest using new TP sensor.

10) If fault is permanent and signal is too low, turn ignition off. Wait about 2 minutes. Disconnect TP sensor. Connect ohmmeter between TP sensor connector terminal No. 2 and ground. If ohmmeter reads .4-.6 k/ohms, go to step 12). If ohmmeter reads about zero ohms, check wiring between TP sensor connector terminal No. 2 and ECM terminal A15 for a short circuit to ground. If ohmmeter reads infinite resistance, go to next step.

11) Turn ignition off. Disconnect TP sensor. Disconnect ECM connector. Ensure ECM connector terminals are clean and tight. Reconnect ECM connector. Turn ignition on. Connect voltmeter between TP sensor connector No. 2 and ground. If voltmeter reads about 5 volts, code is caused by poor contact at ECM terminals. If voltmeter does not read about 5 volts, check wiring between TP sensor connector terminal No. 2 and ECM connector terminal A15 for an open circuit.

12) Turn ignition on. Disconnect TP sensor connector. Connect voltmeter between TP sensor connector terminal No. 3 and ground. If voltmeter reads about 5 volts, go to next step. If voltmeter does not read about 5 volts, check wiring between TP sensor connector terminal No. 3 and ECM terminal A16 for a short circuit to ground.

13) Turn ignition off. Connect TP sensor. Start engine. Using Volvo Scan Tool (998-8686), read off throttle angle. Throttle angle should be 3-8 degrees at idle, and increase as accelerator pedal is depressed. If reading is okay, source of code is poor contact in TP sensor connector. If reading is not okay, retest using new TP sensor.

14) If fault is intermittent and signal is too high, turn ignition off. Disconnect TP sensor. Turn ignition on. Connect voltmeter between TP sensor connector terminal No. 2 and ground. If

voltmeter reads about 5 volts, go to next step. If voltmeter does not read about 5 volts, check wiring between TP sensor connector terminal No. 2 and ECM terminal A15 for a short circuit to voltage.

15) Check TP sensor and ECM sensor connector terminals for loose connection, contact resistance, or oxidation. Check wiring between TP sensor connector terminal No. 3 and ECM terminal A16 for an intermittent open circuit or short circuit to voltage.

16) If fault is intermittent and signal is too low, check TP sensor and ECM sensor connector terminals for loose connection, contact resistance, and oxidation. Check wiring between TP sensor connector terminal No. 3 and ECM connector terminal A16 for an intermittent short circuit to ground. Also check wiring between TP sensor connector terminal No. 2 and ECM connector terminal A15 for an intermittent open circuit or short circuit to ground.

#### Code 4-1-3 (EGR Temperature Sensor Signal)

1) Check for any other codes. If Code 1-5-4 is present, perform testing for that code first. If no other codes are present, go to next step.

2) Using Volvo Scan Tool (998-8686), check code status message. If SIGNAL TOO HIGH is displayed, go to next step. If SIGNAL TOO LOW is displayed, go to step 13). If FAULTY SIGNAL is displayed, go to step 16).

3) If SIGNAL TOO HIGH is displayed, turn ignition on. Using Volvo Scan Tool, use Diagnostic Test Mode (DTM) No. 3 to check if EGR controller functions. If EGR controller functions, go to next step. If EGR controller does not function, go to step 7).

4) Turn ignition off. Disconnect wire from EGR controller connector terminal No. 2. Connect jumper wire to free end of disconnected wire. Start and run engine at idle. Connect other end of jumper wire to ground. If engine runs unevenly at idle, go to next step. If engine does not run unevenly, check vacuum in EGR controller. See CODE 2-4-1 (EGR SYSTEM FLOW MALFUNCTION).

5) Run engine at idle. Connect free wire at EGR temperature sensor to ground. Using Volvo Scan Tool (998-8686), observe voltage at EGR temperature sensor. If voltage drops when engine runs unevenly, go to step 17). If voltage does not drop when engine runs unevenly, go to next step.

6) Turn ignition off. Disconnect EGR temperature sensor. Turn ignition on. Connect voltmeter between EGR temperature sensor connector terminal No. 2 and ground. If voltmeter reads zero volts, go to next step. Repair as necessary. If voltmeter does not read zero volts, check wire between EGR temperature sensor connector terminal No. 2 and ECM terminal A18 for a short to voltage.

7) Turn ignition off. Wait about 2 minutes. Disconnect EGR temperature sensor. Connect an ohmmeter between EGR temperature sensor connector terminal No. 2 and ground. If ohmmeter reads about zero ohms, go to step 9). If ohmmeter does not read about zero ohms, go to next step.

8) Turn ignition off. Disconnect EGR temperature sensor connector. Ensure connector terminals are clean and tight. Repair as necessary. Reconnect EGR temperature sensor connector. Connect an ohmmeter between EGR temperature sensor connector terminal No. 2 and ground. If ohmmeter reads about zero ohms, code is caused by poor contact in ECM connector. If ohmmeter does not read about zero ohms, check wiring between EGR temperature sensor connector terminal No. 2 and ECM terminal A18 for an open circuit.

9) Turn ignition on. Disconnect EGR temperature sensor connector. Connect voltmeter between EGR temperature sensor connector terminal No. 1 and ground. If voltmeter reads about 5 volts, go to step 11). If voltmeter reads less than 5 volts, go to next step. If voltmeter reads greater than 5 volts, check wiring between EGR temperature sensor connector terminal No. 1 and ECM terminal A35 for a

short circuit to voltage, then go to step 12).

10) Turn ignition off. Disconnect EGR temperature sensor. Ensure connector terminals are clean and tight. Repair as necessary. Reconnect connector. Turn ignition on. Connect voltmeter between EGR temperature sensor connector terminal No. 1 and ground. If voltmeter reads about 5 volts, code was caused by poor contact in ECM connector. If voltmeter does not read about 5 volts, check wiring between EGR temperature sensor connector terminal No. 1 and ECM terminal A35 for an open circuit.

11) Turn ignition off. Disconnect EGR temperature sensor connector. Connect an ohmmeter between EGR connector terminals No. 1 and 2. If ohmmeter reads about 200 k/ohms, cause of code was poor contact in EGR temperature sensor connector. Repair as necessary. If about 200 k/ohms are not present, retest using new EGR temperature sensor.

12) EGR temperature sensor may give defective reading due to signal wiring shorting to voltage. To check, turn ignition off. Disconnect EGR temperature sensor. Connect an ohmmeter between EGR temperature sensor connector terminals No. 1 and 2. If ohmmeter reads about 200 k/ohms, EGR temperature sensor is okay. If ohmmeter does not read about 200 k/ohms, retest using new EGR temperature sensor.

13) If signal is too low, start engine and run at idle. Using Volvo Scan Tool (998-8686), check voltage at EGR temperature sensor. If voltage is greater than .1 volt, go to step 18). If voltage is not greater than .1 volt, go to next step.

14) Turn ignition off. Disconnect EGR temperature sensor connector. Start engine and run at idle. Using Volvo Scan Tool (998-8686), read off EGR temperature sensor signal. If reading is about 5 volts, go to next step. If reading is not about 5 volts, check wiring between EGR temperature sensor connector terminal No. 1 and ECM terminal A35 for a short circuit to ground.

15) Turn ignition off. Disconnect EGR temperature sensor connector. Connect an ohmmeter between EGR temperature sensor connector terminals No. 1 and 2. If ohmmeter reads about 200 k/ohms, cause of code is poor contact in EGR temperature sensor connector. Repair as necessary. If ohmmeter does not read about 200 k/ohms, retest using new EGR temperature sensor.

16) Check EGR temperature sensor and ECM connector terminals for signs of loose connection or poor contact. Repair as necessary. Check wiring between EGR temperature sensor connector terminal No. 1 and ECM terminal A35 for an intermittent open circuit, short circuit to ground, or short circuit to voltage. Also check wiring between EGR temperature connector terminal No. 2 and ECM terminal A18 for an intermittent open circuit. Repair as necessary.

17) If fault is intermittent and signal is too high, check EGR temperature sensor connector for signs of loose connection or poor contact. Repair as necessary. Check wiring between EGR temperature sensor connector terminal No. 1 and ECM terminal A35 for an intermittent open circuit or short circuit to voltage. Also check wiring between EGR temperature sensor connector terminal No. 2 and ECM terminal A18 for an intermittent open circuit.

18) If fault is intermittent and signal is too low, check wiring between EGR temperature sensor connector terminal No. 1 and ECM terminal A35 for an intermittent short circuit to ground.

#### Code 4-1-4 (Charge Pressure Control)

1) Turn ignition on. Leave MAF sensor connected. Connect voltmeter between MAF sensor connector terminals No. 2 and 4. If voltmeter reads .1-.2 volt, go to step 3). If voltmeter does not read .1-.2 volt, go to next step.

2) Turn ignition off. Ensure MAF sensor and ECM connector terminals are clean and tight. Repair as necessary. Reconnect connectors. Turn ignition on. Connect voltmeter between MAF sensor

connector terminals No. 2 and 4. If voltmeter reads .1-.2 volt, source of code was poor contact in MAF or ECM connector terminals. If voltmeter does not read .1-.2 volt, retest using new MAF sensor.

3) Turn ignition off. Connect breakout box and check grounds. See COMPUTERIZED ENGINE CONTROLS in I - SYSTEM/COMPONENT TESTS article. Disconnect ECM. Turn ignition on. Connect voltmeter between breakout box pin No. 42 and ground. If battery voltage is present, go to next step. If battery voltage is not present, check wiring between ECM terminal B42 and Transmission Control Module (TCM) terminal B1 for an intermittent fault.

4) Turn ignition off. Check Turbocharger (TC) control valve and ECM connector for contact resistance or poor contact. Repair as necessary. Reconnect TC control valve and ECM connectors. Turn ignition on. Using Volvo scan tool in Diagnostic Test Mode (DTM) No. 3, check that TC control valve ticks. If TC control valve ticks, go to next step. If TC control valve does not tick, retest using new TC control valve.

5) Turn ignition off. Check hoses between TC and TC control valve, and hose between TC control valve and pressure servo for wastegate valve for obstruction or kinks. Also check that TC control valve is not blocked between Red and Yellow connectors when valve is activated. Valve should be open between Red and Yellow connectors when not activated. If hoses and TC control valve are okay, go to next step. If hoses and/or TC control valve are blocked, repair as necessary.

6) Turn ignition off. Remove hose from pressure servo. Connect Manometer (999-5230) and Pressure Tester (998-5496) to pressure servo. Pump up pressure to about 46.6 psi. If pressure servo fully opens, check pressure servo setting. See procedures in the I - SYSTEM/COMPONENT TESTS article. Replace wastegate valve pressure servo. If pressure servo is not okay, retest with a new pressure servo. Replace wastegate valve pressure servo.

Code 4-1-6 (Charge Pressure Reduction From Transmission Control Module)

1) Using Volvo Scan Tool (998-8686), check status message. If fault is permanent, go to next step. If fault is intermittent, go to step 3).

2) If fault is permanent, check wiring between ECM terminal B42 and Transmission Control Module (TCM) terminal B1 for a short circuit to ground. Repair as necessary.

3) If fault is intermittent, check wiring between ECM terminal B42 and Transmission Control Module (TCM) terminal B1 for an intermittent short circuit to ground. Repair as necessary.

Code 4-2-5 (Rear HO2S Lambdasond)

1) Perform a compression check on all cylinders. Repair as necessary. If compression is okay, go to next step.

2) Check for air leakage in intake system. Repair as necessary. If there is no air leakage in intake system, check for air leakage in exhaust system. Repair as necessary. If there is no air leakage in exhaust system, check fuel and residual pressure. Repair as necessary. If fuel and residual pressure are okay, retest using new HO2S.

Code 4-3-2 (Temperature Warning Level 1) Or

Code 5-1-3 (Temperature Warning Level 2)

1) Check for other codes. If Code 5-1-4 is stored, perform testing for that code first. If Code 5-1-4 is not stored, go to next step.

2) Using Volvo Scan Tool (998-8686), use Diagnostic Test Mode (DTM) 3 to check if engine cooling fan is functioning and that air is being drawn into connector for ECM box air hose in fan shroud. If

engine cooling fan operates, go to next step. If engine cooling fan does not operate, perform testing for Code 5-1-4.

3) Turn ignition on. Set blower switch at highest speed. Close dash vents. Check if there is a slight stream of air from control module box air hose. If air is blowing from hose, control module box is cooling okay. Erase code. If no air is coming from hose, ensure hoses and couplings are in place and not blocked. Repair as necessary.

#### Code 4-3-5 (Front HO2S Too Slow)

1) Check for other codes. If Code 4-3-6 is stored, perform testing for that code first. If Code 4-3-6 is not stored, go to next step.

2) Perform a compression check on all cylinders. Repair as necessary. If compression is okay, go to next step.

3) Check for air leakage in intake system. Repair as necessary. If there is no air leakage in intake system, check for air leakage in exhaust system. Repair as necessary. If there is no air leakage in exhaust system, check fuel and residual pressure. Repair as necessary. If fuel and residual pressure are okay, retest using new front HO2S.

#### Code 4-3-6 (Rear HO2S Compensation)

1) Check for other codes. If Code 4-2-5 is stored, perform testing for that code first. If Code 4-2-5 is not stored, go to next step.

2) Perform a compression check on all cylinders. Repair as necessary. If compression is okay, go to next step.

3) Check for air leakage in intake system. Repair as necessary. If there is no air leakage in intake system, check for air leakage in exhaust system. Repair as necessary. If there is no air leakage in exhaust system, check fuel and residual pressure. Repair as necessary. If fuel and residual pressure are okay, go to next step.

4) Turn ignition on. Connect fuel pressure gauge to system. Squeeze hose between EVAP valve and intake manifold with Hose Pliers (115 8957). Code for EVAP system can be set. Start engine and run at idle until rear HO2S starts operating. Rear HO2S starts operating a short time after rear HO2S preheating starts.

5) Increase fuel pressure by squeezing hose after fuel pressure regulator with Hose Pliers (115 8957). Voltage across rear HO2S terminals should increase to about .8 volt. Remove hose pliers. Remove instrument cluster hose at intake manifold. If voltage across rear HO2S terminals drops to about zero volts, retest using new front HO2S. If voltage across rear HO2S terminals does not drop to about zero volts, retest using new rear HO2S.

#### Code 4-4-3 (TWC Efficiency)

1) Check for other codes. If any code for misfiring is stored (Codes 4-5-1, 4-5-2, 4-5-3, 4-5-4, 4-5-5, 5-4-2, 5-4-3, 5-5-1, 5-5-2, 5-5-3, 5-5-4, 5-5-5, 5-4-4 or 5-4-5) perform that testing first. If Codes 4-3-5 or 4-3-6 are stored, perform testing for that code first. If none of the above codes are stored, go to next step.

2) Perform a compression check on all cylinders. Repair as necessary. If compression is okay, go to next step.

3) Check for air leakage in intake system. Repair as necessary. If there is no air leakage in intake system, check for air leakage in exhaust system. Repair as necessary. If there is no air leakage in exhaust system, check fuel and residual pressure. Repair as necessary. If fuel and residual pressure are okay, retest using new TWC.

#### Code 4-4-4 (Acceleration Sensor Signal)

1) Check status message on Volvo Scan Tool (998-8686). If



status message reads PERMANENT FAULT, SIGNAL TOO HIGH, go to next step. If status message reads PERMANENT FAULT, SIGNAL TOO LOW, go to step 12). If status message reads INTERMITTENT FAULT, SIGNAL TOO HIGH, go to step 13). If status message reads INTERMITTENT FAULT, SIGNAL TOO LOW, go to step 15).

2) If PERMANENT FAULT, SIGNAL TOO HIGH is displayed on scan tool, turn ignition off. Wait about 2 minutes. Disconnect acceleration sensor. Connect an ohmmeter between acceleration sensor connector terminal No. 1 and ground. If ohmmeter reads about 5-20 k/ohms, go to step 7). If ohmmeter reads infinite resistance, go to next step. If ohmmeter reads about zero ohms on non-A/C equipped vehicles, go to step 4). If ohmmeter reads about zero ohms on A/C equipped vehicles, go to step 5).

3) Turn ignition off. Disconnect acceleration sensor connector. Ensure connector terminals are clean and tight. Repair as necessary. Reconnect connector. Connect an ohmmeter between acceleration sensor connector terminal No. 1 and ground. If ohmmeter reads 5-20 k/ohms, code was caused by poor connector contact. If ohmmeter does not read 5-20 k/ohms, check wiring between acceleration sensor connector terminal No. 1 and ECM terminal B1 for an open circuit.

4) Turn ignition off. Disconnect acceleration sensor connector. Disconnect ECM. Connect an ohmmeter between acceleration sensor connector terminal No. 1 and ground. If ohmmeter reads about zero ohms, check wiring between acceleration sensor connector terminal No. 1 and ECM terminal B1 for a short circuit to ground. If ohmmeter reads infinite resistance, check prerouted wiring between A/C pressure sensor connector terminal No. 3 and ECM terminal B29 for a short circuit to ground.

5) Turn ignition off. Disconnect acceleration sensor connector. Disconnect A/C pressure sensor connector. Connect an ohmmeter between acceleration sensor connector terminal No. 1 and ground. If ohmmeter reads about zero ohms, go to next step. If ohmmeter reads 5-20 k/ohms, retest using new A/C pressure sensor.

6) Turn ignition off. Disconnect acceleration sensor connector. Connect A/C pressure sensor. Disconnect ECM. Connect ohmmeter between acceleration sensor connector terminal No. 1 and ground. If ohmmeter still reads zero ohms, check wiring between acceleration sensor connector terminal No. 1 and ECM terminal B1 for a short to ground. If ohmmeter reads infinite resistance, check wiring between A/C pressure sensor connector terminal No. 3 and ECM terminal B29 for a short circuit to ground.

7) Turn ignition off. Disconnect acceleration sensor connector. Connect an ohmmeter between acceleration sensor connector terminal No. 2 and ground. If ohmmeter reads about zero ohms, go to step 9). If ohmmeter does not read about zero ohms, go to next step.

8) Turn ignition off. Disconnect acceleration sensor connector. Ensure connector terminals are clean and tight. Repair as necessary. Reconnect connector. Connect an ohmmeter between acceleration sensor connector terminal No. 2 and ground. If ohmmeter reads about zero ohms, go to next step. If ohmmeter does not read about zero ohms, check wiring between acceleration sensor connector terminal No. 2 and ECM terminal B28 for an open circuit.

9) Turn ignition on. Disconnect acceleration sensor connector. Connect voltmeter between acceleration sensor connector terminal No. 3 and ground. If voltmeter reads about 5 volts, go to step 11). If voltmeter reads more than 5 volts, check wiring between acceleration sensor connector terminal No. 3 and ECM terminal B32 for a short to voltage. If voltmeter reads about zero volts, go to next step.

10) Turn ignition off. Disconnect acceleration sensor connector. Ensure connector terminals are clean and tight. Reconnect connector. Turn ignition on. Connect voltmeter between acceleration

sensor connector terminal No. 3 and ground. If voltmeter reads about 5 volts, code was caused by poor terminal contact. If voltmeter does not read about 5 volts, check wiring between acceleration sensor connector terminal No. 3 and ECM terminal B32 for an open circuit.

11) Turn ignition on. Reconnect acceleration sensor connector. Erase code. Start engine and run at idle. If code does not reoccur, source of code is poor contact in acceleration sensor connector. Repair as necessary. If code reoccurs, retest using new acceleration sensor.

12) If fault is permanent and signal is too low, turn ignition off. Disconnect acceleration sensor. Turn ignition on. Connect voltmeter between acceleration sensor connector terminal No. 3 and ground. If voltmeter reads about 5 volts, retest using new acceleration sensor. If voltmeter does not read about 5 volts, check wiring between acceleration sensor connector terminal No. 3 and ECM terminal B32 for a short circuit to ground.

13) If fault is intermittent and signal is too high, check acceleration sensor and ECM connectors for poor terminal contact. Repair as necessary. Check wiring between acceleration sensor connector terminal No. 1 and ECM terminal B1 for an intermittent open or short circuit to ground. Check wiring between acceleration sensor connector terminal No. 2 and ECM terminal B28 for an intermittent open circuit. Check wiring between acceleration sensor connector terminal No. 3 and ECM terminal B32 for an intermittent short circuit to voltage or intermittent open circuit.

14) On vehicles with A/C, also check wiring between A/C pressure sensor connector terminal No. 3 and ECM terminal B29 for an intermittent short circuit to ground. On vehicles without A/C, check prerouted wiring between connector No. 3 for A/C pressure sensor and ECM terminal B29 for an intermittent short circuit to ground.

15) If fault is intermittent and signal is too low, check wiring between acceleration sensor connector terminal No. 3 and ECM terminal B32 for an intermittent short circuit to ground.

Code 4-5-1 (Misfire Cylinder No. 1),  
Code 4-5-2 (Misfire Cylinder No. 2),  
Code 4-5-3 (Misfire Cylinder No. 3),  
Code 4-5-4 (Misfire Cylinder No. 4),  
Code 4-5-5 (Misfire Cylinder No. 5),  
Code 5-4-2 (Misfire More Than One Cylinder),  
Code 5-4-3 (Misfire At Least One Cylinder),  
Code 5-5-1 (Misfire Cylinder No. 1, TWD Damage),  
Code 5-5-2 (Misfire Cylinder No. 2, TWC Damage),  
Code 5-5-3 (Misfire Cylinder No. 3, TWC Damage),  
Code 5-5-4 (Misfire Cylinder No. 4, TWC Damage),  
Code 5-5-5 (Misfire Cylinder No. 5, TWC Damage),  
Code 5-4-4 (Misfire More Than One Cylinder, TWC Damage), Or  
Code 5-4-5 (Misfire At Least One Cylinder, TWC Damage)

1) Check for other trouble codes. If any other trouble codes are stored, perform diagnosis for other codes first. If no other codes are stored, go to next step.

2) Read off all other misfiring codes. If Code 5-4-2 and/or Code 5-4-4 are stored, misfiring has occurred in more than one cylinder. If misfiring occurred in several cylinders, go to step 6). If misfiring occurred in one cylinder, go to next step.

3) Check all spark plugs, cylinder compression, cooling system, ignition wiring, and distributor cap and rotor. Repair as necessary. If all components are okay, use Volvo Scan Tool (998-8686) and check flywheel. Start engine and run at idle. Read off values on scan tool for FLY ADAP B, FLY ADAP C, FLY ADAP D, and FLY ADAP E. If readings are -97 to +97, check wiring and injector connectors. If any readings are incorrect, check RPM sensor tip and hole down by flywheel/connecting flange for damage, scratches, and metal particles.

If RPM sensor and hole are okay, retest using new flywheel.

4) Check wiring between relevant injector and ECM for signs of an intermittent open circuit, short circuit to ground, or intermittent short circuit to voltage. Also check suspect injector connector and ECM connector for poor terminal contact or oxidation. Repair as necessary, then go to next step.

5) Check for air leakage in intake or exhaust system. Repair as necessary. If no air leakage is present, check fuel and residual pressure. Repair as necessary. If fuel and residual pressure are okay, system is operating normally.

6) If misfiring is occurring in several cylinders, remove spark plugs and perform a compression test. Repair as necessary. If compression is okay, go to next step.

7) Connect Pressure Tester (998 5496) to expansion tank. Pump up pressure to about 14.5 psi. Shine flashlight into each cylinder and ensure there is no leakage between cooling system and cylinders. If leakage is present, repair as necessary. If no leakage is present, go to next step.

8) Remove all ignition wires. Check wires for cracks or arcing. Measure resistance in each ignition wire. Depending on length, resistance should be 1.5-4.5 k/ohms. Replace ignition wires as necessary. If wires are okay, go to next step.

9) Remove distributor cap and rotor. Check distributor cap and rotor for cracks, arcing, or other signs of damage. Replace as necessary. If cap and rotor are okay, go to next step.

10) Turn ignition off. Disconnect cable terminal from ignition coil connector terminal No. 15. Connect an ohmmeter between ignition coil terminals No. 1 and 15. If ohmmeter reads .5-1.5 ohms, go to next step. If ohmmeter does not read .5-1.5 ohms, retest using new ignition coil, then go to step 12).

11) Turn ignition off. Disconnect ignition coil high tension wire. Connect an ohmmeter between ignition coil terminal No. 15 and high tension connector on ignition coil. If ohmmeter reads 8-9 k/ohms, go to next step. If ohmmeter does not read 8-9 k/ohms, retest using new ignition coil. Go to next step.

12) Install new spark plugs. Install distributor cap and connect all ignition wiring. Connect cable terminal to ignition coil. Start engine and run at idle. Connect voltmeter between ignition coil connector terminal No. 15 and ground. If voltmeter reads battery voltage, go to next step. If voltmeter does not read battery voltage, check voltage supply connectors at junction box.

13) Turn ignition off. Wait about 2 minutes. Disconnect power stage 4-pin connector. Connect ohmmeter between power stage connector terminal No. 1 and ground. If ohmmeter reads about zero ohms, go to next step. If ohmmeter does not read about zero ohms, check power stage ground connector for poor terminal contact. Repair as necessary, then go to next step.

14) Check wiring between power stage connector terminal No. 4 and ECM terminal B11, wiring between power stage connector terminal No. 1 and ground, and wiring between power stage connector terminal No. 3 and battery voltage for an intermittent open circuit, short circuit to ground, or short circuit to voltage. Ensure all connectors are clean and tight. Repair as necessary, then go to next step.

15) Start engine and run at idle. Using Volvo Scan Tool (998-8686), read off values on FLY ADAP B, FLY ADAP C, FLY ADAP D, and FLY ADAP E. If readings are -97 to +97, go to next step. If readings are not -97 to +97, check RPM sensor tip and hole down by flywheel/connecting flange for damage, scratches, and metal shavings. Repair as necessary. If RPM sensor and hole are okay, retest using new flywheel.

16) Check wiring between injectors connector terminal No. 1 and main relay terminal No. 3, and wiring between ECM terminal A41 and main relay connector terminal No. 1 for an intermittent open circuit.

Also check connectors at injectors, main relay, and ECM for loose connection. Repair as necessary. Go to next step.

17) Check wiring between ECM terminal B27 and fuel pump relay connector terminal No. 4, wiring between fuel pump relay connector terminal No. 2 and ground, wiring between battery positive terminal and fuel pump connector terminal No. 1, wiring between fuel pump relay connector terminal No. 3 and fuel pump connector terminal No. 1, and wiring between fuel pump connector terminal No. 2 and ground. Also check all connectors for good terminal contact. Repair as necessary. Go to next step.

18) Check intake and exhaust systems for air leakage. Check engine oil level. Check fuel and residual pressure. Repair as necessary. If all checks are okay, system is operating normally.

#### Code 5-1-4 (Engine Cooling Fan Half Speed)

1) Using Volvo Scan Tool (998-8686), read off status message. If PERMANENT FAULT, SIGNAL TOO HIGH is displayed, go to next step. If PERMANENT FAULT, SIGNAL TOO LOW is displayed, go to step 3). If INTERMITTENT FAULT, SIGNAL TOO HIGH is displayed, go to step 8). If INTERMITTENT FAULT, SIGNAL TOO LOW is displayed, go to step 9).

2) If PERMANENT FAULT, SIGNAL TOO HIGH is displayed, turn ignition off. Disconnect connector "B" from Fuel Control (FC) relay. Turn ignition on. Connect voltmeter between FC relay connector "B", terminal No. 1, and ground. If voltmeter reads about zero volts, retest using new FC relay. If voltmeter does not read about zero volts, check wiring between FC relay connector "B", terminal No. 1, and ECM terminal A7 for a short circuit to voltage.

3) If PERMANENT FAULT, SIGNAL TOO LOW is displayed, turn ignition off. Disconnect connector "A" from Fuel Control (FC) relay. Connect voltmeter between FC relay connector "A" and ground. If voltmeter reads battery voltage, go to next step. If voltmeter does not read battery voltage, check fusible link in wiring between starter motor and FC relay. Check relay and fan motor before replacing fusible link.

4) Turn ignition off. Disconnect connectors "A" and "B" from FC relay. Connect an ohmmeter between FC relay connector "B", terminal No. 1, and ground. If ohmmeter reads 28-38 k/ohms, go to step 6). If ohmmeter reads about zero ohms, check wiring between FC relay connector "B", terminal No. 1, and ECM terminal A7 for a short circuit to ground. If ohmmeter reads infinite resistance, go to next step.

5) Turn ignition off. Disconnect FC relay connectors "A" and "B". Ensure all terminal connectors are clean and tight. Reconnect connectors. Connect an ohmmeter between FC relay connector "B", terminal No. 1, and ground. If ohmmeter reads 28-38 k/ohms, go to step 7). If ohmmeter does not read 28-38 k/ohms, check wiring between FC relay connector "B", terminal No. 1, and ECM terminal A7 for an open circuit.

6) Turn ignition off. Disconnect connectors "A" and "B" from FC relay. Connect an ohmmeter between FC relay connector "B", terminal No. 2, and ground. If ohmmeter reads infinite resistance, go to next step. If ohmmeter does not read infinite resistance, check wiring between FC relay connector "B", terminal No. 2, and ECM terminal A22 for a short circuit to ground.

7) Turn ignition off. Ensure connectors "A" and "B" are connected to FC relay. Start engine and run at idle. Using Volvo Scan Tool (998-8686), read off status message. If status message is PERMANENT, SIGNAL TOO LOW, retest using new FC relay. If status message is intermittent, source of code is poor contact in FC relay and/or ECM connector. Ensure connector terminals are clean and free of oxidation.

8) If fault is intermittent and signal is too high, check wiring between FC relay connector "B", terminal No. 1, and ECM terminal A7 for an intermittent short circuit to voltage.

9) If fault is intermittent and signal is too low, check FC relay and ECM connectors for loose connection or poor terminal contact. Check wiring between FC relay connector "B", terminal No. 1, and ECM terminal A7 for signs of an intermittent open or short circuit to ground. Also check wiring between FC relay connector "A", terminal No. 1, and starter motor for an intermittent open circuit.

Code 5-2-1 (Front HO2S Preheating) Or

Code 5-2-2 (Rear HO2S Preheating)

1) Check status message using Volvo Scan Tool (998-8686). If PERMANENT FAULT, SIGNAL TOO HIGH is displayed, go to next step. If PERMANENT FAULT, SIGNAL TOO LOW is displayed, go to step 3). If INTERMITTENT FAULT, SIGNAL TOO HIGH is displayed, go to step 8). If INTERMITTENT FAULT, SIGNAL TOO LOW is displayed, go to step 9).

2) If PERMANENT FAULT, SIGNAL TOO HIGH is displayed, turn ignition off. Disconnect front HO2S Black connector and/or rear HO2S Gray connector. Turn ignition on. Connect voltmeter between HO2S connector terminal No. 2 and ground. If voltmeter reads about zero volts, retest using new HO2S. If voltmeter does not read about zero volts, check wiring between HO2S connector terminal No. 2 and ECM terminal A14 (Code 5-2-1) or terminal A29 (Code 5-2-2) for signs of a short circuit to voltage.

3) If PERMANENT FAULT, SIGNAL TOO LOW is displayed, turn ignition off. Disconnect front HO2S Black connector and/or rear HO2S Gray connector. Turn ignition on. Connect voltmeter between HO2S connector terminal No. 1 and ground. If voltmeter reads battery voltage, go to next step. If voltmeter does not read battery voltage, check wiring between HO2S connector terminal No. 1 and main relay connector terminal No. 3 for an open circuit.

4) Turn ignition on. Disconnect HO2S connector. Connect voltmeter between HO2S connector terminal No. 2 and ground. If voltmeter reads about zero volts, go to next step. If voltmeter does not read about zero volts, check wiring between HO2S connector terminal No. 2 and ECM terminal A14 (Code 5-2-1) or terminal A29 (Code 5-2-2) for a short circuit to voltage.

5) Turn ignition off. Wait about 2 minutes. Disconnect HO2S connector. Disconnect ECM. Connect ohmmeter between HO2S connector terminal No. 2 and ground. If ohmmeter reads infinite resistance, go to next step. If ohmmeter does not read infinite resistance, check wiring between HO2S connector terminal No. 2 and ECM terminal A14 (Code 5-2-1) or terminal A29 (Code 5-2-2) for a short circuit to ground.

6) Turn ignition off. Disconnect HO2S and ECM connectors. Connect Breakout Box (981-3190) to ECM connector. Check all grounds. See COMPUTERIZED ENGINE CONTROLS in I - SYSTEM/COMPONENT TESTS article. Connect an ohmmeter between HO2S connector terminal No. 2 and breakout box pin No. 14 (Code 5-2-1) or pin No. 29 (Code 5-2-2). If ohmmeter reads about zero ohms, go to next step. If ohmmeter does not read about zero ohms, check wiring between HO2S connector terminal No. 2 and ECM terminal A14 (Code 5-2-1) or terminal A29 (Code 5-2-2) for an open circuit.

7) Turn ignition off. Reconnect HO2S connector. Disconnect ECM connector. Connect ohmmeter between breakout box pins No. 27 and No. 14 (Code 5-2-1) or No. 29 (Code 5-2-2). If ohmmeter reads 1.5-13 ohms, code is caused by poor contact in ECM and/or HO2S connector. If ohmmeter does not read 1.5-13 ohms, retest using new HO2S.

8) If INTERMITTENT FAULT, SIGNAL TOO HIGH is displayed, check wiring between HO2S connector terminal No. 2 and ECM terminal A14 (Code 5-2-1) or terminal A29 (Code 5-2-2) for an intermittent short circuit to voltage.

9) If INTERMITTENT FAULT, SIGNAL TOO LOW is displayed, check wiring between HO2S connector terminal No. 1 and main relay connector terminal No. 3 for an intermittent open circuit. Check wiring between

HO2S connector terminal No. 2 and ECM terminal A14 (Code 5-2-1) or terminal A29 (Code 5-2-2) for an intermittent open circuit or short circuit to ground. Also check HO2S and ECM connectors for loose connection, contact resistance, and oxidation.

Code 5-3-1 (Power Stage Group "A")

1) Check for other codes. If one or more of Codes 1-1-5, 1-2-5, 1-3-5, 1-4-5, or 1-5-5 are stored, perform testing for that code first. If Code 5-4-1 is stored, perform testing for this code second. If no other codes are stored, go to next step.

2) Using Volvo Scan Tool (998-8686) set to Diagnostic Test Mode (DTM) No. 3, check that injectors operate properly. For DTM No. 3 to operate correctly, 3 injectors must be disconnected. Test must be performed several times with different injectors. If injectors function, go to step 8). If injectors do not function, go to next step.

3) Turn ignition off. Disconnect suspect injector. Turn ignition on. Connect voltmeter between injector connector terminal No. 1 and ground. If voltmeter reads battery voltage, go to next step. If voltmeter does not read battery voltage, check wiring between main relay connector terminal No. 3 and injector connector terminal No. 1 for an open circuit.

4) Turn ignition off. Disconnect suspect injector connector. Connect ohmmeter between injector connector terminals No. 1 and 2. If ohmmeter reads about 14.5 ohms, go to next step. If ohmmeter does not read 14.5 ohms, retest using new injector.

5) Turn ignition on. Disconnect suspect injector connector. Connect voltmeter between injector connector terminal No. 2 and ground. If voltmeter reads about zero volts, go to next step. If voltmeter does not read about zero volts, check wiring between injector connector terminal No. 2 and ECM terminals A10, A38, A24, A23 or A9 (depending on which injector is inoperative) for a short circuit to voltage.

6) Turn ignition off. Wait about 2 minutes. Disconnect suspect injector connector. Connect ohmmeter between injector connector terminal No. 2 and ground. If ohmmeter reads 25-40 k/ohms, source of code is poor contact in injector connector. Repair as necessary. If ohmmeter reads infinite resistance, go to next step. If ohmmeter reads about zero ohms, check wiring between injector connector terminal No. 2 and ECM terminal A10, A38, A24, A23 or A9 (depending on which injector does not work) for a short circuit to ground.

7) Turn ignition off. Disconnect suspect injector connector. Ensure ECM connector terminals are clean and tight. Repair as necessary. Connect an ohmmeter between injector connector terminal No. 2 and ground. If ohmmeter reads 25-40 k/ohms, code is caused by poor contact at ECM connector. If ohmmeter does not read 25-40 k/ohms, check wiring between injector connector terminal No. 2 and ECM terminal A10, A38, A24, A23 or A9 for an open circuit.

8) Using Volvo Scan Tool (998-8686) and Diagnostic Test Mode (DTM) No. 3, verify EVAP valve is operating correctly. If EVAP is okay, fault is intermittent. Go to step 14). If EVAP is not okay, go to next step.

9) Remove EVAP valve from bracket. Remove sound insulation from valve. Turn ignition off. Disconnect EVAP valve. Turn ignition on. Connect voltmeter between EVAP valve connector terminal No. 1 and ground. If voltmeter reads battery voltage, go to next step. If voltmeter does not read battery voltage, check wiring between EVAP valve connector terminal No. 1 and main relay for an open circuit.

10) Turn ignition off. Disconnect EVAP valve. Connect ohmmeter between EVAP valve connector terminals No. 1 and 2. If ohmmeter reads about 26 ohms at 68°F, go to next step. If ohmmeter does not read about 26 ohms, retest using new EVAP valve.

11) Turn ignition on. Disconnect EVAP valve connector. Connect voltmeter between EVAP valve connector terminal No. 2 and ground. If voltmeter reads about zero volts, go to next step. If voltmeter does not read about zero volts, check wiring between EVAP valve connector terminal No. 2 and ECM terminal A39 for a short circuit to voltage.

12) Turn ignition off. Wait about 2 minutes. Disconnect EVAP valve connector. Connect an ohmmeter between EVAP valve connector terminal No. 2 and ground. If ohmmeter reads about 25-40 k/ohms, code is caused by poor terminal contact in EVAP valve connector. Repair as necessary. If ohmmeter reads infinite resistance, go to next step. If ohmmeter reads about zero ohms, check wiring between EVAP valve connector terminal No. 2 and ECM terminal A39 for a short circuit to ground.

13) Turn ignition off. Disconnect EVAP valve connector. Ensure ECM connector terminals are clean and tight. Repair as necessary. Connect ohmmeter between EVAP valve connector terminal No. 2 and ground. If ohmmeter reads 25-40 k/ohms, source of code was poor contact in ECM connector. If ohmmeter does not read 25-40 k/ohms, check wiring between EVAP valve connector terminal No. 2 and ECM terminal A39 for an open circuit.

14) If fault is intermittent, check wiring between main relay connector terminal No. 3 and injector connector terminal No. 1 for an intermittent open circuit. Check wires between injector connector terminal No. 2 and ECM terminals A10, A38, A24, A23 and A9 for an intermittent open circuit, short circuit to ground, or intermittent short circuit to voltage. Check wiring between main relay connector terminal No. 3 and EVAP valve connector terminal No. 1 for an intermittent open circuit. Check wiring between EVAP valve connector terminal No. 2 and ECM terminal A39 for an intermittent open circuit, short circuit to ground, or short circuit to voltage. Also check main relay, injector, EVAP valve and ECM connector for loose connection.

#### Code 5-3-2 (Power Stage Group 'B')

1) Check if other codes are present. If Codes 2-2-3, 2-4-5, 5-1-4, or 5-3-5 are stored, perform testing for these first. If no other codes are stored, go to next step.

2) Disconnect 3 injectors. Using Volvo Scan Tool (998-8686) set to Diagnostic Test Mode (DTM) No. 3, verify that IAC valve operates. If IAC valve functions, go to step 11). If IAC valve does not operate, go to next step.

3) Turn ignition off. Disconnect IAC valve. Turn ignition on. Connect voltmeter between IAC valve connector terminal No. 2 and ground. If battery voltage is present, go to next step. If battery voltage is not present, check wiring between IAC valve connector terminal No. 2 and main relay connector terminal No. 3 for an open circuit.

4) Turn ignition off. Disconnect IAC valve connector. Connect ohmmeter between IAC valve connector terminals No. 1 and 2. Read valve. Connect ohmmeter between IAC valve connector terminals No. 2 and 3. Read valve again. If ohmmeter reads 9-14 ohms in both cases, go to next step. If ohmmeter does not read 9-14 ohms in both cases, retest using new IAC valve.

5) Turn ignition on. Disconnect IAC valve connector. Connect voltmeter between IAC valve connector terminal No. 3 and ground. If voltmeter reads about zero ohms, go to next step. If voltmeter does not read about zero ohms, check wiring between IAC valve connector terminal No. 3 and ECM terminal A11 for a short circuit to voltage.

6) Turn ignition off. Wait about 2 minutes. Disconnect IAC valve connector. Connect ohmmeter between IAC valve connector terminal No. 3 and ground. If ohmmeter reads 10-20 k/ohms, go to step 8). If ohmmeter reads infinite resistance, go to next step. If ohmmeter reads about zero ohms, check wiring between IAC valve connector terminal No.

3 and ECM terminal A11 for a short circuit to ground.

7) Turn ignition off. Disconnect IAC valve connector. Ensure terminals are clean and tight. Repair as necessary. Connect ohmmeter between IAC valve connector terminal No. 3 and ground. If ohmmeter reads 10-20 k/ohms, code is caused by poor terminal contact. If ohmmeter does not read 10-20 k/ohms, check wiring between IAC valve connector terminal No. 3 and ECM terminal A11 for an open circuit.

8) Turn ignition on. Disconnect IAC valve connector. Connect voltmeter between IAC valve connector terminal No. 1 and ground. If voltmeter reads about zero volts, go to next step. If voltmeter does not read about zero volts, check wiring between IAC valve connector terminal No. 1 and ECM terminal A25 for a short circuit to voltage.

9) Turn ignition off. Wait about 2 minutes. Disconnect IAC valve connector. Connect ohmmeter between IAC valve connector terminal No. 1 and ground. If ohmmeter reads about 10-20 k/ohms, code is caused by poor contact in IAC valve connector. Repair as necessary. If ohmmeter reads infinite resistance, go to next step. If ohmmeter reads about zero ohms, check wiring between IAC valve connector terminal No. 1 and ECM terminal No. 5 for a short circuit to ground.

10) Turn ignition off. Disconnect IAC valve connector. Check ECM connector terminals for oxidation or poor contact. Repair as necessary. Reconnect ECM connector. Connect ohmmeter between IAC valve connector terminal No. 1 and ground. If ohmmeter reads 10-20 k/ohms, code was caused by poor contact in ECM connector. If ohmmeter does not read 10-20 k/ohms, check wiring between IAC valve connector terminal No. 1 and ECM terminal A25 for an open circuit.

11) Using Volvo Scan Tool (998-8686), enter Diagnostic Test Mode (DTM) No. 3 and verify engine cooling fan functions. If cooling fan operates on turbo vehicles, go to step 18). If cooling fan operates on non-turbo vehicles, go to step 24). If cooling fan does not operate at all, go to next step.

12) Turn ignition off. Disconnect Fan Control (FC) relay connector terminal "A". Turn ignition on. Connect voltmeter between FC relay connector terminal "A" and ground. If battery voltage is present, go to next step. If battery voltage is not present, check fusible link between starter motor and FC relay. If there is an open circuit in fusible link, probable cause is a short circuit to ground in the wiring.

13) Turn ignition off. Disconnect FC relay connector terminal "A". Connect an ohmmeter between FC relay connector terminals A1 and B1. If ohmmeter reads about 80 ohms, go to next step. If ohmmeter does not read about 80 ohms, retest using new FC relay.

14) Turn ignition on. Disconnect FC relay connector "B". Connect voltmeter between FC relay connector "B", terminal No. 1, and ground. If voltmeter reads about zero ohms, go to next step. If voltmeter does not read about zero ohms, check wiring between FC relay connector terminal B1 and ECM terminal A7 for a short circuit to voltage.

15) Turn ignition off. Wait about 2 minutes. Disconnect FC connector "B". Connect an ohmmeter between FC relay connector "B", terminal No. 1, and ground. If ohmmeter reads 28-38 k/ohms, go to step 17). If ohmmeter reads infinite resistance, go to next step. If ohmmeter reads about zero ohms, check wiring between FC relay connector B1 and ECM terminal A7 for a short to ground.

16) Turn ignition off. Disconnect FC relay connector "B". Disconnect ECM and clean terminals of oxidation. Reconnect ECM. Connect ohmmeter between FC relay connector "B", terminal No. 1, and ground. If ohmmeter reads 28-38 k/ohms, code was caused by poor contact at ECM connector. If ohmmeter does not read 28-38 k/ohms, check wiring between FC relay connector B1 and ECM terminal A7 for an open circuit.

17) Turn ignition off. Disconnect FC relay connector terminal "B". Connect ohmmeter between FC relay connector "B", terminal No. 2,



and ground. If ohmmeter reads infinite resistance, code was caused by poor contact in FC relay connector. If ohmmeter reads about zero ohms, check wiring between FC relay connector B2 and ECM terminal A22 for a short circuit to ground.

18) Using Volvo Scan Tool (998-8686) set to Diagnostic Test Mode (DTM) No. 3, verify if TC control valve is functioning. If TC control valve functions, go to step 24). If TC control valve does not function, go to next step.

19) Turn ignition off. Disconnect TC control valve. Turn ignition on. Connect voltmeter between TC control valve connector terminal No. 1 and ground. If voltmeter reads battery voltage, go to next step. If voltmeter does not read battery voltage, check wiring between TC control valve connector terminal No. 1 and main relay connector for an open circuit.

20) Turn ignition off. Disconnect TC control valve. Connect ohmmeter between connector terminals No. 1 and 2. If ohmmeter reads 22-26 ohms, go to next step. If ohmmeter does not read 22-26 ohms, retest using new TC control valve.

21) Turn ignition on. Disconnect TC control valve connector. Connect voltmeter between TC control valve connector terminal No. 2 and ground. If voltmeter reads about zero volts, go to next step. If voltmeter does not read about zero volts, check wiring between TC control valve connector terminal No. 2 and ECM terminal B41 for a short circuit to voltage.

22) Turn ignition off. Wait about 2 minutes. Disconnect IAC valve connector. Connect an ohmmeter between TC control valve connector terminal No. 2 and ground. If ohmmeter reads 27-37 k/ohms, code is caused by poor contact in TC control valve connector. Repair as necessary. If ohmmeter reads infinite resistance, go to next step. If ohmmeter reads about zero ohms, check wiring between TC control valve connector terminal No. 2 and ECM terminal B41 for a short circuit to ground.

23) Turn ignition off. Disconnect TC control valve connector. Disconnect ECM connector and ensure contacts are clean and tight. Repair as necessary. Reconnect ECM connector. Connect an ohmmeter between TC control valve connector terminal No. 2 and ground. If ohmmeter reads 27-37 k/ohms, code was caused by poor contact in ECM connector. If ohmmeter does not read 27-37 k/ohms, check wiring between TC control valve connector terminal No. 2 and ECM terminal B41 for an open circuit.

24) If intermittent fault is suspected, check main relay, IAC valve, FC relay, TC valve, and related wiring for open or short circuits to ground or voltage. Repair as necessary.

#### Code 5-3-3 (Power Stage Group ''C'')

1) Turn ignition off. Disconnect connector "B" from FC relay. Turn ignition on. Connect voltmeter between FC relay connector "B", terminal No. 2, and ground. If voltmeter reads 0-1 volt, go to next step. If voltmeter does not read 0-1 volt, check wiring between FC relay connector B2 and ECM terminal A22 for a short circuit to voltage.

2) Turn ignition off. Disconnect FC relay connector "B". Connect ohmmeter between FC relay connector "A", terminal No. 1, and connector "B", terminal No. 2. If ohmmeter reads about 80 ohms, and vehicle is equipped with EGR, go to next step. If ohmmeter reads about 80 ohms and vehicle is not equipped with EGR, go to step 5). If ohmmeter does not read about 80 ohms, retest using new FC relay.

3) Turn ignition off. Disconnect EGR controller. Turn ignition on. Connect voltmeter between EGR controller connector terminal No. 2 and ground. If voltmeter reads 0-1 volt, go to next step. If voltmeter does not read 0-1 volt, check wiring between EGR controller connector terminal No. 2 and ECM terminal A40 for a short to voltage.

4) Turn ignition off. Disconnect EGR controller connector. Connect ohmmeter between EGR controller connector terminals No. 1 and 2. If ohmmeter reads 75-95 ohms, go to next step. If ohmmeter does not read 75-95 ohms, retest using new EGR controller.

5) Start and run engine at idle. Connect breakout box to ECM. Connect voltmeter between breakout box pins No. 21 and 28. If voltmeter reads 6-7 volts and vehicle is equipped with automatic transmission, go to next step. If voltmeter reads 6-7 volts and vehicle is equipped with manual transmission, go to step 7). If voltmeter does not read 6-7 volts, check wiring between instrument cluster connector terminal A11 and ECM terminal B21 for a short circuit to voltage.

6) Connect breakout box and check all ground connections. See COMPUTERIZED ENGINE CONTROLS in I - SYSTEM/COMPONENT TESTS article. Ensure ECM is connected. Turn ignition on. Connect voltmeter between breakout box pins No. 12 and 28. If voltmeter reads 0-1 volt, go to next step. If voltmeter does not read 0-1 volt, check wiring between ECM terminal B12 and TCM terminal B12 for a short circuit to voltage.

7) Turn ignition on. Connect voltmeter between breakout box pins No. 23 and 28. If voltmeter reads 4-8 volts, and vehicle is equipped with trip computer, go to next step. If voltmeter reads 4-8 volts and vehicle is not equipped with trip computer, go to step 9). If voltmeter does not read 4-8 volts, check wiring between instrument cluster connector terminal A26 and ECM terminal B23 for a short circuit to voltage. On vehicles equipped with Electronic Climate Control (ECC), also check wiring between ECM terminal B23 and ECC control module terminal A23 for a short circuit to voltage. ECC control module is located behind A/C controls on dash.

8) Turn ignition on. Connect voltmeter between breakout box pins No. 39 and 28. If voltmeter reads 0-1 volt, fault is intermittent. Go to next step. If voltmeter does not read 0-1 volt, check wiring between instrument cluster connector terminal A9 and ECM terminal B39 for a short circuit to voltage.

9) If fault is suspected to be intermittent, check wiring between FC relay connector terminal B2 and ECM terminal A22 for an intermittent short circuit to voltage. Check wiring between EGR controller connector terminal No. 2 and ECM terminal A40 for an intermittent short circuit to voltage. Check wiring between instrument cluster connector terminal A11 and ECM terminal B21 for an intermittent short circuit to voltage. Check wiring between ECM terminal B12 and TCM terminal B12 for an intermittent short circuit to voltage. Check wiring between instrument cluster terminal A26 and ECM terminal B23 for an intermittent short circuit to voltage. Check wiring between instrument cluster connector terminal A9 and ECM terminal B39 for an intermittent short circuit to voltage. On vehicles with ECC, also check wiring between ECM terminal B23 and ECC control module terminal A23 for an intermittent short circuit to voltage. ECC control module is located behind A/C controls on dash.

#### Code 5-3-3 (Power Stage Group "C")

1) Turn ignition off. Disconnect FC relay connector "B". Turn ignition on. Connect voltmeter between FC relay connector "B", terminal No. 2, and ground. If voltmeter reads 0-1 volt, go to next step. If voltmeter does not read 0-1 volt, check wiring between FC relay connector "B", terminal No. 2, and ECM terminal A22 for short circuit to voltage.

2) Turn ignition off. Disconnect FC relay connectors "B" and "A". Connect ohmmeter between FC relay connector "B", terminal No. 2, and connector "A", terminal No. 1. If ohmmeter reads about 80 ohms and vehicle is equipped with EGR, go to next step. If ohmmeter reads about 80 ohms and vehicle is not equipped with EGR, go to step 5). If ohmmeter does not read about 80 ohms, retest using new FC relay.

3) Turn ignition off. Disconnect EGR controller. Turn

ignition on. Connect voltmeter between EGR controller connector terminal No. 2 and ground. If voltmeter reads 0-1 volt, go to next step. If voltmeter does not read 0-1 volt, check wiring between EGR controller connector terminal No. 2 and ECM terminal A40 for a short circuit to voltage.

4) Turn ignition off. Disconnect EGR controller. Connect ohmmeter between EGR controller connector terminals No. 1 and 2. If ohmmeter reads 75-95 ohms, go to next step. If ohmmeter does not read 75-95 ohms, retest using new EGR controller.

5) Start and run engine at idle. Connect breakout box to ECM. Connect voltmeter between breakout box pins No. 21 and 28. If voltmeter reads 6-7 volts, and vehicle is equipped with automatic transmission, go to next step. If voltmeter reads 6-7 volts and vehicle is equipped with manual transmission, go to step 7). If voltmeter does not read 6-7 volts, check wiring between instrument cluster connector terminal A11 and ECM terminal B21 for a short circuit to voltage.

6) Turn ignition off. Connect breakout box to ECM. Check ground connections. See COMPUTERIZED ENGINE CONTROLS in the I - SYSTEM/COMPONENT TESTS article. Connect ECM to breakout box. Turn ignition on. Connect voltmeter between breakout box pins No. 12 and 28. If voltmeter reads 0-1 volt, go to next step. If voltmeter does not read 0-1 volt, check wiring between ECM terminal B12 and TCM terminal B12 for a short circuit to voltage.

7) Turn ignition on. Connect voltmeter between breakout box pins No. 23 and 28. If voltmeter reads 4-8 volts and vehicle is equipped with trip computer, go to next step. If voltmeter reads 4-8 volts and vehicle is not equipped with trip computer, go to step 9). If voltmeter does not read 4-8 volts, check wiring between instrument cluster connector terminal A26 and ECM terminal B23 for a short circuit to voltage. If vehicle is equipped with Electronic Climate Control (ECC), also check wiring between ECM terminal B23 and ECC control module terminal A23 for a short circuit to voltage. ECC control module is located behind A/C controls on dash.

8) Turn ignition on. Connect voltmeter between breakout box pins No. 39 and 28. If voltmeter reads 0-1 volt, go to next step. If voltmeter does not read 0-1 volt, check wiring between instrument cluster connector terminal A9 and ECM terminal B39 for a short circuit to voltage.

9) Fault is intermittent. Check wiring between FC relay and ECM, between EGR controller and ECM, between instrument cluster and ECM, and between ECM and TCM for an intermittent short circuit to voltage. On vehicles with ECC, check wiring between ECM and ECC module for an intermittent short circuit to voltage.

#### Code 5-3-4 (Power Stage Group "D")

1) Attempt to start engine. If engine starts, go to next step. If engine does not start, go to step 5).

2) Connect breakout box and check ground connections. See COMPUTERIZED ENGINE CONTROLS in I - SYSTEM/COMPONENT TESTS article. Connect ECM to breakout box. Turn ignition on. Connect voltmeter between breakout box pins No. 7 and 28. If voltmeter reads 0-2 volts, and vehicle is equipped with A/C, go to next step. If voltmeter reads 0-2 volts, and vehicle is not equipped with A/C, go to step 8). If voltmeter does not read 0-2 volts, check wiring between instrument cluster connector terminal B11 and ECM terminal B7 for a short circuit to voltage.

3) Turn A/C on. Set blower at low speed. Start engine and run at idle. Connect voltmeter between breakout box pins No. 40 and 28. If voltmeter reads 0-2 volts, go to step 8). If voltmeter does not read 0-2 volts, go to next step.

4) Turn ignition off. Disconnect A/C relay. Turn A/C on. Set blower at low speed. Start engine and run at idle. Connect voltmeter

between breakout box pins No. 40 and 28. If voltmeter reads 0-2 volts, retest using new A/C relay. If voltmeter does not read 0-2 volts, check wiring between A/C relay connector terminal No. 4 and Electronic Climate Control (ECC) control module terminal A25 for a short circuit to voltage. ECC control module is located behind A/C controls on dash.

5) Check ground connections with breakout box. See COMPUTERIZED ENGINE CONTROLS in I - SYSTEM/COMPONENT TESTS article. Connect ECM. Turn ignition on. Connect voltmeter between breakout box pins No. 27 and 28. If voltmeter reads about one volt, go to step 7). If voltmeter does not read about one volt, go to next step.

6) Turn ignition off. Disconnect fuel pump relay. Turn ignition on. Connect voltmeter between breakout box pins No. 27 and 28. If voltmeter reads about one volt, retest using new fuel pump relay. If voltmeter does not read about one volt, check wiring between fuel pump relay connector terminal No. 4 and ECM terminal B27 for a short circuit to voltage.

7) Turn ignition off. Disconnect ignition power stage. Turn ignition on. Connect voltmeter between breakout box pins No. 11 and 28. If voltmeter reads 0-1 volt, retest using new power stage. If voltmeter does not read 0-1 volt, check wiring between ignition power stage connector terminal No. 4 and ECM terminal B11 for a short circuit to voltage.

8) Problem is intermittent. Check wiring between instrument cluster connector terminal B11 and ECM terminal B7, and wiring between A/C relay connector terminal No. 4 and ECM terminal B40 for an intermittent short circuit to voltage. If vehicle is equipped with ECC, check wiring between A/C relay connector terminal No. 4 and ECC control module terminal A25, wiring between fuel pump relay connector terminal No. 4 and ECM terminal B27, and wiring between ignition power stage connector terminal No. 4 and ECM terminal B11 for an intermittent short circuit to voltage.

#### Code 5-3-5 (Turbocharger Control Valve Signal)

1) Check status message on Volvo Scan Tool (998-8686). To obtain correct status message, it may be necessary to floor accelerator quickly a couple of times. If fault is PERMANENT, SIGNAL TOO HIGH, go to step 2). If fault is PERMANENT, SIGNAL TOO LOW, go to step 3). If fault is INTERMITTENT, SIGNAL TOO HIGH, go to step 7). If fault is INTERMITTENT, SIGNAL TOO LOW, go to step 8).

2) Turn ignition off. Disconnect Turbocharger (TC) control valve. Turn ignition on. Connect voltmeter between TC control valve connector terminal No. 2 and ground. If voltmeter reads less than one volt, retest using new TC control valve. If voltmeter does not read less than one volt, check wiring between TC control valve connector terminal No. 2 and ECM terminal B41 for a short circuit to voltage.

3) Turn ignition off. Disconnect TC control valve. Turn ignition on. Connect voltmeter between TC control valve connector terminal No. 1 and ground. If voltmeter reads battery voltage, go to next step. If voltmeter does not read battery voltage, check wiring between main relay connector terminal No. 3 and TC control valve connector terminal No. 1 for an open circuit.

4) Turn ignition off. Wait about 2 minutes. Disconnect TC control valve. Connect ohmmeter between TC control valve connector terminal No. 2 and ground. If ohmmeter reads 27-37 k/ohms, go to step 6). If ohmmeter reads about zero volts, check wiring between TC control valve connector terminal No. 2 and ECM terminal B41 for a short circuit to ground. If ohmmeter reads infinite resistance, go to next step.

5) Turn ignition off. Disconnect TC control valve. Disconnect ECM connector. Ensure ECM connector terminals are clean and tight. Repair as necessary. Reconnect ECM connector. Connect ohmmeter between TC control valve connector terminal No. 2 and ground. If ohmmeter reads 27-37 k/ohms, problem is poor contact at ECM connector. If

ohmmeter does not read 27-37 ohms, check wiring between TC control valve connector terminal No. 2 and ECM terminal B41 for an open circuit.

6) Turn ignition off. Reconnect TC control valve. Turn ignition on. Erase code. Start engine. Floor accelerator a couple of times. If fault remains, code will return within one minute. If code returns, retest using new TC control valve. If code does not return, code is caused by poor contact in TC control valve connector. Repair as necessary.

7) Check TC control valve and ECM connectors for loose connection or contact resistance. Also check wiring between TC control valve connector terminal No. 2 and ECM terminal B41 for an intermittent short circuit to voltage.

8) Check TC control valve and ECM connectors for loose connection or contact resistance. Check wiring between TC control valve connector terminal No. 2 and ECM terminal B41 for an intermittent open circuit or short circuit to ground. Also check wiring between TC control valve connector terminal No. 1 and main relay connector terminal No. 3 for an intermittent open circuit.

#### Code 5-4-1 (EVAP Signal)

1) Check status message on Volvo Scan Tool (998-8686). If fault is permanent and signal is too high, go to step 2). If fault is PERMANENT, SIGNAL TOO LOW, go to step 3). If fault is INTERMITTENT, SIGNAL TOO HIGH, go to step 7). If fault is INTERMITTENT, SIGNAL TOO LOW, go to step 8).

2) Turn ignition off. Disconnect EVAP valve. Connect ohmmeter between EVAP valve connector terminals No. 1 and 2. If ohmmeter reads about 26 ohms, check wiring between EVAP valve connector terminal No. 2 and ECM terminal A39 for a short circuit to voltage. If ohmmeter does not read 26 ohms, retest using new EVAP valve.

3) Turn ignition off. Disconnect EVAP valve. Turn ignition on. Connect voltmeter between EVAP valve connector, terminal No. 1, and ground. If voltmeter reads battery voltage, go to next step. If voltmeter does not read battery voltage, check wiring between EVAP valve connector terminal No. 1 and main relay connector terminal No. 3 for an open circuit.

4) Turn ignition off. Wait about 2 seconds. Disconnect EVAP valve. Connect ohmmeter between EVAP valve connector terminal No. 2 and ground. If ohmmeter reads 25-40 k/ohms, go to next step. If ohmmeter reads infinite resistance, go to step 6). If ohmmeter reads about zero ohms, check wiring between EVAP valve connector terminal No. 2 and ECM terminal A39 for a short circuit to ground.

5) Turn ignition off. Disconnect EVAP valve connector. Connect ohmmeter between EVAP valve connector terminals No. 1 and 2. If ohmmeter reads about 26 ohms, code is caused by poor contact in EVAP and/or ECM connector. Repair as necessary. If ohmmeter does not read about 26 ohms, retest using new EVAP valve.

6) Turn ignition off. Disconnect EVAP valve connector. Disconnect ECM. Ensure ECM connector terminals are clean and make good terminal contact. Repair as necessary. Connect ohmmeter between EVAP valve connector terminal No. 2 and ground. If ohmmeter reads 25-40 k/ohms, code is caused by poor contact at ECM connector. If ohmmeter does not read 25-40 k/ohms, check wiring between EVAP valve connector terminal No. 2 and ECM terminal A39 for an open circuit.

7) If fault is intermittent and signal is too high, check wiring between EVAP valve connector terminal No. 2 and ECM terminal A39 for an intermittent short circuit to voltage. Repair as necessary.

8) If fault is intermittent and signal is too low, check EVAP valve and ECM connector for loose connection or contact resistance. Check wiring between EVAP valve connector terminal No. 1 and main relay connector terminal No. 3 for an intermittent open circuit. Also check wiring between EVAP valve connector terminal No. 2 and ECM

terminal A39 for an intermittent open circuit or short circuit to ground.